

## MEMORANDUM OF UNDERSTANDING

### BETWEEN

**THE CITY AND COUNTY OF SAN FRANCISCO, ACTING BY AND THROUGH  
THE DEPARTMENT OF PUBLIC HEALTH AND  
THE MAYOR'S OFFICE OF HOUSING AND COMMUNITY DEVELOPMENT  
and  
MERCY HOUSING CALIFORNIA**

This Memorandum of Understanding (this “**MOU**”) is entered into this \_\_\_\_\_, 2026 (the “**Effective Date**”), by and between the City and County of San Francisco (“**City**”), acting by and through the Department of Public Health (“**DPH**”) and the Mayor’s Office of Housing and Community Development (“**MOHCD**”), and Mercy Housing California, a California nonprofit public benefit corporation (“**Developer**”). DPH, MOHCD and Developer are collectively referred to herein as the (“**Parties**”).

### RECITALS

A. As San Francisco public health and housing agencies, DPH and MOHCD are committed to increasing the supply of affordable housing, supportive services and health services to support the housing stability, health and wellbeing of San Francisco’s most vulnerable populations.

B. The Laguna Honda Hospital and Rehabilitation Center (“**LHH**”) is under the jurisdiction of DPH and the San Francisco Health Commission. LHH is one of the nation’s largest skilled nursing facilities and has continuously provided long term care to San Francisco residents for over 150 years. The facility currently offers long-term and short-term skilled nursing services and acute rehabilitation services.

C. MOHCD administers a variety of financing programs to enable the development and preservation of affordable housing, including deeply affordable housing with supportive services. MOHCD guides and coordinates the City’s housing policy and monitors the long-term affordability and physical viability of the City’s stock of affordable housing under MOHCD’s jurisdiction in accordance with federal and local requirements.

D. Developer is a non-profit housing developer that is one of California’s most experienced providers of service-enriched housing. To support San Francisco’s rapidly growing senior population, Developer was selected by MOHCD to develop high-quality affordable housing for low-income seniors, to provide resident access to enhanced services, and to develop new community daycare facilities for children and adults at the LHH campus.

E. In 2019 over 71% of San Francisco voters approved Proposition A, a \$600 million general obligation bond (the “**Bond**”) to finance the construction of affordable housing, with \$50 million set aside for the construction of senior housing on the LHH campus. MOHCD plans on

utilizing a portion of the Bond proceeds as one source of financing under this MOU, in addition to other City and third-party sources of funds.

F. As envisioned by former Supervisor Norman Yee, the housing would include assisted living, an adult day health center and early childhood education center with intergenerational programming. The proposed development would create opportunities for programmatic synergies between the programs of LHH and the new housing. Creating a continuum of senior residential care on the LHH campus would fulfill an original goal of Measure A passed in November 1999 to create senior housing on site as part of the rebuild of the hospital which was not built due to cost constraints.

G. The identified location for the affordable senior housing is the former Clarendon Hall site located just west of the hospital, located within the Ring Road that rounds the northern edge of the developed campus. This area is a vacant gravel lot of roughly 89,645 s.f., currently being used as surface parking (“Site”).

H. On November 18, 2019, MOHCD issued a Request for Qualifications for the development of new affordable senior housing at LHH and Developer was selected as the project sponsor and developer. In December 2020, the Citywide Affordable Housing Loan Committee recommended a \$3 million predevelopment loan to the Developer for the purpose of conducting due diligence, design, and other predevelopment activities. Developer has proposed the development and construction of a senior housing project as described in Section 2 of this MOU (“Project”).

I. On April 12, 2025, the Health Commission approved a resolution endorsing a draft non-binding term sheet for the purpose of developing and constructing the Senior Housing Project on the LHH campus. The Health Commission endorsed MOHCD and Developer to submit applications to the Planning Department related to the development of the Project, and requested that MOHCD and Developer provide monthly project updates to the Laguna Honda Hospital Joint Conference Committee (“JCC”) and additional updates to the full Health Commission until the Project construction begins or another cadence to be determined by the Health Commission as project activities progress. Anticipated financing was identified as low-income housing tax credits, tax exempt bonds, public and private partnerships, MOHCD loan, and other affordable housing financing.

J. Given the lack of funding for affordable assisted living and the lack of State financing available for affordable housing development in 2026, the Parties agreed to scale back the size of the project that was described in the term sheet to one phase of senior housing with enhanced services, and for MOHCD to pursue additional funding for the Project to maintain momentum and keep the Project moving forward.. This model has evolved from the original vision of including a component of affordable assisted living due to current infeasibility of financing affordable assisted living.

K. Based on the foregoing, the Parties desire to enter into this MOU to set forth the respective roles and responsibilities under the Term Sheet, delineate the terms and conditions under which DPH, MOHCD and Developer will work together to define and create the affordable housing parcel, advance design and secure entitlements, provide site control to Developer for

financing applications, and undertake other activities during the predevelopment period of the Project at the Site.

**NOW, THEREFORE**, the Parties agree and commit to the following principles, actions, and responsibilities:

**1. Term of the MOU.** This MOU shall commence on the Effective Date and shall expire the earlier of (i) four (4) years from the Effective Date or (ii) on the date the Parties, pursuant to Section 4(c) below, enter into a ground lease for development of the Site, unless the Parties mutually agree to extend the term (the “**Term**”).

**2. The Project.** The senior housing project shall be a multifamily residential building with 100% of the 158 units affordable and restricted to senior residents 62 years or older, onsite enhanced supportive services for senior residents, one onsite management staff unit, and a senior center and early childhood education center on the ground floor for the wider community (the “**Project**”). The units will range in affordability from serving senior residents with incomes ranging between 15% to 50% of median income published by MOHCD (“**AMI**”) (contingent on operating subsidy funding being available). The Project will also include open space and all other building and design elements required by the Planning Code.

**3. Unit Priorities and Set Asides.** The Parties share the goal of making 25% of the units available to residents referred from Laguna Honda Hospital and other DPH facilities, contingent on the Parties identifying operating funding to support these units. In addition, MOHCD has budgeted funding under the Senior Operating Subsidy (“**SOS**”) program to deepen affordability for 40% of the units to residents with incomes of either 15% or 25% of AMI. Furthermore, the Parties will work to leverage other rental and operating subsidies to the extent possible to make as many units as possible units as deeply affordable as possible.

**4. Project Schedule and Benchmarks.** The Parties have agreed to meet the milestones set forth in **Exhibit “B”** attached hereto (the “**Project Schedule and Benchmarks**”). The **Project Schedule and Benchmarks** may be amended from time to time, subject to written mutual consent of the Parties.

**5. Project Implementation.** The Parties desire to implement the objectives generally agreed upon in the Health Commission Resolution dated April 12, 2025, as further developed in this MOU. The Parties will collaborate on a development process that includes the following components:

**6. Subdivision and Jurisdictional Transfer.**

(a) **Subdivision.** The Parties have agreed that Developer, surveyor, and architects will prepare and review the proposed parcel and subdivision map with DPH, LHH, and MOHCD. Thereafter, Developer, surveyor and consultants will prepare the subdivision application and submit to Department of Public Works Subdivision and Mapping Division.

- (b) **Jurisdictional Transfer.** The Parties will take all steps necessary to ensure transfer of jurisdiction of the property from DPH to MOHCD, including facilitating approvals by the Health Commission and the Board of Supervisors. The jurisdictional transfer is anticipated to be considered by the Health Commission and the Board of Supervisors concurrently with approval of the subdivision to establish the Site as a parcel and will be contingent on successful progress on the Project, with the parcel to return to DPH jurisdiction if the closing on the construction loan for the Project has not closed by the end of the term of this MOU, unless extended by the Parties.

**7. Conduct Community Outreach.** The Parties recognize the importance of input from San Francisco residents in the planning of the Project. To promote community participation and to ensure openness and transparency in the development process, Developer and MOHCD have established a schedule of community meetings, which they may amend from time to time. Developer will establish regular methods for community information-sharing and receipt of community input.

**8. Update Regulators.** The Parties will provide periodic updates as necessary about the Project to the Health Commission, JCC, the members of the Board of Supervisors and other regulatory entities whose approval or authorization or actions are required to move the Project forward. The Parties will conduct bi-monthly or monthly meetings to coordinate development. The Parties will make regular updates to the Health Commission / JCC on the status of the Project as it is in development to ensure that the Commission remains updated on issues related to the Project and how it may impact the LHH campus, including during and through the end of construction as will be outlined in the ground lease.

**9. Planning and Federal Environmental Review.** The Developer will submit an entitlement application for review by the Planning Department. Developer and MOHCD will initiate federal environmental review if federal funds will be used for the Project. Nothing in this MOU commits, or shall be deemed to commit DPH or MOHCD, or any other public agency to approve or implement the Project.

**10. Set Financial Terms.** MOHCD and the Developer are responsible for funding the predevelopment, construction, and operation phases of the Project, including potential use of tax credit and tax-exempt bond financing.

**11. Determine Project Feasibility.** MOHCD and the Developer are responsible for determining the physical, political, economic, and financial feasibility of the Project within the context of affordable housing financing typical structures. Developer is responsible for applying for financing.

**12. Negotiate and draft transaction documents.** MOHCD is responsible for negotiating and drafting the City loan and ground lease documents required to finance, construct, and operate the Project, including, for example, a loan agreement, ground lease, declaration of restrictions, and deed of trust, among others.

**13. Subsequent documents** to be established include the following:

- 13.1** Creation of the parcel for the Project through a subdivision and **Parcel Map** as identified in Ex. A (“**Parcel**”).
- 13.2 Option to Ground Lease** between MOHCD and Developer’s affiliated limited partnership, for the purpose of applying for state funding.
- 13.3** MOHCD and Developer will execute a **Ground Lease** at construction loan closing
- 13.4 The Logistics Plan** will be updated and finalized prior to construction loan and ground lease closing to govern the construction staging and coordination between the Developer, General Contractor, MOHCD, and LHH.
- 13.5** The Parties will develop an **agreement** for the operations period which will outline roles, reporting, responsibilities and communication protocols, which will be referenced in the Ground Lease as an obligation. In addition, the parties will explore shared resources between the LHH and the Project.
- 13.6 Resident Selection Criteria and Marketing Plan** will be drafted by Developer and will meet fair housing law and financing requirements. If DPH and MOHCD obtain funding for DPH units, the Developer will work with DPH and MOH on incorporating marketing and referral practices for the DPH referral target population.

## **14. Roles and Responsibilities.**

### **14.1 DPH.**

(a) Assistance to MOHCD and Developer. DPH and LHH agree to work collaboratively with MOHCD and the Developer to develop the Project at the Site by facilitating the following:

(i) Bi-weekly or monthly development team meetings for the planning of the proposed Project;

(ii) DPH has the option of participating in the selection panels to select the childcare and senior center providers;

(iii) A DPH/LHH representative has the option of participating in MOHCD design review at each phase to provide feedback on design and potential impacts on LHH. DPH comments will be coordinated with MOHCD comments and will be provided in a timely manner.

(iv) Providing of data needed to develop thoughtful policies and procedures for the senior housing including creating synergies between the housing and LHH, as well as to continue to provide necessary data during the operations of the Project, as needed;

(v) Providing of access to the Site for any necessary testing or due diligence prior to execution of the ground lease;

(vi) Facilitating the discussion of the jurisdictional transfer of the Site and, if approved, work with MOHCD to complete the jurisdictional transfer;

(vii) Collaborating with MOHCD on identification of operating subsidy for the DPH referral units and coordinate with Developer to create the marketing and referral process regarding initial and ongoing releasing of these units;

(viii) Collaborating with MOHCD and Developer on issues related to shared resources such as resident transportation, shared roadway maintenance, parking enforcement, utilities as applicable, and other areas of shared usage or collaboration as they arise; and

(ix) Collaborating with MOHCD and Developer during construction, as will be required by the ground lease and any related documents, including identification of any issues that present challenges to the ongoing operations at LHH and related DPH facilities on campus.

(b) Technical Reports. DPH shall give MOHCD and Developer copies of any and all relevant third-party technical reports regarding the Site that are in DPH's possession.

(c) Cost of Staff time and Consultants. DPH shall pay the costs of its staff time and the costs of its consultants, including attorneys, for securing approvals from the Health Commission and Board of Supervisors.

(d) Assist with Negotiations. As needed, DPH will assist MOHCD in negotiating the business terms and conditions to be included in the necessary transaction documents for implementing the Project.

## **14.2. MOHCD.**

(a) Responsibilities. MOHCD agrees to the following:

(i) Oversee all predevelopment activities leading to completion of all required transaction documents, approval of the ground lease by the Board of Supervisors, the closing of escrow, and the commencement of construction;

(ii) Pay for its costs of negotiations of business terms and conditions, and the drafting and execution of the required transaction documents of the Project;

(iii) Collaborate with the Developer to determine the overall financial feasibility of the Project and develop a projected capital budget for the Project;

(iv) Determine the overall project timeline based on the Parties' mutually acceptable list of project milestones or benchmarks;

(v) Provide necessary oversight, as the lead agency, of the predevelopment, construction, and operation phases of the Project;

(vi) Collaborate on developing thoughtful policies and procedures for the senior housing in collaboration with DPH and Developer, including working with DPH on the operating subsidy for the DPH referral units and taking the necessary steps for the jurisdictional transfer if approved;

(vii) Oversee the Developer's selection process to select the childcare and senior center providers.

### **14.3. Developer.**

(a) Responsibilities. Developer agrees to the following:

(i) select the architect, general contractor ("**Contractor**"), engineer, construction manager, and any other necessary third-party consultants in connection with preparation of the Project;

(ii) obtain project approvals from the Planning Department, Department of Building Inspection, and any other City departments with jurisdiction over the Project;

(iii) coordinate approval of the plans and specs by MOHCD and DPH;

(iv) negotiate and enter into all necessary contracts with architect, general contractor, engineers, construction manager, and any other necessary third-party consultants in connection with preparation of the Plans and Specs;

(v) develop a budget for the development of the Project and present the budget for review to MOHCD at each development milestone (completion of schematics, design development, construction documents, final construction budget);

(vi) present updated total development cost budgets including the pre-selected general contractor's cost estimate at each development phase for MOHCD review. Design Development and subsequent cost estimates will be accompanied by value engineering and constructability comments;

(vii) apply for Project financing;

(viii) work with the architect to complete the Project in accordance with the objectives as to cost, time and quality, and provide sufficient personnel with authority to achieve such objectives;

(ix) make available to MOHCD copies of all contracts related to the Project;

(x) coordinate and oversee the selection of the day care, health service partners and Senior Center provider;

(xi) meet regularly with MOHCD and DPH to collaborate on the Project;

(xii) develop Master Logistics Plan with project stakeholders DPH & MOHCD (the "Logistics Plan") for the construction period with preliminary draft included as **Exhibit C**;

(xiii) provide periodic updates to the JCC and Health Commission as requested by DPH and MOHCD;

(xiv) draft the resident selection criteria and marketing plan, including working closely with DPH on the DPH referral population;

(xv) collaborate with DPH and MOHCD during construction, as will be required by the ground lease and any related documents, including to address any issues raised by DPH that present challenges to the ongoing operations at LHH and related DPH facilities on campus; and

(xvi) all other predevelopment activities required to develop the Project.

(xvii) Cause to be constructed as part of the Project construction improvements on the LHH parcel within the Construction Easement areas as identified on the Exhibit A Site Plan/Parcel Map. Construction Easement areas #2 and #3 will be included within the cost of the Project and not reimbursed by DPH as they are to mitigate circulation impacts due to the construction of the Project. The Construction Easement #1 is intended to include the planned LHH future scope of work of altering the loading dock curb for improved operations at LHH into the Project's scope of work for efficiency and timing.

**15. Access to the Site.** If requested, DPH will grant MOHCD, its agent or representative, Developer, and/or their employees, officers, members, managers, directors, agents, contractors, consultants, architects and engineers (collectively, "**Agents**") a license to enter on and access the Site for the purposes of this MOU. Such license will specify the terms and conditions of MOHCD's and its Agents' entry on and access to the Site (including insurance requirements and indemnification obligations).

## **16. Future Agreements for construction period.**

18.1. The parties agree that the **Construction Period Logistics Plan** related to the construction period will be updated by the parties and will be a condition of



the gap funding loan from MOHCD, attached as a Draft Logistics Plan attached as **Ex. C**.

18.2. With DPH approval, Mercy will conduct some landscaping improvements on the LHH property to address changes to the LHH site as a result of the Project and to make the development fit within existing infrastructure. Those areas are identified as Construction Easements on the attached Exhibit A (site plan).

18.3. If the Project is constructed but (a) the ground lease is terminated after all debt has been repaid, and (b) the Project stops serving low income households as required by the MOHCD Declaration of restrictions and any other affordable housing restrictions, DPH has the option to require MOHCD to use the Project for DPH uses or transfer the Project to DPH. Concurrently with preparation of the ground lease, MOHCD will prepare a transfer option agreement acceptable to DPH, and MOHCD and DPH will execute such transfer option agreement prior to construction loan closing.

18.4. Once the Project is completed, an annual report to the JCC will be provided summarizing the status of operations and collaboration with LHH.

**17. Notices.** Any notice given under this MOU from MOHCD to DPH or Developer or vice versa, must be in writing delivered in person; and by any of the Agents by commercial courier, or by registered, certified mail or express mail, return receipt requested, with postage prepaid, to the mailing addresses below. All notices under this MOU will be deemed given, received, made or communicated on the date personal receipt actually occurs or, if mailed, on the delivery date or attempted delivery date shown on the return receipt. Any mailing address or telephone or facsimile number may be changed at any time by giving written notice of the change in the manner provided above at least 10 days before the effective date of the change.

For the convenience of the parties, copies of notices may also be given by email to the email address given below, by facsimile to the telephone number listed below, or other numbers as may be provided from time to time, but email, telephonic or facsimile notice will not be binding on either party. The effective time of a notice will not be affected by the receipt of the original or facsimile copy of the notice.

DPH: Department of Public Health  
1145 Market Street  
San Francisco, CA 94102  
Attn: Director  
Telephone: 415-254-8739

Laguna Honda Hospital  
375 Laguna Honda Boulevard  
San Francisco, CA 94116  
Attn: Executive Project Manager  
Telephone: 628-754-2363

Mayor's Office of Housing and Community Development  
One Van Ness Avenue, Fifth Floor,  
San Francisco, CA 94103  
Attn: Director  
Telephone: 415-701-5515

Developer: Mercy Housing California  
1256 Market Street  
San Francisco, CA 94102  
Att: President  
Telephone: 415-355-7100

**18. DPH, MOHCD and Developer Requirements.** All applicable City, MOHCD, and DPH requirements regarding contracts and contract procurements, leasing, and provisions of services shall be made applicable on case-by-case basis to the selected developer and its assigns, representatives, and agents.

**1. Miscellaneous Provisions.**

**11.1. Amendments.** The parties reserve the right to amend this MOU by mutual consent. It is mutually understood and agreed that no amendment, modification, alteration or variation of the terms of this MOU shall be valid unless in writing and signed and acknowledged and approved by the parties. This MOU constitutes the entire agreement of the parties and no oral understandings or agreement not incorporated herein shall be binding on either party. This MOU supersedes prior written materials used by the Parties in negotiating this MOU.

**11.2. Severability.** Except as otherwise specifically provided in this MOU, a judgment or court order invalidating any provision of this MOU, or its application to any person, will not affect any other provision of this MOU or its application to any other entity or person or circumstance, and the remaining portions of this MOU will continue in full force and effect, unless enforcement of this MOU as invalidated would be unreasonable or grossly inequitable under all of the circumstances or would frustrate the purposes of this MOU.

**11.3. Time is of the Essence.** Time is of the essence of each provision of this MOU, including performance under the **Project Schedule and Benchmarks**.

**19. List of Exhibits.** The following exhibits are attached and by this reference incorporated into this mou as if fully set forth above:

- Exhibit “A” **Site Plan and Preliminary Parcel Map**
- Exhibit “B” **Draft Project Schedule and Benchmarks**
- Exhibit “C” **Draft Logistics Plan Sheet**

*[Signatures on the Next Page]*

IN WITNESS WHEREOF, the Parties hereto have executed this MOU as of the day, month, and year first above written

**MOHCD:**

**DPH**

**City and County of San Francisco, a municipal corporation, acting by and through the Mayor's Office of Housing and Community Development**

**City and County of San Francisco, a municipal corporation, acting by and through the Department of Public Health**

\_\_\_\_\_  
Daniel Adams  
Director

\_\_\_\_\_  
Daniel Tsai  
Director

**Approved as to form:**

**Approved as to form:**

David Chu  
City Attorney

David Chu  
City Attorney

By: \_\_\_\_\_  
Keith Nagayama  
Deputy City Attorney

By: \_\_\_\_\_  
Deputy City Attorney

**Developer**

Mercy Housing California, a nonprofit public benefit corporation

By: Mercy Housing California

By: \_\_\_\_\_  
Tiffany Bohee  
President

Exhibit "A"  
**Site Plan and Preliminary Parcel Map**

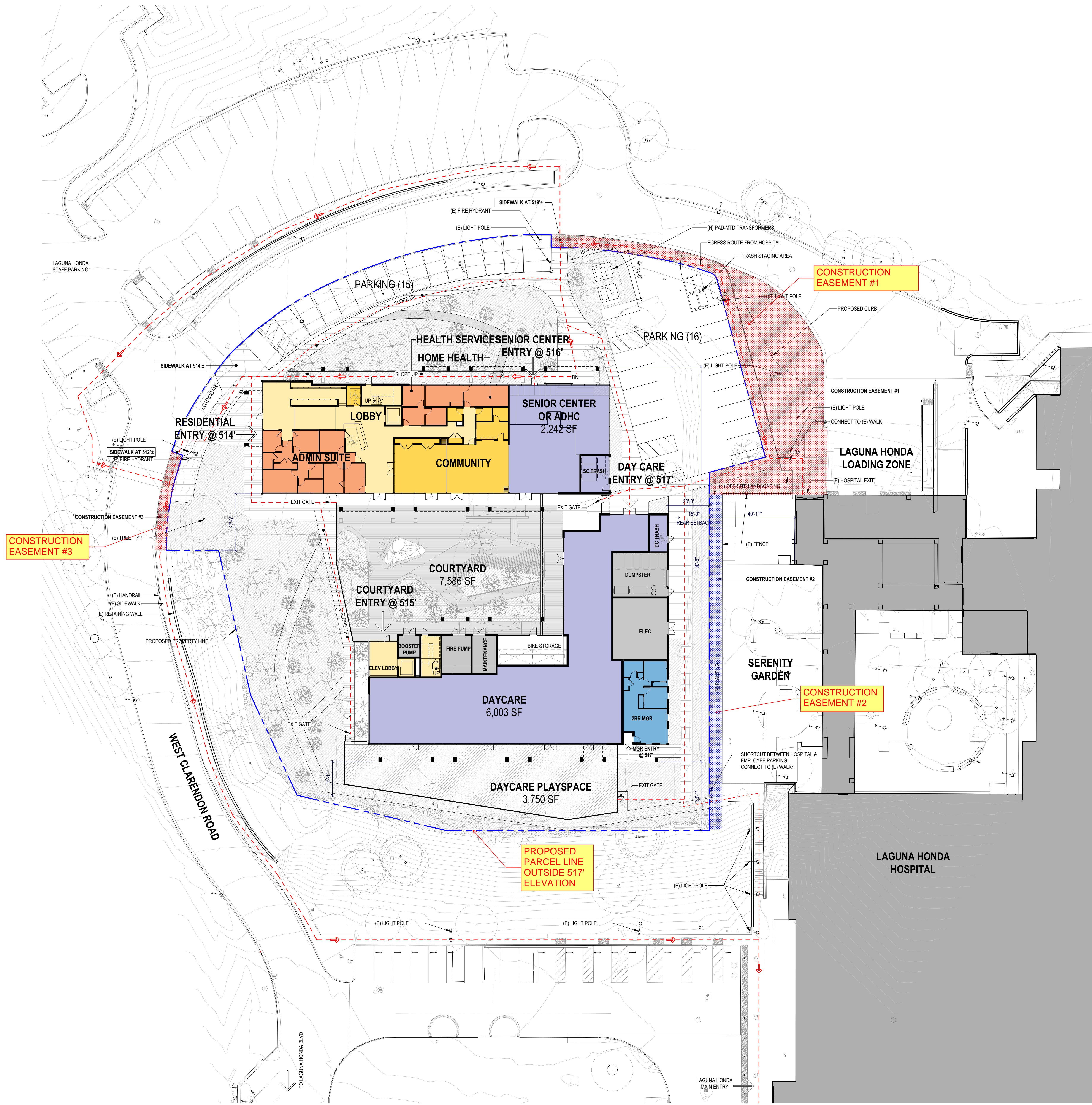

Written dimensions on these drawings shall have precedence over scaled dimensions. Contractors shall verify and be responsible for all dimensions and conditions on the job and this office must be notified of any variations from the dimensions and conditions shown by these drawings. Shop details must be submitted to this office for approval before proceeding with fabrication.

**PRINT IN COLOR: YES**

- General Notes/Legend/Key Plan:
- PROPERTY LINE
  - - - EGRESS PATH/ACCESSIBLE ROUTE OF TRAVEL
  - ⇒ EXIT
  - ▨ CONSTRUCTION EASEMENT

- PROGRAM KEY**
- 1BR
  - 2BR
  - CIRCULATION
  - ADMIN
  - COMMUNITY
  - DAY CARE / SENIOR CENTER
  - UTILITY

Consultant:

Stamp:

NO.	REVISION	DATE
	SB330 PRE-APP SUBMITTAL	10/10/2025
<b>DRAFT</b>		
03/02/2026 1:07:54 PM		

Project Number: 2012

Project Title:  
**LAGUNA HONDA SENIOR HOUSING**  
 375 LAGUNA HONDA BLVD,  
 SAN FRANCISCO, CA 94116

Sheet Title:  
**SITE PLAN**

Scale:  
 1" = 20'-0"

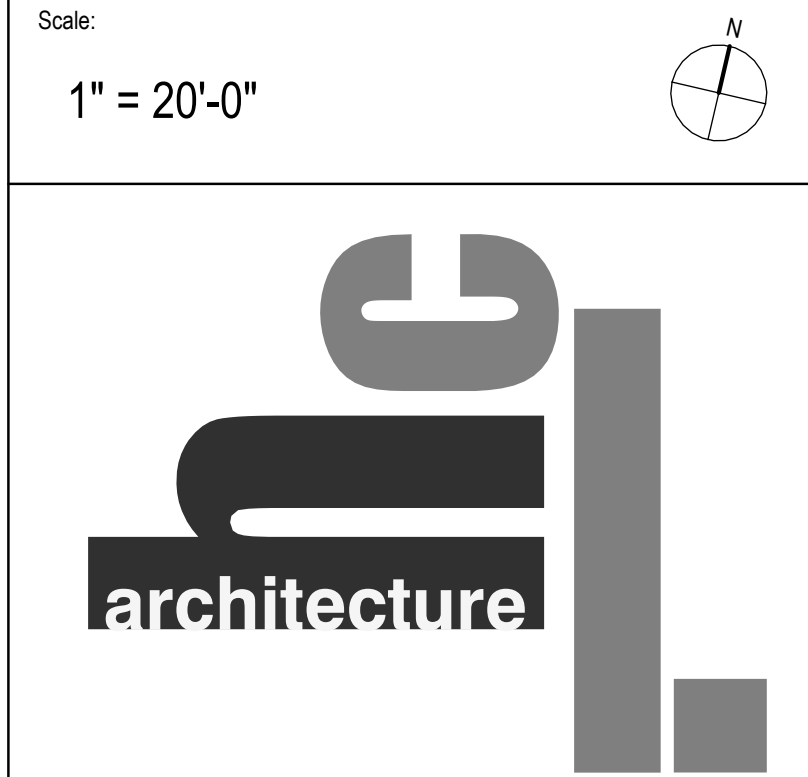

herman coliver locus  
 423 Tehama Street San Francisco, California 94103  
 T 415.495.1776 E info@hclarchitecture.com

Drawn By: ER  
 Date: 2/27/2026 1:59:37 PM

Sheet Number:  
**A1.1**

1 SITE PLAN  
 A1.1  
 1" = 20'-0"

IF THIS SHEET IS SMALLER THAN 30"x42" THEN IT HAS BEEN REDUCED

**OWNER'S STATEMENT**

THE UNDERSIGNED, CITY AND COUNTY OF SAN FRANCISCO, DOES HEREBY STATE THAT IT IS THE OWNER OF THE LAND DELINEATED AND EMBRACED WITHIN THE EXTERIOR BOUNDARY LINES ON THE HEREIN EMBODIED MAP ENTITLED "PARCEL MAP \_\_\_\_\_," CITY AND COUNTY OF SAN FRANCISCO, STATE OF CALIFORNIA; THAT SAID OWNERS ACQUIRED TITLE TO SAID LAND BY VIRTUE OF THE GRANT DEED FILED ON ...; THAT SAID OWNER DOES HEREBY CONSENT TO THE PREPARATION AND FILING OF THIS MAP.

IN WITNESS THEREOF, THE UNDERSIGNED HAS EXECUTED THIS STATEMENT THE DATE HEREUNDER WRITTEN.

CITY AND COUNTY OF SAN FRANCISCO,  
A CHARTERED CITY AND COUNTY

BY: \_\_\_\_\_ DATED: \_\_\_\_\_

NAME: \_\_\_\_\_

TITLE: \_\_\_\_\_

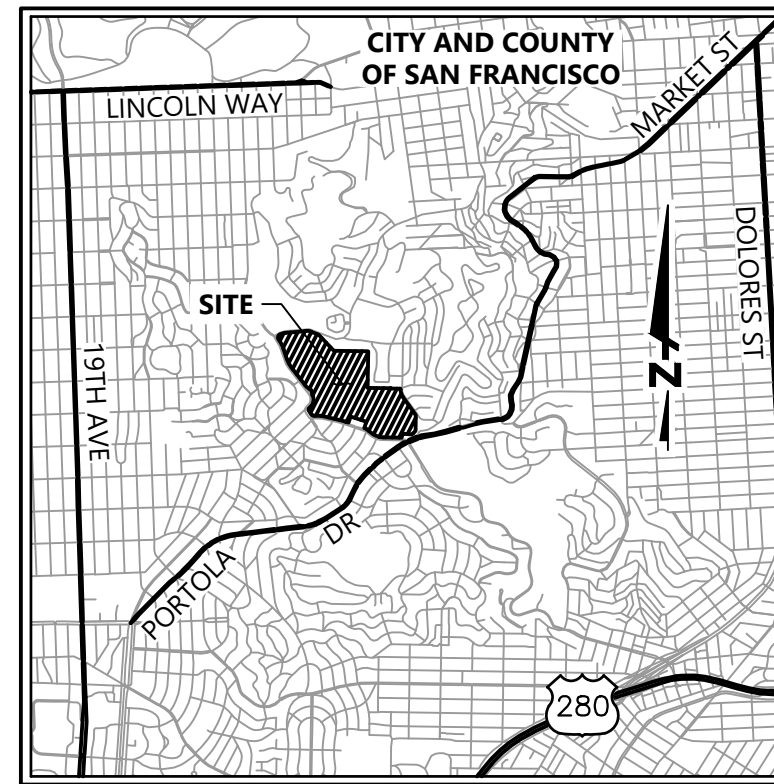

**VICINITY MAP**  
NOT TO SCALE

**CITY AND COUNTY SURVEYOR'S STATEMENT**

I HEREBY STATE THAT I HAVE EXAMINED THIS MAP; THAT THE SUBDIVISION AS SHOWN IS SUBSTANTIALLY THE SAME AS IT APPEARED ON THE TENTATIVE MAP, IF ANY, AND ANY APPROVED ALTERATION THEREOF; THAT ALL PROVISIONS OF THE CALIFORNIA SUBDIVISION MAP ACT AND ANY LOCAL ORDINANCE APPLICABLE AT THE TIME OF APPROVAL OF THE TENTATIVE MAP, IF ANY, HAVE BEEN COMPLIED WITH; AND THAT I AM SATISFIED THIS MAP IS TECHNICALLY CORRECT.

\_\_\_\_\_  
WILLIAM E. BLACKWELL JR., P.L.S. NO. 8251  
ACTING CITY AND COUNTY SURVEYOR  
CITY AND COUNTY OF SAN FRANCISCO

DATE: \_\_\_\_\_

**OWNER'S ACKNOWLEDGEMENT**

A NOTARY PUBLIC OR OTHER OFFICER COMPLETING THIS CERTIFICATE VERIFIES ONLY THE IDENTITY OF THE INDIVIDUAL WHO SIGNED THE DOCUMENT TO WHICH THIS CERTIFICATE IS ATTACHED AND NOT THE TRUTHFULNESS, ACCURACY, OR VALIDITY OF THAT DOCUMENT.

STATE OF \_\_\_\_\_ )

COUNTY OF \_\_\_\_\_ )

ON \_\_\_\_\_, 20\_\_\_\_, BEFORE ME, \_\_\_\_\_, A NOTARY PUBLIC, PERSONALLY APPEARED \_\_\_\_\_, WHO PROVED TO ME ON THE BASIS OF SATISFACTORY EVIDENCE TO BE THE PERSON(S) WHOSE NAME(S) IS/ARE SUBSCRIBED TO THE WITHIN INSTRUMENT AND ACKNOWLEDGED TO ME THAT HE/SHE/THEY EXECUTED THE SAME IN HIS/HER/THEIR AUTHORIZED CAPACITY(IES), AND THAT BY HIS/HER/THEIR SIGNATURE(S) ON THE INSTRUMENT THE PERSON(S) OR THE ENTITY UPON BEHALF OF WHICH THE PERSON(S) ACTED, EXECUTED THE INSTRUMENT.

I CERTIFY UNDER PENALTY OF PERJURY UNDER THE LAWS OF THE STATE OF CALIFORNIA THAT THE FOREGOING PARAGRAPH IS TRUE AND CORRECT.

WITNESS MY HAND AND OFFICIAL SEAL.

SIGNATURE: \_\_\_\_\_ NOTARY PUBLIC IN AND FOR SAID COUNTY AND STATE PRINTED NAME \_\_\_\_\_

STATE OF CALIFORNIA COMMISSION NO.: \_\_\_\_\_

MY COMMISSION EXPIRES: \_\_\_\_\_

COUNTY OF PRINCIPAL PLACE OF BUSINESS: \_\_\_\_\_

**SURVEYOR'S STATEMENT**

THIS MAP WAS PREPARED BY ME OR UNDER MY DIRECTION AND IS BASED UPON A FIELD SURVEY IN CONFORMANCE WITH THE REQUIREMENTS OF THE SUBDIVISION MAP ACT AND LOCAL ORDINANCE AT THE REQUEST OF MERCY HOUSING, IN MAY 2025. I HEREBY STATE THAT THIS PARCEL MAP SUBSTANTIALLY CONFORMS TO THE APPROVED OR CONDITIONALLY APPROVED TENTATIVE MAP, IF ANY. I FURTHER STATE THAT ALL MONUMENTS ARE OF THE CHARACTER AND OCCUPY THE POSITIONS INDICATED, OR THAT THEY WILL BE SET IN THOSE POSITIONS ON OR BEFORE \_\_\_\_\_ AND THAT THE MONUMENTS ARE, OR WILL BE, SUFFICIENT TO ENABLE THE SURVEY TO BE RETRACED.

\_\_\_\_\_  
DAVIS THRESH, P.L.S. NO. 6868

DATE: \_\_\_\_\_

**RECORDER'S STATEMENT**

FILED THIS \_\_\_\_\_ DAY OF \_\_\_\_\_, 20\_\_\_\_, AT \_\_\_\_\_ M., IN BOOK \_\_\_\_\_ OF \_\_\_\_\_ AT PAGES \_\_\_\_\_, AT THE REQUEST OF \_\_\_\_\_.

BY: \_\_\_\_\_  
COUNTY RECORDER

**PARCEL MAP**

BEING A SUBDIVISION OF LOT 7, ASSESSOR'S BLOCK 2842, AND BEING ALSO A PORTION OF THE "ALMS HOUSE TRACT" FILED MAY 21, 1909 IN BOOK G OF MAPS, PAGE 52; BOOK 794 OF DEEDS, PAGE 68, RECORDED MARCH 5, 1914; BOOK 2002 OF OFFICIAL RECORDS, PAGE 1, RECORDED MARCH 30, 1930; AND BOOK 5895 OF OFFICIAL RECORDS, PAGE 245, RECORDED MARCH 25, 1952 IN THE CITY AND COUNTY OF SAN FRANCISCO

CITY AND COUNTY OF SAN FRANCISCO  
STATE OF CALIFORNIA  
APRIL 2026

PREPARED BY



**BKF ENGINEERS**  
7901 STONERIDGE DRIVE  
SUITE 360  
PLEASANTON, CA 94588  
(925) 396-7700  
www.bkf.com

CLARENDON AVE  
(WIDTH VARIES)

CLARENDON AVE  
(WIDTH VARIES)

LANDS OF  
CITY AND COUNTY OF SAN FRANCISCO  
LOT 009, BLOCK 2842

LANDS OF  
WESTERN DIOCESE OF THE ARMENIA  
LOT 010, BLOCK 2842

LAGUNA HONDA BLVD  
(WIDTH VARIES)

**PARCEL 2**  
1.478 AC±  
64,393 SF±

AB 2842  
LOT 07

**PARCEL 1**  
73.483 AC±

26.00' ACCESS  
EASEMENT

WOODSIDE AVE  
(WIDTH VARIES)

LANDS OF  
255 WOODSIDE HOUSING ASSOCIATES, L.P.  
D.N. 2015-K156272-00  
LOT 008, BLOCK 2842

MIDTOWN TERRACE  
SUBDIVISION NO. 3  
"R" M 68-70

**BASIS OF BEARINGS**

THE BEARING OF NORTH 85°27'23" WEST ALONG THE MONUMENT LINE ON OLYMPIA WAY AS SHOWN ON THE MAP ENTITLED "MIDTOWN TERRACE SUBDIVISION NO. 3", RECORDED ON JULY 27, 1955, IN BOOK "R" AT PAGES 68-70, INCLUSIVE, IN THE OFFICE OF THE RECORDER OF THE CITY AND COUNTY OF SAN FRANCISCO WAS TAKEN AS THE BASIS OF BEARINGS FOR THIS SURVEY.

**NOTES**

1. ALL DISTANCES AND DIMENSIONS ARE IN FEET AND DECIMALS THEREOF.
2. ALL TIES ARE PERPENDICULAR UNLESS NOTED OTHERWISE.
3. THE FIELD SURVEY FOR THIS MAP WAS COMPLETED ON 05/07/2025. ALL PHYSICAL DETAILS INCLUDING CITY AND PRIVATE MONUMENTATION SHOWN HEREON EXISTED AS OF THE FIELD SURVEY COMPLETION DATE, UNLESS OTHERWISE NOTED.

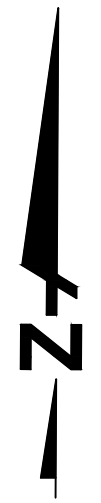
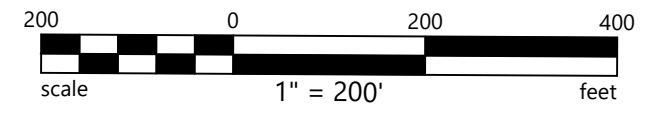

**ABBREVIATIONS**

±	MORE OR LESS
Δ	DELTA
AB	ASSESSOR'S BLOCK
AC	ACRES
APN	ASSESSOR'S PARCEL NUMBER
BM	BENCHMARK
DN	DOCUMENT NUMBER
ESMT	EASEMENT
IP	IRON PIPE
L	LENGTH
MON	MONUMENT
O.R.	OFFICIAL RECORDS
R	RADIUS
(R)	RADIAL BEARING
R/W	RIGHT OF WAY
SF	SQUARE FEET
(T)	TOTAL

**SYMBOLS & LEGEND**

	FOUND CITY MONUMENT (LEAD AND PIN UNLESS OTHERWISE NOTED)
	SEARCHED FOR MONUMENT, NOT FOUND
	SUBDIVISION BOUNDARY
	NEW INTERIOR LOT LINE
	EASEMENT
	CENTER LINE
	MONUMENT LINE
	SURVEY TIE

**REFERENCES**

- R1 "RECORD OF SURVEY NO. 5617", FILED FOR RECORD ON MAY 26, 2009, IN BOOK CC OF SURVEY MAPS, AT PAGES 143-146.
- R2 MAP OF "MIDTOWN TERRACE SUBDIVISION NO. 2", FILED FOR RECORD ON JUNE 5, 1952, IN MAP BOOK "R" AT PAGES 28-30.
- R3 MAP OF "MIDTOWN TERRACE SUBDIVISION NO. 3", FILED FOR RECORD ON JULY 27, 1955, IN MAP BOOK "R" AT PAGES 68-70.

**PARCEL MAP**

BEING A SUBDIVISION OF LOT 7, ASSESSOR'S BLOCK 2842, AND BEING ALSO A PORTION OF THE "ALMS HOUSE TRACT" FILED MAY 21, 1909 IN BOOK G OF MAPS, PAGE 52; BOOK 794 OF DEEDS, PAGE 68, RECORDED MARCH 5, 1914; BOOK 2002 OF OFFICIAL RECORDS, PAGE 1, RECORDED MARCH 30, 1930; AND BOOK 5895 OF OFFICIAL RECORDS, PAGE 245, RECORDED MARCH 25, 1952 IN THE CITY AND COUNTY OF SAN FRANCISCO

CITY AND COUNTY OF SAN FRANCISCO  
STATE OF CALIFORNIA  
APRIL 2026

PREPARED BY



**BKF ENGINEERS**  
7901 STONERIDGE DRIVE  
SUITE 360  
PLEASANTON, CA 94588  
(925) 396-7700  
www.bkf.com

DRAWING NAME: C:\temp\ac\publish\2842\210467\_L15H1\_BNDY-Working.dwg  
PLOT DATE: 04-09-26 PLOTTED BY: mmh



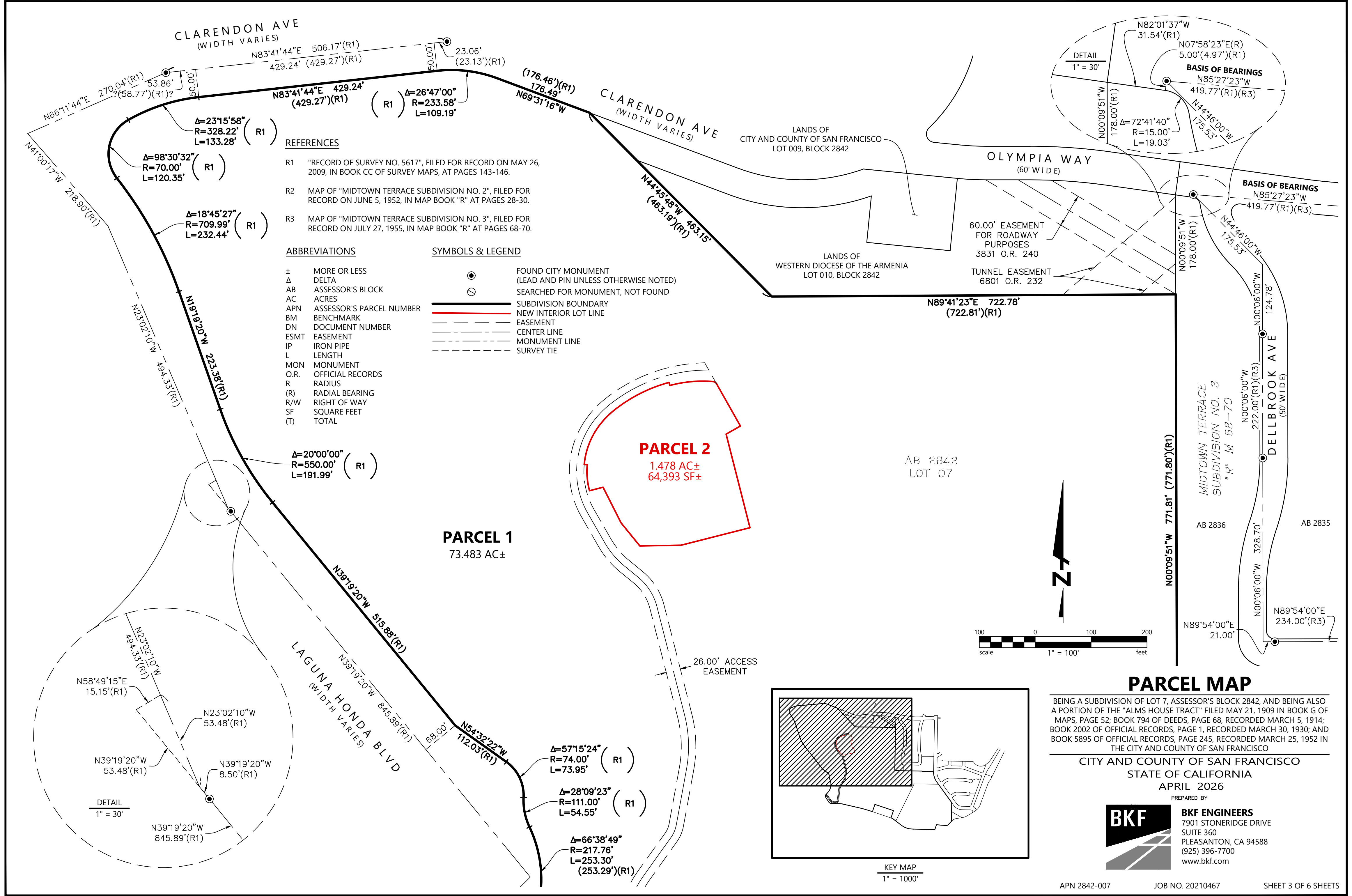

**REFERENCES**

- R1 "RECORD OF SURVEY NO. 5617", FILED FOR RECORD ON MAY 26, 2009, IN BOOK CC OF SURVEY MAPS, AT PAGES 143-146.
- R2 MAP OF "MIDTOWN TERRACE SUBDIVISION NO. 2", FILED FOR RECORD ON JUNE 5, 1952, IN MAP BOOK "R" AT PAGES 28-30.
- R3 MAP OF "MIDTOWN TERRACE SUBDIVISION NO. 3", FILED FOR RECORD ON JULY 27, 1955, IN MAP BOOK "R" AT PAGES 68-70.

**ABBREVIATIONS**

- ± MORE OR LESS
- Δ DELTA
- AB ASSESSOR'S BLOCK
- AC ACRES
- APN ASSESSOR'S PARCEL NUMBER
- BM BENCHMARK
- DN DOCUMENT NUMBER
- ESMT EASEMENT
- IP IRON PIPE
- L LENGTH
- MON MONUMENT
- O.R. OFFICIAL RECORDS
- R RADIUS
- (R) RADIAL BEARING
- R/W RIGHT OF WAY
- SF SQUARE FEET
- (T) TOTAL

**SYMBOLS & LEGEND**

- FOUND CITY MONUMENT (LEAD AND PIN UNLESS OTHERWISE NOTED)
- SEARCHED FOR MONUMENT, NOT FOUND
- SUBDIVISION BOUNDARY
- NEW INTERIOR LOT LINE
- EASEMENT
- CENTER LINE
- MONUMENT LINE
- SURVEY TIE

Δ=20°00'00"  
R=550.00'  
L=191.99' (R1)

**PARCEL 1**  
73.483 AC±

**PARCEL 2**  
1.478 AC±  
64,393 SF±

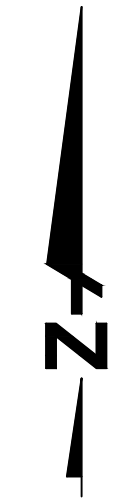
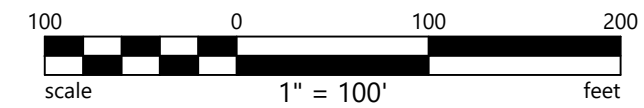

**PARCEL MAP**

BEING A SUBDIVISION OF LOT 7, ASSESSOR'S BLOCK 2842, AND BEING ALSO A PORTION OF THE "ALMS HOUSE TRACT" FILED MAY 21, 1909 IN BOOK G OF MAPS, PAGE 52; BOOK 794 OF DEEDS, PAGE 68, RECORDED MARCH 5, 1914; BOOK 2002 OF OFFICIAL RECORDS, PAGE 1, RECORDED MARCH 30, 1930; AND BOOK 5895 OF OFFICIAL RECORDS, PAGE 245, RECORDED MARCH 25, 1952 IN THE CITY AND COUNTY OF SAN FRANCISCO

CITY AND COUNTY OF SAN FRANCISCO  
STATE OF CALIFORNIA  
APRIL 2026



**BKF ENGINEERS**  
7901 STONERIDGE DRIVE  
SUITE 360  
PLEASANTON, CA 94588  
(925) 396-7700  
www.bkf.com

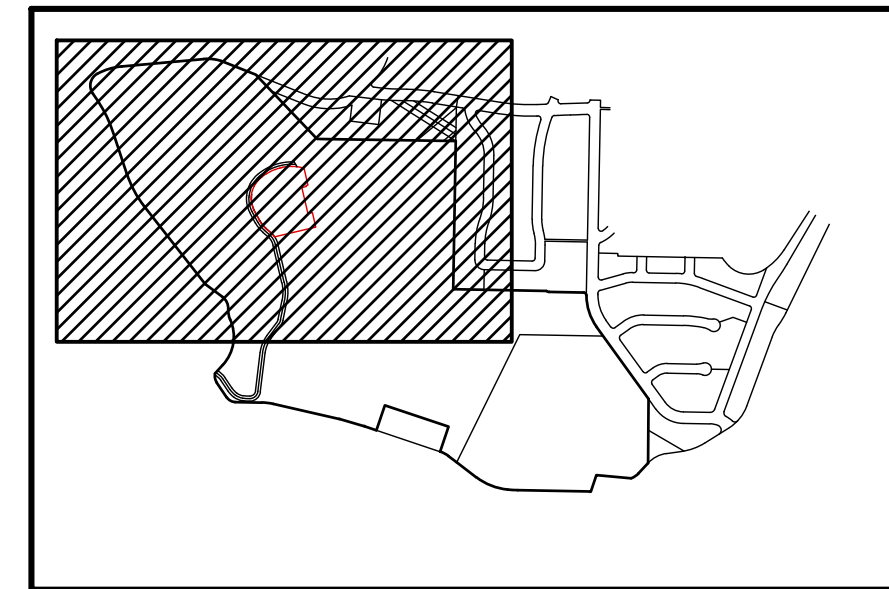

KEY MAP  
1" = 1000'

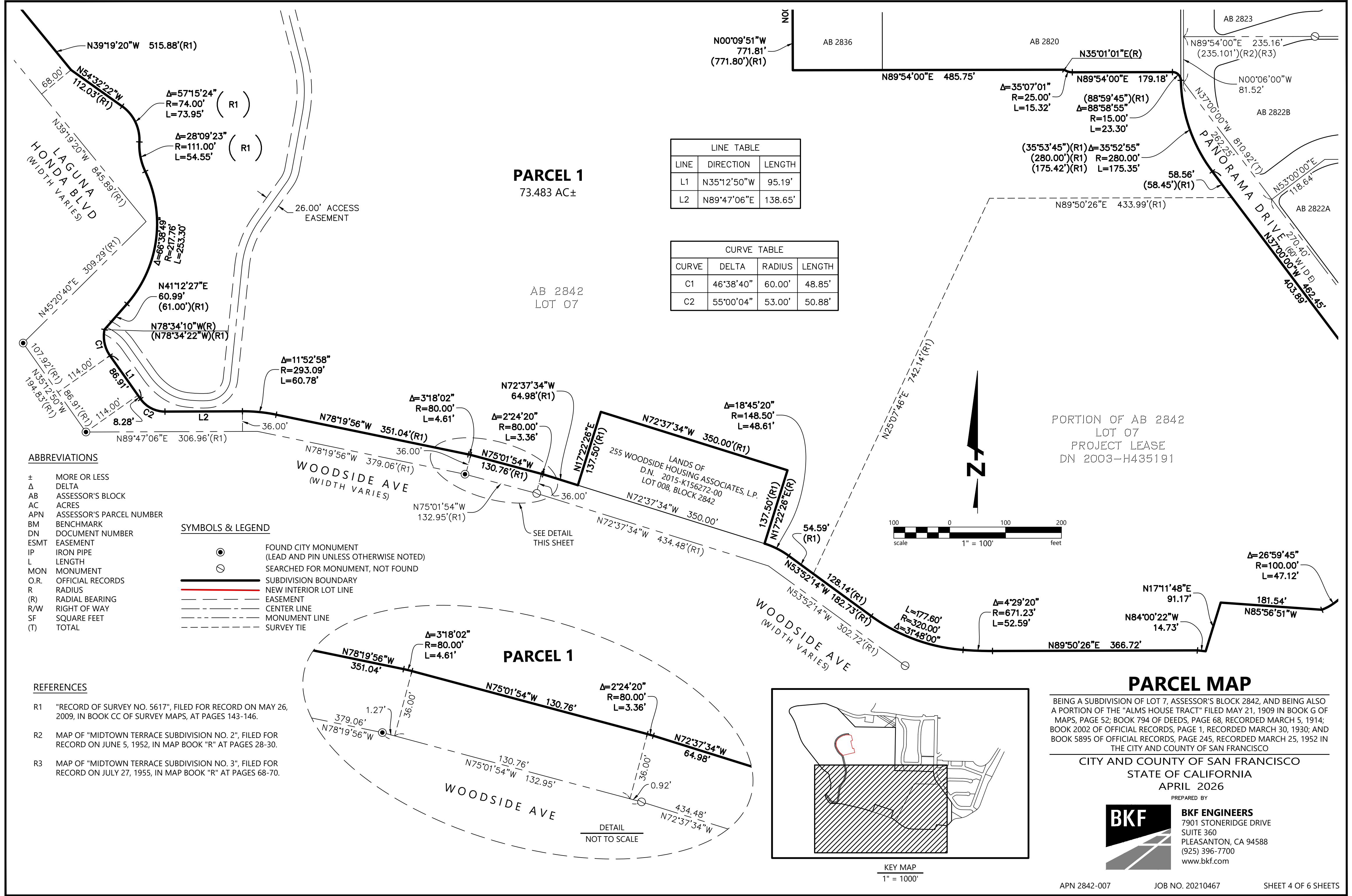

**PARCEL 1**  
73.483 AC±

AB 2842  
LOT 07

LINE TABLE

LINE	DIRECTION	LENGTH
L1	N35°12'50"W	95.19'
L2	N89°47'06"E	138.65'

CURVE TABLE

CURVE	DELTA	RADIUS	LENGTH
C1	46°38'40"	60.00'	48.85'
C2	55°00'04"	53.00'	50.88'

**ABBREVIATIONS**

- ± MORE OR LESS
- Δ DELTA
- AB ASSESSOR'S BLOCK
- AC ACRES
- APN ASSESSOR'S PARCEL NUMBER
- BM BENCHMARK
- DN DOCUMENT NUMBER
- ESMT EASEMENT
- IP IRON PIPE
- L LENGTH
- MON MONUMENT
- O.R. OFFICIAL RECORDS
- R RADIUS
- (R) RADIAL BEARING
- R/W RIGHT OF WAY
- SF SQUARE FEET
- (T) TOTAL

**SYMBOLS & LEGEND**

- FOUND CITY MONUMENT (LEAD AND PIN UNLESS OTHERWISE NOTED)
- SEARCHED FOR MONUMENT, NOT FOUND
- SUBDIVISION BOUNDARY
- NEW INTERIOR LOT LINE
- - - EASEMENT
- - - CENTER LINE
- - - MONUMENT LINE
- - - SURVEY TIE

**REFERENCES**

- R1 "RECORD OF SURVEY NO. 5617", FILED FOR RECORD ON MAY 26, 2009, IN BOOK CC OF SURVEY MAPS, AT PAGES 143-146.
- R2 MAP OF "MIDTOWN TERRACE SUBDIVISION NO. 2", FILED FOR RECORD ON JUNE 5, 1952, IN MAP BOOK "R" AT PAGES 28-30.
- R3 MAP OF "MIDTOWN TERRACE SUBDIVISION NO. 3", FILED FOR RECORD ON JULY 27, 1955, IN MAP BOOK "R" AT PAGES 68-70.

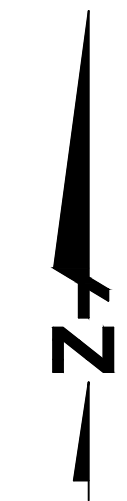
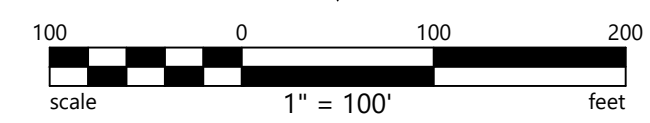
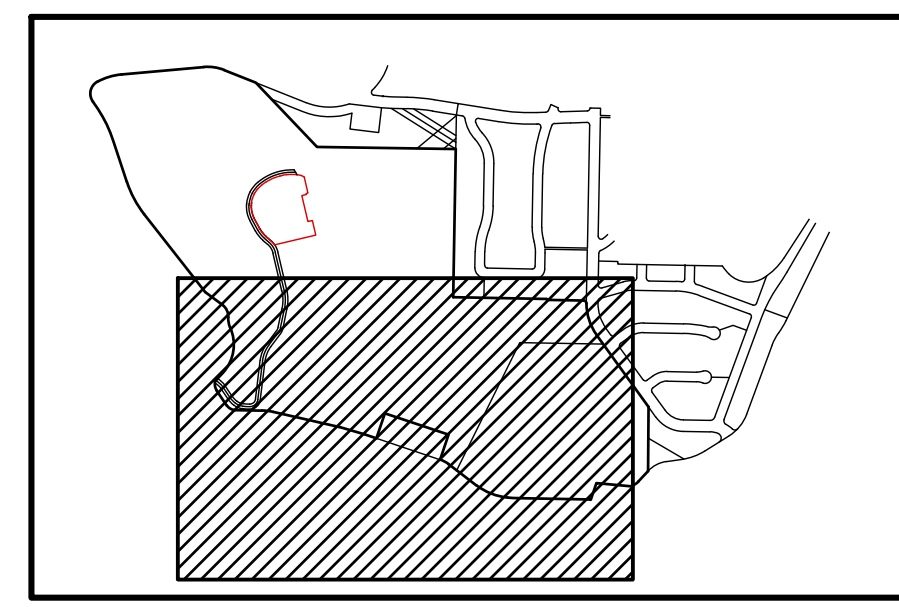
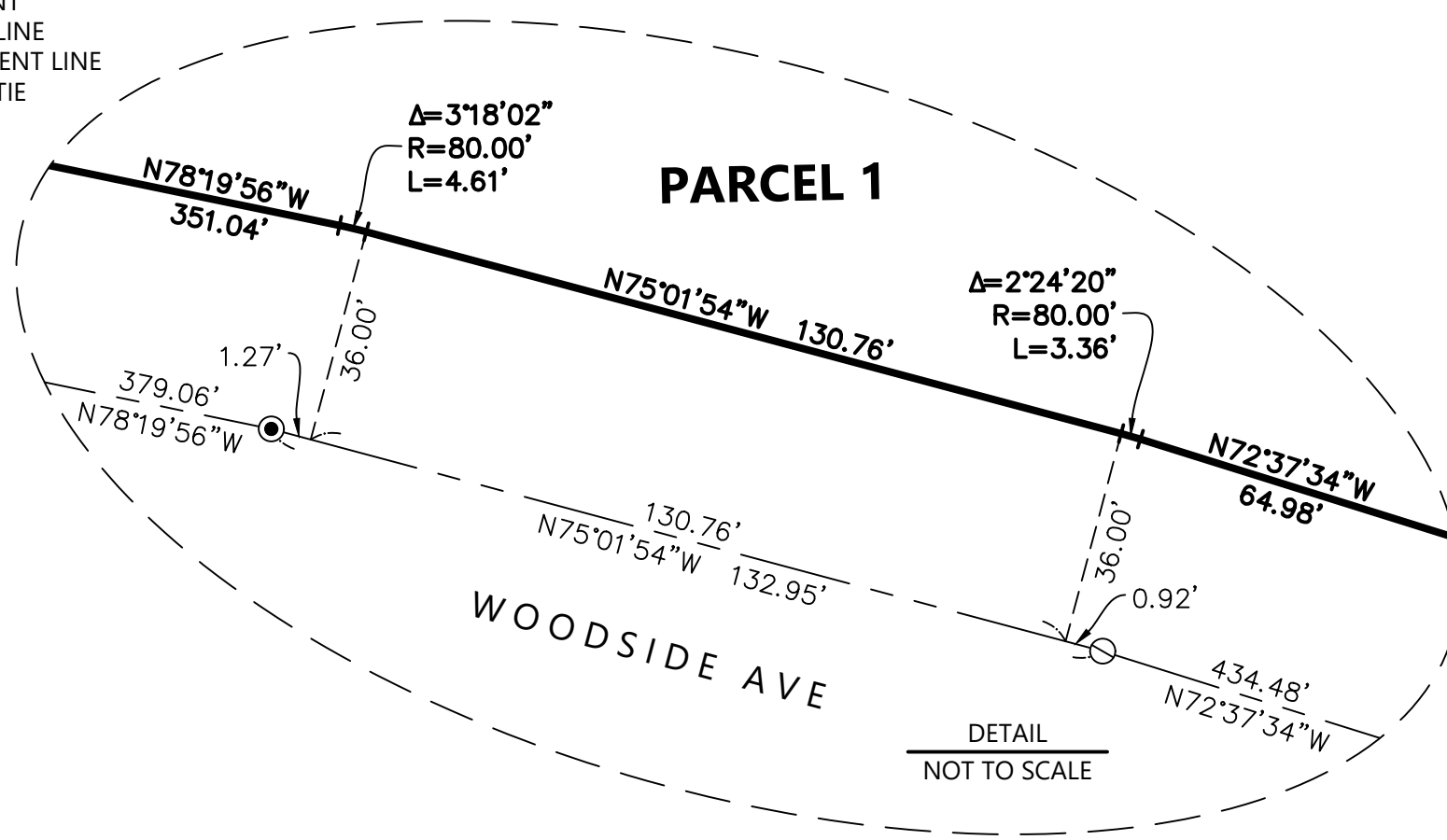

PORTION OF AB 2842  
LOT 07  
PROJECT LEASE  
DN 2003-H435191

**PARCEL MAP**

BEING A SUBDIVISION OF LOT 7, ASSESSOR'S BLOCK 2842, AND BEING ALSO A PORTION OF THE "ALMS HOUSE TRACT" FILED MAY 21, 1909 IN BOOK G OF MAPS, PAGE 52; BOOK 794 OF DEEDS, PAGE 68, RECORDED MARCH 5, 1914; BOOK 2002 OF OFFICIAL RECORDS, PAGE 1, RECORDED MARCH 30, 1930; AND BOOK 5895 OF OFFICIAL RECORDS, PAGE 245, RECORDED MARCH 25, 1952 IN THE CITY AND COUNTY OF SAN FRANCISCO

CITY AND COUNTY OF SAN FRANCISCO  
STATE OF CALIFORNIA  
APRIL 2026

PREPARED BY

**BKF ENGINEERS**  
7901 STONERIDGE DRIVE  
SUITE 360  
PLEASANTON, CA 94588  
(925) 396-7700  
www.bkf.com

DRAWING NAME: C:\temp\AcPublish\28420467\_LHSI\_BNDY-Working.dwg      PLOTTED BY: mmh

**REFERENCES**

- R1 "RECORD OF SURVEY NO. 5617", FILED FOR RECORD ON MAY 26, 2009, IN BOOK CC OF SURVEY MAPS, AT PAGES 143-146.
- R2 MAP OF "MIDTOWN TERRACE SUBDIVISION NO. 2", FILED FOR RECORD ON JUNE 5, 1952, IN MAP BOOK "R" AT PAGES 28-30.
- R3 MAP OF "MIDTOWN TERRACE SUBDIVISION NO. 3", FILED FOR RECORD ON JULY 27, 1955, IN MAP BOOK "R" AT PAGES 68-70.

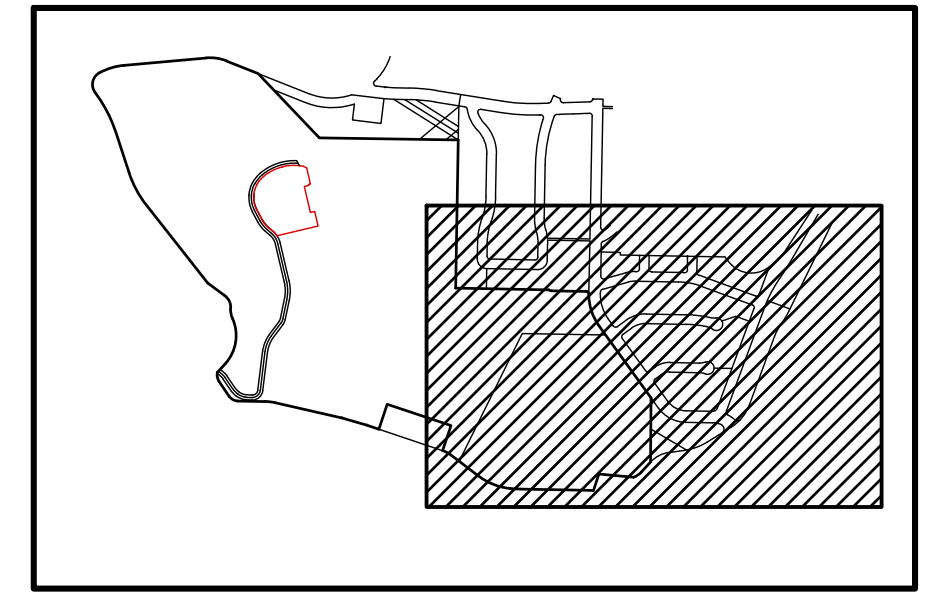

KEY MAP  
1" = 1000'

**ABBREVIATIONS**

- ± MORE OR LESS
- Δ DELTA
- AB ASSESSOR'S BLOCK
- AC ACRES
- APN ASSESSOR'S PARCEL NUMBER
- BM BENCHMARK
- DN DOCUMENT NUMBER
- ESMT EASEMENT
- IP IRON PIPE
- L LENGTH
- MON MONUMENT
- O.R. OFFICIAL RECORDS
- R RADIUS
- (R) RADIAL BEARING
- R/W RIGHT OF WAY
- SF SQUARE FEET
- (T) TOTAL

**SYMBOLS & LEGEND**

- FOUND CITY MONUMENT (LEAD AND PIN UNLESS OTHERWISE NOTED)
- SEARCHED FOR MONUMENT, NOT FOUND
- SUBDIVISION BOUNDARY
- NEW INTERIOR LOT LINE
- EASEMENT
- CENTER LINE
- MONUMENT LINE
- SURVEY TIE

**PARCEL MAP**

BEING A SUBDIVISION OF LOT 7, ASSESSOR'S BLOCK 2842, AND BEING ALSO A PORTION OF THE "ALMS HOUSE TRACT" FILED MAY 21, 1909 IN BOOK G OF MAPS, PAGE 52; BOOK 794 OF DEEDS, PAGE 68, RECORDED MARCH 5, 1914; BOOK 2002 OF OFFICIAL RECORDS, PAGE 1, RECORDED MARCH 30, 1930; AND BOOK 5895 OF OFFICIAL RECORDS, PAGE 245, RECORDED MARCH 25, 1952 IN THE CITY AND COUNTY OF SAN FRANCISCO

CITY AND COUNTY OF SAN FRANCISCO  
STATE OF CALIFORNIA  
APRIL 2026

PREPARED BY  
**BKF**  
**BKF ENGINEERS**  
7901 STONERIDGE DRIVE  
SUITE 360  
PLEASANTON, CA 94588  
(925) 396-7700  
www.bkf.com

APN 2842-007

JOB NO. 20210467

SHEET 5 OF 6 SHEETS

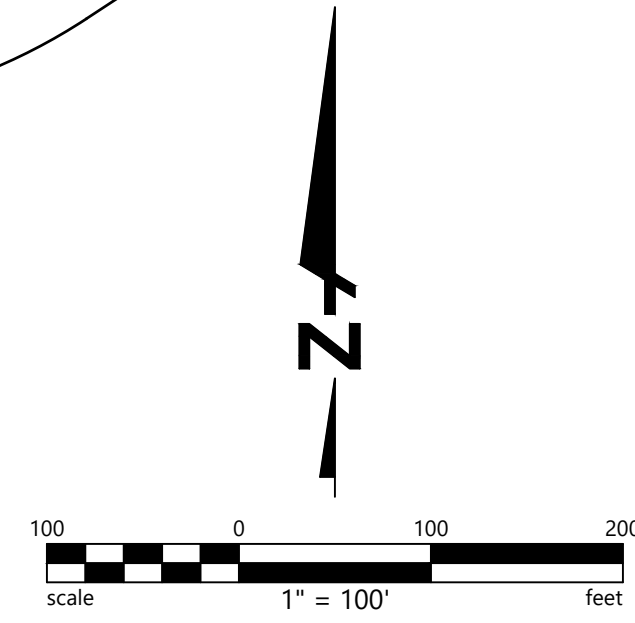
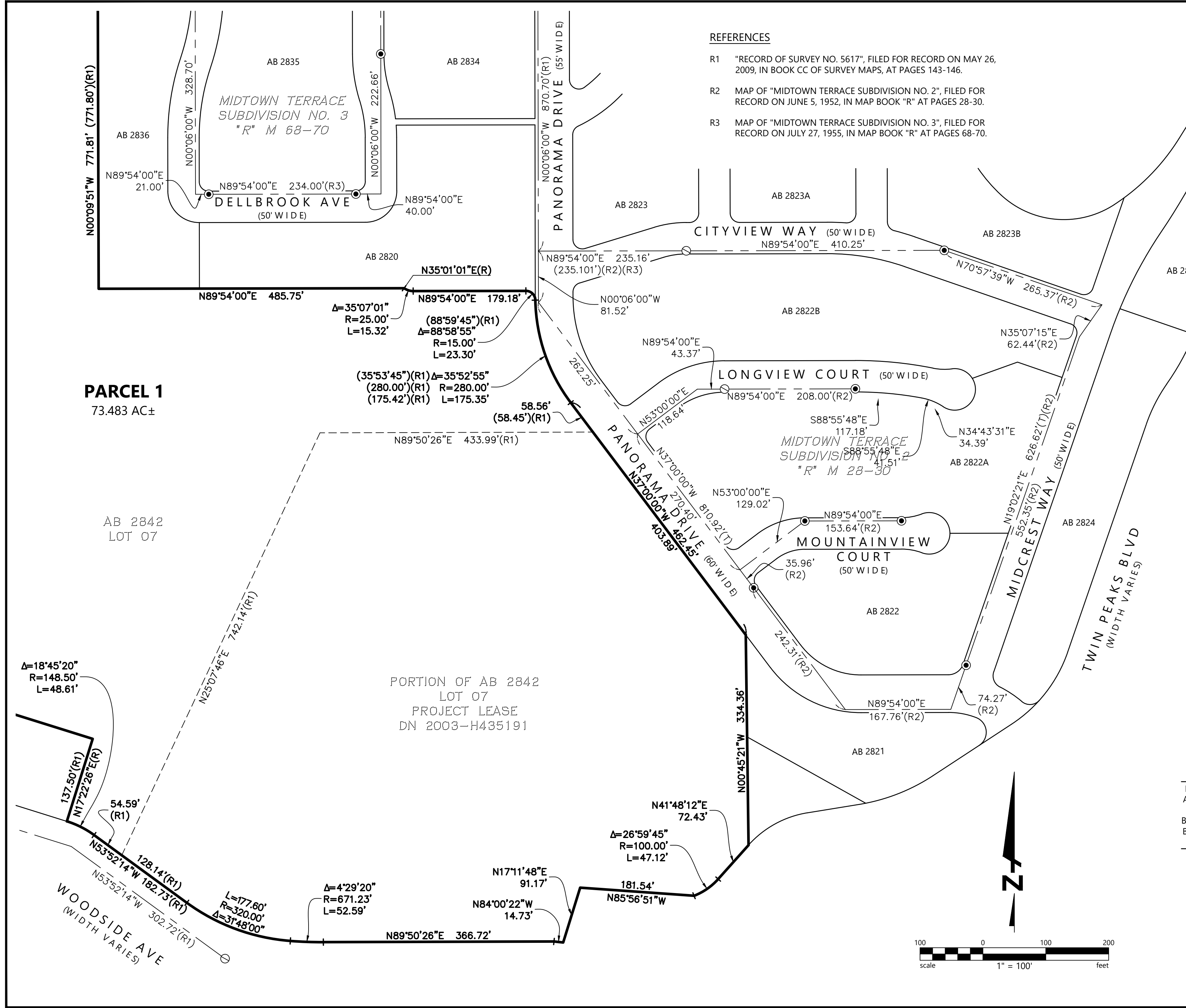

DRAWING NAME: C:\Temp\A\Public\2842\210467\_L\HSH\_BNDY-Working.dwg  
PLOT DATE: 04-09-26 PLOTTED BY: mmh

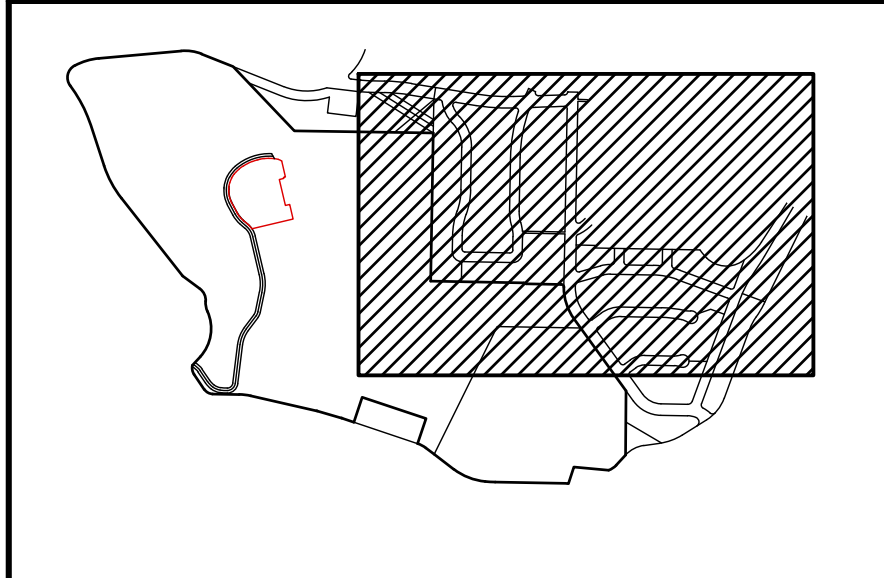
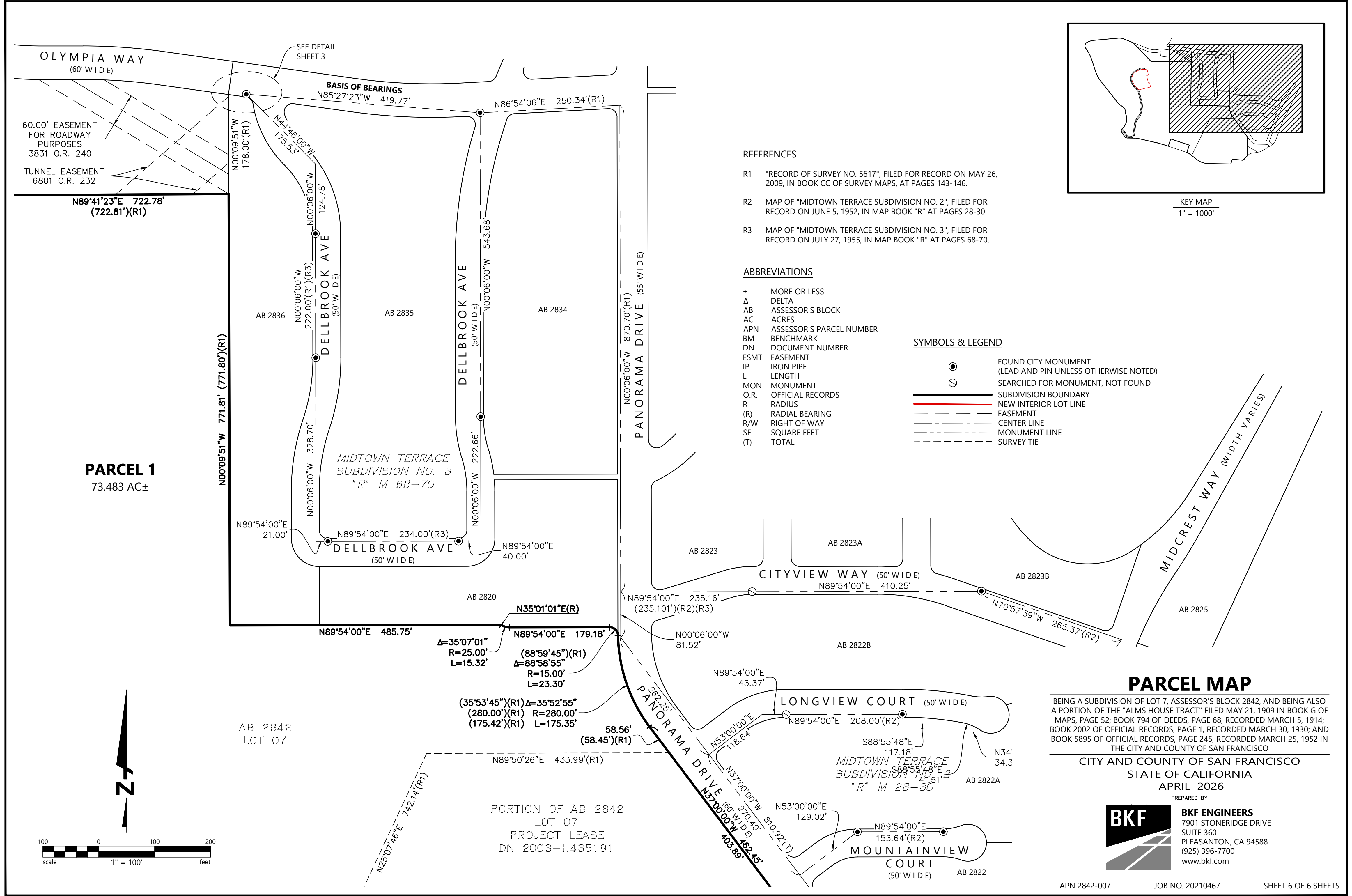

KEY MAP  
1" = 100'

**REFERENCES**

- R1 "RECORD OF SURVEY NO. 5617", FILED FOR RECORD ON MAY 26, 2009, IN BOOK CC OF SURVEY MAPS, AT PAGES 143-146.
- R2 MAP OF "MIDTOWN TERRACE SUBDIVISION NO. 2", FILED FOR RECORD ON JUNE 5, 1952, IN MAP BOOK "R" AT PAGES 28-30.
- R3 MAP OF "MIDTOWN TERRACE SUBDIVISION NO. 3", FILED FOR RECORD ON JULY 27, 1955, IN MAP BOOK "R" AT PAGES 68-70.

**ABBREVIATIONS**

- ± MORE OR LESS
- Δ DELTA
- AB ASSESSOR'S BLOCK
- AC ACRES
- APN ASSESSOR'S PARCEL NUMBER
- BM BENCHMARK
- DN DOCUMENT NUMBER
- ESMT EASEMENT
- IP IRON PIPE
- L LENGTH
- MON MONUMENT
- O.R. OFFICIAL RECORDS
- R RADIUS
- (R) RADIAL BEARING
- R/W RIGHT OF WAY
- SF SQUARE FEET
- (T) TOTAL

**SYMBOLS & LEGEND**

- FOUND CITY MONUMENT (LEAD AND PIN UNLESS OTHERWISE NOTED)
- SEARCHED FOR MONUMENT, NOT FOUND
- SUBDIVISION BOUNDARY
- NEW INTERIOR LOT LINE
- EASEMENT
- CENTER LINE
- MONUMENT LINE
- SURVEY TIE

**PARCEL 1**  
73.483 AC±

**PARCEL MAP**

BEING A SUBDIVISION OF LOT 7, ASSESSOR'S BLOCK 2842, AND BEING ALSO A PORTION OF THE "ALMS HOUSE TRACT" FILED MAY 21, 1909 IN BOOK G OF MAPS, PAGE 52; BOOK 794 OF DEEDS, PAGE 68, RECORDED MARCH 5, 1914; BOOK 2002 OF OFFICIAL RECORDS, PAGE 1, RECORDED MARCH 30, 1930; AND BOOK 5895 OF OFFICIAL RECORDS, PAGE 245, RECORDED MARCH 25, 1952 IN THE CITY AND COUNTY OF SAN FRANCISCO

CITY AND COUNTY OF SAN FRANCISCO  
STATE OF CALIFORNIA  
APRIL 2026

PREPARED BY



**BKF ENGINEERS**  
7901 STONERIDGE DRIVE  
SUITE 360  
PLEASANTON, CA 94588  
(925) 396-7700  
www.bkf.com

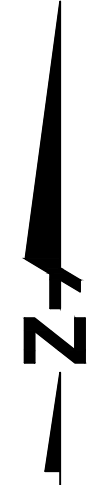
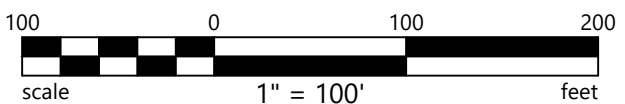

DRAWING NAME: C:\temp\ac\publish\282042\0467\_L\HSH\_BNDY\_Working.dwg PLOT DATE: 04-09-26 PLOTTED BY: mmh

## Exhibit “B”

### Project Schedule and Benchmarks

<b>PROJECT SCHEDULE Key Milestones through entitlements and project financing</b>	
January 2025 – April 2025	<ul style="list-style-type: none"> <li>- Presentation to Health Commission JCC - 2/3/25 and 4/14/25</li> <li>- Presentation to full Health Commission – 3/17/25 and 4/21/25</li> <li>- Outreach to LHH staff and residents as recommended by LHH</li> <li>- Coordination with Supervisor Melgar’s Office</li> <li>- Preliminary community outreach – presentations to neighborhood organizations</li> </ul>
Jan 2025 - Sept 2025	<ul style="list-style-type: none"> <li>- MOHCD Conceptual/Cost Containment Design Review process</li> <li>- Review SF Planning Design Standards adopted 11/14/24 by Planning Commission and incorporate</li> <li>- Architect prepares revisions to master plan based on financing constraints and feedback from stakeholders, presents Concept Design to MOHCD and DPH,</li> <li>- services planning to determine services approach (providing an Enhanced Services or providing affordable Assisted Living model)</li> </ul>
October 2025	<p>Submit Planning Entitlements application (SB 330) Community Meeting – inviting neighbors from neighborhoods neighboring LHH</p>
October 2025	SB 330 application allowing Planning to do Tribal consultation pre Entitlement Review
November 2025	LHH detailed review of Site Plan and revisions to address LHH circulation needs.
Spring 2026	SB 423 Application to Planning for entitlements submitted
April 2026	Parcel subdivision application submitted to DPW
April 2026	JCC review and requested approval of MOU and endorsement of resolution regarding MOU and jurisdictional transfer
May 2026	Health Commission review and requested approval of MOU and jurisdictional transfer
Spring '26- Winter '26	<ul style="list-style-type: none"> <li>Project’s Design Development and Construction documents developed</li> <li>Building permit application (submitted once entitlements are approved)</li> <li>Continue Community outreach</li> <li>Select ECEC provider</li> <li>Services planning to refine services plan</li> </ul>
Spring '27	Resolution from Health Commission and BOS approval of jurisdictional transfer
January '27	Option to Ground Lease executed for financing applications.

	*If parcel subdivision and Health Commission and BOS resolution allowing jurisdictional transfer has not occurred, then the Option to Ground Lease will be CCSF acting through DPH with transferability to MOHCD (upon approval of the jurisdictional transfer)
Feb or March '27	TCAC/CDLAC application Due date of application will be known at the end of 2026.
April '27	Estimated date of Parcel subdivision Map approved New Senior Housing Parcel recorded and created
December 2027	Building permit pulled immediately prior to construction loan closing Tax Credit Syndication/Construction loan closing Earliest potential start of construction
December 2029	TCO received for residential building
January - April 2030	Residential occupants move in ECEC Tenant Improvements begin
Fall 2030	Estimated ECEC start of operations and children
<b>ROLES AND RESPONSIBILITIES</b>	
MOHCD	<ul style="list-style-type: none"> <li>- Predevelopment and Permanent Financing Lender (and provision of certain types of subsidies)</li> <li>- Facilitating bond issuance by City</li> <li>- Jurisdictional transfer</li> <li>- Monitoring and oversight through development, construction, and operations</li> <li>- Ground Lessor</li> <li>- Staff costs</li> </ul>
DPH / Laguna Honda Hospital	<ul style="list-style-type: none"> <li>- Provide site</li> <li>- DPH Commission approval of land use path</li> <li>- Participation and feedback around design</li> <li>- Collaboration and planning around potential program synergies between LHH and the new affordable housing</li> <li>- Coordinate campus infrastructure issues such as utilities, hospital logistics and operations</li> <li>- Coordination around other hospital capital projects</li> <li>- Potential jurisdictional transfer</li> <li>- Staff costs</li> </ul>
Developer	<ul style="list-style-type: none"> <li>- Developer</li> <li>- Coordination around LHH campus infrastructure issues such as utilities, hospital logistics and operations</li> <li>- Coordination around hospital capital projects</li> <li>- Collaboration and planning around potential program synergies between LHH and the new affordable housing</li> <li>- Housing operator</li> </ul>

	<ul style="list-style-type: none"><li>- Service provider</li><li>- Ground lessee</li><li>- Predevelopment expenses (under the MOHCD loan)</li></ul>
--	---

**Exhibit “C”- Draft Logistics Plan**



DRAFT



## Trucking Route - All Construction Phases

Typical working hours for all phases - 7:00am - 3:30pm

Gate A - Will be built at the end of the grading phase (approx. month 3 of construction) and will be used for the largest deliveries, ex. wall panels and rebar. Also the access point for mobile crane and concrete pumps

Gate B - Is the existing access point to the site and will be primarily used early on for the grading phase. This gate will remain active in a smaller capacity for debris box swap outs

Gate C - Will also be created at the end of the grading phase (approx. month 3 of construction) and will accommodate smaller trucks and small material deliveries (ex. pickups and conex boxes)

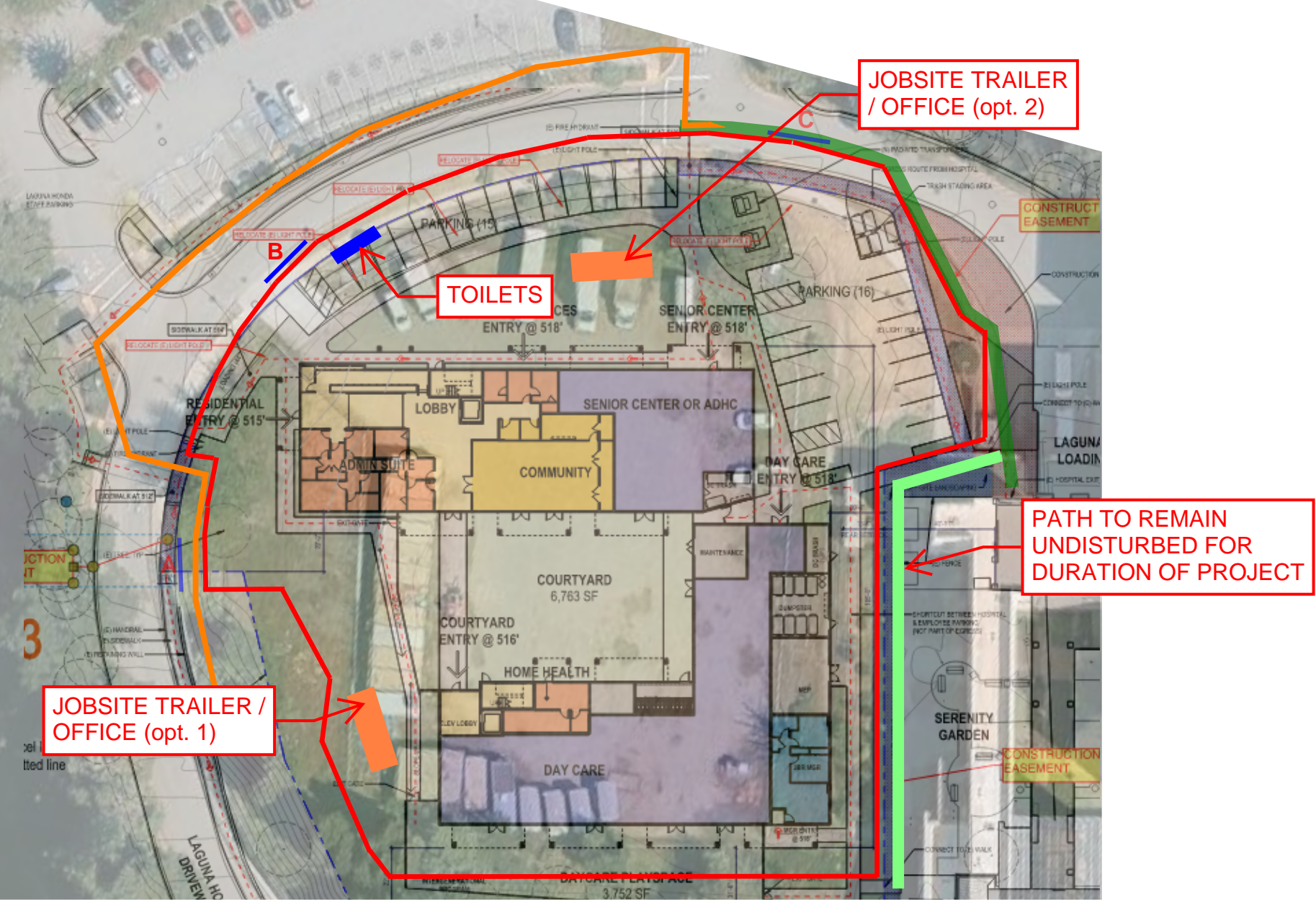

### Logistics Plan - Grading & Ground Improvements

-  Construction Fence - Typically on PL (except temp road and SW corner)
-  Temporary Pedestrian Walkway (for duration of construction)
-  Gates - see page 1 for timing
-  Pedestrian Route (for duration of construction)

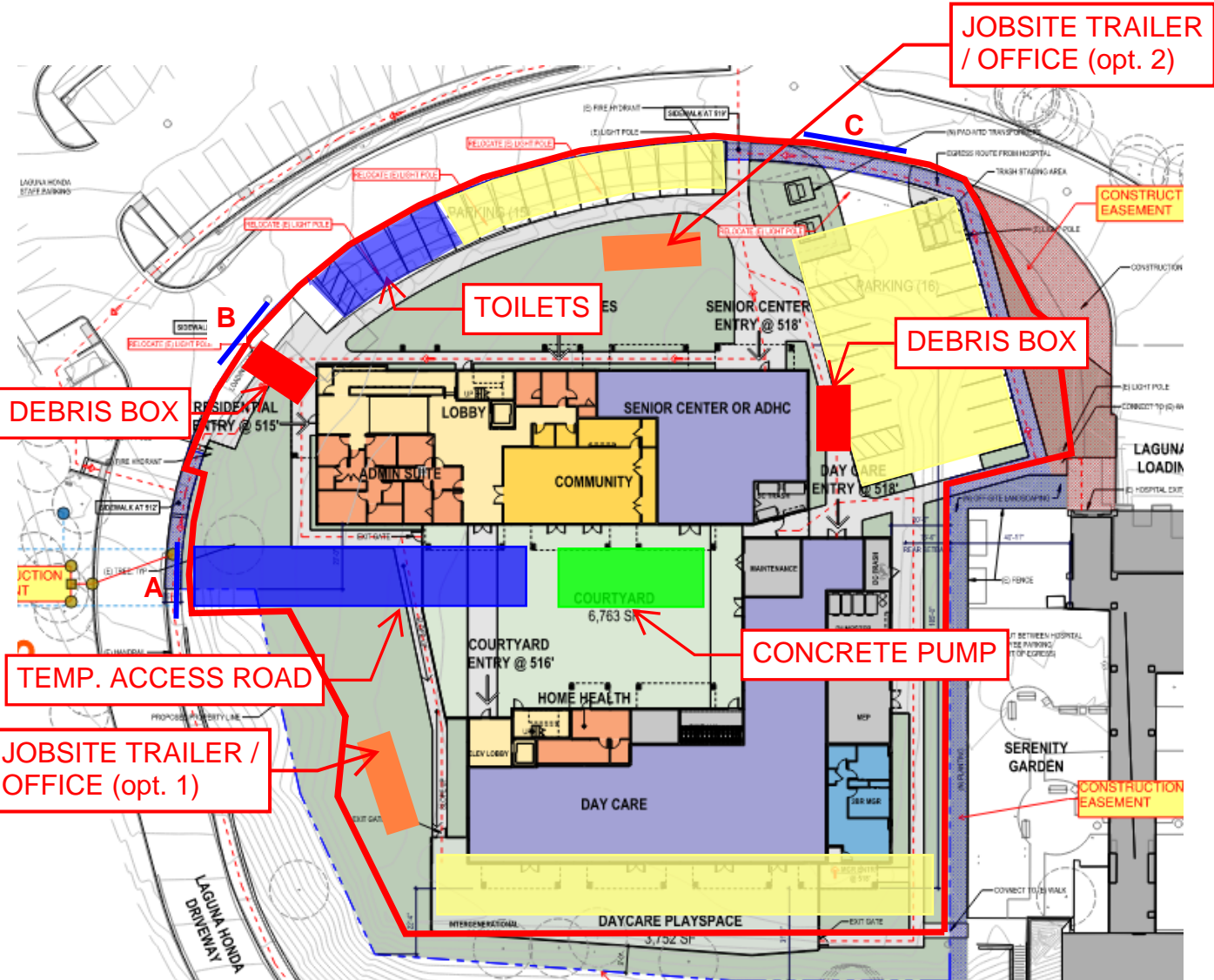

### Logistics Plan - Concrete

Approx. usage month 3 through month 7 (4 months)  
Typical working hours for all phases - 7:00am - 3:30pm

Subcontractor Laydown / Storage / Offices

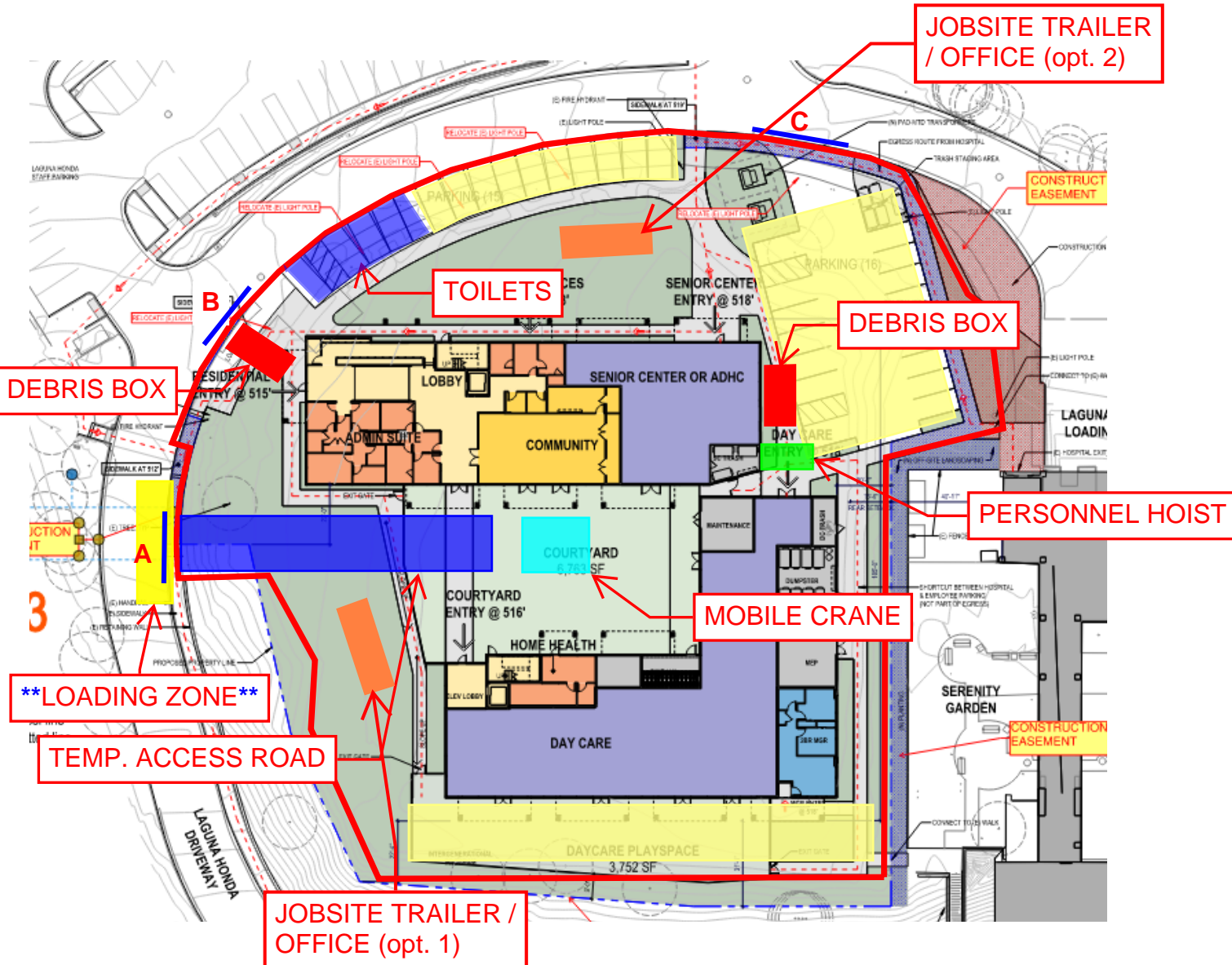

### Logistics Plan - Framing & Finishes

Approx. usage starting month 8 through month 22 (14 months)  
Typical working hours for all phases - 7:00am - 3:30pm

 Subcontractor Laydown / Storage / Offices

\*\*Cahill will provide flaggers & traffic control during deliveries to ensure pedestrian and car safety at all times.