

# **FILLMORE PARK OWNERS' ASSOCIATION RULES AND REGULATIONS**

## **INTRODUCTION**

The Rules and Regulations adopted herein are intended as a guide to the conduct and activities of all members, tenants, residents, and their guests. Each owner or resident living within the building and using the facilities is entitled to maximum enjoyment of the premises without annoyance or interference from others, and without annoying or interfering with the rights of others.

## **CHANGES IN RULES AND REGULATIONS**

The Board of Directors (the "Board") may, alter, amend, revoke or add to these Rules and Regulations for the preservation of safety and order within the community, for its care and cleanliness and for the protection of the reputation thereof. When notice of any such alteration, amendment, revocation or addition is given to any owner or resident, it shall have the same force and effect as if originally made a part of the Rules and Regulations. Where approval or permission of the Board is required herein, such approval shall be in writing and formally approved by a majority vote of the Board.

Unit owners, including absentee unit owners, are responsible for ensuring that tenants and guests abide by the Rules and Regulations.

In the event of any contradiction between any of these Rules & Regulations and any provisions of the CC&Rs, the Articles, or Bylaws, the conflicting rule or regulation shall be superseded by the provisions of the CC&Rs, Articles, and the Bylaws.

## **VIOLATION OF RULES AND REGULATIONS**

Indications of or actual violations will be brought to the attention of the responsible owner (and tenant, if any) in writing by the property management company following the policies established by the Board. Failure of an owner to correct a violation could result in the owner being subject to a fine or special assessment. Further failure to correct the violation may cause legal action to be taken. All expenses incurred by the Association to address and resolve a violation will be the responsibility of the unit Owner responsible for the violation. Unit Owners are responsible for all violations caused by their tenants, guests, pets, and other household occupants.

## **USE RESTRICTIONS**

1. All condominium units shall be used for residential purposes only in conformance with the restrictions in the CC&Rs.

2. No trade or business shall be conducted in the condominiums other than for the purpose of operating a small home-based business to the extent allowed by local ordinance, but such business shall not allow customers or clients.

## **PETS**

1. Except as otherwise restricted below and in the CC&Rs, each unit is permitted one (1) dog, weight not in excess of 75 pounds, and two (2) birds or cats (maximum of three pets, excluding fish) provided such animals are not kept, bred or raised for commercial purposes. Board permission is required to keep any other type of pet. No pet shall be allowed on the premises that the Board determines to be a threat to the safety, welfare, quiet comfort or enjoyment of other residents. If the Board determines that a pet is a nuisance, annoyance or threat, the Board may require the pet to be removed from the premises or may impose such other mitigation requirements on the Owner to eliminate the nuisance, annoyance or threat.
2. Owners are required to inform the Association of the type and breed of each pet upon commencement of occupancy or within 10 days of move-in or acquisition of a new pet. The Association may request the Owner to provide proof of vaccinations. All cats and dogs must be spayed or neutered. **Pets are not allowed unless the applicable Pet Registration Forms have been completed.**
3. Pet owners agree to comply with:
  - a. The California State Health and Safety Code
  - b. All other applicable governmental laws and regulations, such as but not limited to licensing, vaccinations, leashing, sanitation, etc.
4. All dogs and cats must be restrained on a leash at all times in common areas and under no circumstances are they to be allowed to run free. Any pet found off-leash in the common area may be removed to a pound or animal shelter by calling the appropriate authorities. The Board, as well as every resident in the project, has the right to take such action.
5. If a person already in an elevator should object to the entry of an animal into the elevator, the animal and its handler/owner must wait for another elevator or take the stairs.
6. In no event shall any Owner authorize, bring or keep on the Property (a) any pit bull, rottweiler, doberman pinscher, mastiff, canaria press, or any other dog breed known as a "fighting breed" or mix thereof; or (b) any snakes, pigs, large lizards, spiders, rats or vermin.
7. The common areas shall not be used for relieving of pets' bodily functions. Any accidental defecation must immediately be removed and disposed of by the pet's owner. The cost of cleaning and deodorizing common areas due to pet "accidents" is the pet owner's obligation.
8. Damages to the common areas by pets shall be billed to the unit owner at the current replacement and/or repair cost, plus administrative expenses.
9. Pet owners are responsible for controlling the noise of their pets.

10. Pet owners are responsible for any personal injury or property damage caused by their pets.
11. Pets shall not be left unattended in any of the common areas, or on patios or balconies of a unit.
12. Residents shall not allow any visitor to bring a pet into the building. This rule does not apply to any animal used by a tenant or visitor that is needed as a reasonable accommodation for the tenant or visitor's disability (24 CFR Part 5 HUD regulations).
13. Exemption for Persons with Disabilities. Pursuant to State law [HUD ref 4350.30, 4-14 (b)], service animals that assist persons with disabilities are considered to be auxiliary aids and are exempt from the pet rules #4 through #12 noted herein, and from any refundable pet deposit. Examples include guide dogs for persons with vision impairments, hearing dogs for persons with hearing impairments, and emotional assistance animals for persons with chronic mental illness.
14. Stray Animals and Wild Birds. The feeding of stray animals and wild birds is strictly prohibited as they pose a health hazard and are a nuisance to the other owners.

#### **DOORS, GATES AND SECURITY**

1. All common area building entry doors, stair doors must remain locked at all times. This precaution must be taken in order to safeguard the private property of the Association and the residents.
2. Certain doors such as unit entry doors and stair doors must remain closed at all times when not in use in order to prevent the spread of fire in such an emergency. In addition, corridor fire doors and elevator doors which are held open by magnetic devices must not be obstructed or propped open by other means. These doors must be free to close automatically in the event of any emergency. Propping doors open or in any way interfering with the automatic locking mechanism of any door or gate when unattended, is prohibited. Any damage or loss resulting from such action shall be the financial responsibility of the person(s) performing such actions.
3. Sidewalks, entrances, passages, walkways and common areas must not be obstructed or used for any purpose other than entry to or exit from the premises.
4. Plants, planters, floor mats or other stand-alone items in or around the corridor entrance of individual units require approval of the Board of Directors.

#### **SIGNAGE AND DECORATIONS FOR RESIDENTIAL UNITS**

1. No signage or decorative items of any kind may be affixed to the unit entry doors. All placards, signage or decorations adjacent to unit entry doors must be approved by the Board

prior to display. All placards or postings must be compliant with applicable Federal, State, and local laws, regulations and policies. Any damage to the common area finishes caused by the temporary mounting of such placards, signage or decorations, shall be repaired at the expense of the owner.

2. No decorations, displays, or holiday lighting shall be affixed to the exterior of the building without the prior approval of the Board.

### **SMOKING**

1. There is NO SMOKING allowed anywhere in the common area of the project, including but not limited to the elevators, hallways, stairwells, lobbies, storage, utility rooms, balconies, patios, or other interior or exterior common areas of the complex, including the area in front of the main entrance. The Board is authorized to impose fines on Owners for violations of this restriction.
2. Smoking is permitted within the confines of individual units, provided that smoke is prevented from migrating into the common area or other units in the building and creating an annoyance to other residents. Smokers are encouraged to turn on bath and kitchen exhaust fans in order to keep smoke from spreading to adjacent units and the common areas.

### **BUILDING ACCESS**

1. The main entry, elevators, and other building entry doors are key controlled for security purposes. Do not loan your building access key to vendors, delivery personnel or home service providers. If you have regular home services (i.e. cleaning service, personal health care service, etc.) you should purchase special keys for such personnel from the property manager for \$25 per key.

### **ELEVATORS**

1. In case of an elevator malfunction, the elevator is equipped with a telephone that can be used to ring directly to the Elevator Emergency Service which is on-call 24-hours per day. Remain calm, press the phone button, and respond to the operator's questions. This phone is for emergency use only.
2. Owners are responsible for protecting the elevators when transporting any materials, furniture, or pets. Wall pads and floor protectors are available from the property manager.

### **DISTURBING NOISES AND NUISANCES**

1. Residents are entitled to the quiet enjoyment of their homes. The close proximity of living areas and common walls dictates that common sense, good judgment and consideration should be used by residents and their guests at all times. Any activity which, by its nature,

violates or has the potential to violate the right to quiet enjoyment by other residents shall be deemed a violation of these Rules and Regulations.

2. No speakers shall be affixed to any wall, ceiling, shelving or cabinet so as to cause vibrations discernible between the units or within the common area. Speakers shall be elevated from the floor by proper acoustic platforms.
3. No person shall produce noise or vibrations of any kind at such levels as will be discernable and offensive to other owners or residents.
4. No running, jumping, stomping, yelling, or loud conversation in the common areas or creating any other noise or nuisance is allowed.
5. No non-motorized wheeled recreational vehicles shall be operated or stored in the common area hallways, lobbies, or other common areas except as stated herein or as approved by the Board. For the purposes of this paragraph, wheeled recreational vehicles include but are not limited to bicycles, tricycles, wagons, scooters, skateboards, roller skates, in-line skates or similar devices. Such vehicles may only be stored within individual units or in designated storage areas. When transporting such vehicles through the common area, they must be carried to the extent practical, or rolled but not ridden. The owner/operator shall be responsible for any damage or personal injury caused by the transport of such vehicles through the common area.
6. No person(s) shall discharge into the building's sewer system or storm drain any toxic or noxious matter in such concentrations as to be detrimental to or endanger the public health, safety, welfare, violate any law, subject any owner, resident or the Association to liability under state or federal law for clean-up, or cause injury or damage to neighboring property or businesses.
7. No odor shall be emitted from a unit or into the common area in such quantity as to be readily detectable outside the boundaries of the unit within which such odor was generated. This restriction applies, but is not limited to, smoking, cooking, and pet odors.
8. No air pollutants or contaminants sufficient to create a nuisance shall be discharged, and no processes which by their nature are likely to cause air pollution shall be undertaken or permitted unless there is available an adequate, economically feasible method of controlling the emission of contaminants, and such controls are approved by the Board.

### **MOVING IN & OUT**

1. Move-ins/outs after the initial occupancy are only allowed between the hours of 9 a.m. and 8 p.m., Monday through Saturday. Moves and/or large deliveries are not allowed on Sundays or Holidays, except during initial occupancy move-ins.
2. Choose your moving company carefully. You are responsible and must reimburse the Association for damage to the common area incurred during your move. It is important that

your moving company carries their own insurance for such damage and provides appropriate protection. Proof of insurance will be required by the property manager.

3. There is a fee of \$125.00 each for moving in and moving out. This is an administrative fee to cover the costs of hanging and removing pads in the elevator, changing mailbox signage, updating the directory board and changing residency records for the unit. This is a non refundable fee to be paid to the association directly by the resident that is either moving in or moving out.

### **MAIL & PACKAGE DELIVERIES**

1. Mailbox and mailbox area are to be kept free of litter, signage, markings, or overflow of mail.
2. Resident is responsible for the upkeep of their personal mailbox and mailbox lock maintenance. Management does not hold keys to your mail box so any replacement keys or repairs to the lock are the responsibility of the unit owner.
3. Deliveries of large items, such as furniture or appliances must be coordinated through management in order to schedule and place protective coverings in the elevator and appropriate common areas. Fees for placement of protective coverings will apply.
4. Liability of Association – The Association shall bear no responsibility for any articles delivered to or left with any employee of the Association or Management Company. Further, the Association shall not be responsible for any article intended for delivery to a resident, delivered or left in any corridor or public place. No bailment is expressed or implied in such instances.

### **VENDORS, TRADESMEN & SERVICE PROVIDERS**

1. Residents desiring tradesmen, vendors or service providers to enter their unit must be present during such visits. Management will not be responsible to let tradesmen or others into a unit during the Resident's absence.
2. For regularly scheduled service providers (i.e. cleaning service, pet sitters, tutors, meal providers, etc.) special building access keys can be provided at a nominal charge. These keys can be used to provide limited building access restricted to specific times and days of the week. Please contact the property manager who must have these service providers names and phone numbers in advance.
3. Owner is responsible for obtaining insurance from its vendors, tradesmen and service providers as required.

### **GARBAGE AND REFUSE DISPOSAL**

1. All household garbage must be bagged in leak proof containers. This is required to protect common areas and to keep the trash area clean. Secured bags are the only permissible trash containers.
4. Residents are responsible for disposal of volatile or flammable materials, glass, pottery, and heavy objects. Special pick up of these items may be obtained by contacting the local refuse collection company. No portion of the common area will be used as a dumping ground for rubbish, trash, garbage or other refuse.
5. No trash compactors are permitted to be installed within the residential units as the compacted garbage can cause damage to trash equipment below.
6. In the event of damage to bags in the disposal process, residents are responsible for cleaning up their own trash spilled on common areas and disposing of it properly. Owners may be charged for special cleaning services provided by the Association.
7. Oversized items should not be left outside the trash area. No large items such as furniture or mattresses, or chemicals such as paint, insecticides, and motor oils, or electronic equipment are to be placed in the trash area. These items are the responsibility of the owners to dispose of at an appropriate disposal or recycling facility.
8. Biohazardous waste is not to be discarded along with regular trash. CalOSHA (CCR, Title 8 General Industry Safety Orders; and Subchapter 7 Group 16, Art. 109, #5193), categorizes certain wastes as biohazards and mandates special handling for disposal. If you have any trash that contains blood, body fluids, hypodermic needles, or any toxic chemicals, you must make arrangements to have this trash processed through a special vendor. A sharps container (for needles) may be ordered through your local pharmacy.

### **ARCHITECTURAL/EXTERIOR APPEARANCE**

1. To maintain a uniform outward appearance of the building, owners are limited to installing blinds or drapes with a white or off-white appearance when viewed from the outside. Colors may be used provided they are lined on the back with a white or off-white lining or secondary shear. Non-conforming window coverings are subject to review by the Board and may be required to be removed or modified.
2. Patios, balconies and entrances to the units are to be kept clean and free of debris. No unsightly conditions will be permitted.
3. No exterior installation of radio poles, sun-shades, flag poles, glass tinting (whether inside or outside the glass), clotheslines, air conditioning units or other fixtures will be permitted to be affixed to the building exterior or otherwise made visible from the building exterior, without the permission of the Board. The owner shall be responsible for all wiring and installation costs for its satellite dish(es).

4. No balcony, patio or deck covers, wiring, water softeners, or other machines which are not part of the original building construction shall be permitted nor shall they be allowed to protrude through the walls or roofs of the building.
5. Any penetration into any wall, ceiling or floor beyond one-half inch may damage utilities, structural components or acoustical properties of those assemblies. There shall be no wall ceiling or floor penetrations of any type (including picture hangers) of more than one-half inch into the drywall except where otherwise approved by the Board.
6. All exterior and common area painting and caulking is the responsibility of the Association. If paint or caulking requires maintenance or repair, please report it to the property manager immediately.

### **FLOOR COVERING AND ACOUSTICAL RESTRICTIONS**

1. All flooring work must comply with the “Noise Insulation Standards” of the California Administrative Code (Title 24), and the San Francisco Building Code and IBC.
2. The Board must approve all hardwood, stone, tile, or other hard surface flooring installations and shall have the right to request acoustical testing at the expense of the owner. Otherwise, the Owner will be required to implement additional acoustical measures which may include removal and/or reinstallation of the flooring.
3. Prior to installation, the flooring contractor must provide proof that the flooring material selected (wood, tile, marble, etc.) in combination with the underlayment chosen meets or exceeds the above requirements.

### **BALCONIES/DECKS/PATIOS**

1. No items may be stored on balconies, decks or patios except:
  - a. Potted plants in appropriate receptacles. Potted plants shall not be allowed to leak onto balconies or other portions of the building, neighboring units, or the sidewalk below.
2. Balconies, decks and patios may not be used for beating rugs or carpets, shaking dust mops, nor may any article be draped over the railings. No clothesline or other outside clothes drying or airing shall be done on any balcony or in any common area.
3. Balconies, decks and patios may not be used as holding areas for pets. No owner shall place or build any doghouse, shed, fence or other structure on a balcony or patio.
4. The balconies, decks and patios are exclusive use common areas. No other coating, tile, stone, pavers or any other surface other than that originally provided shall be affixed to the balcony surface. Any damage to this exclusive use common area resulting from the owner's installation of any material to the balcony shall be the responsibility of that owner.

### **LANDSCAPING**

1. The Association may employ a landscaping company whose duties are to maintain the landscaping and irrigation sprinklers. No homeowner or resident may make any alterations or improvements to the common areas or remove or modify any common area planting, structure, irrigation, or other feature without the approval of the Board.
2. Any damage, removal or other destruction of landscaping by any owner, resident or invitee shall be the financial responsibility of that owner.

### **BARBEQUES**

1. The use of individual outdoor barbeque grills is not permitted on the premises. Barbeques may not be stored or used on balconies, patios, or in the courtyards. A common area gas grill has been provided for use of all residents of the complex and that grill and its designated grilling area is the only place where outdoor grilling is permitted and only in compliance with the posted grilling regulations.

### **GENERAL RULES AND REGULATIONS**

1. Units have plumbing drainage systems in common. You may be liable for plumbing overflow damages in adjacent units if your unit is the origin of a back-up or flood. To avoid plumbing clogs, do not put potato peels, carrot peels, onion peels, artichokes, asparagus, other fibrous materials, dirt (from container gardening etc.), feminine hygiene products, diapers, or any other similar matter down toilets or plumbing fixture drains.
2. Patios/balconies, although designated for the exclusive use of an owner, are common areas and are not to be altered, painted, enclosed, etc.
3. Bathtub Jacuzzis or Spas – In order to preserve the structural integrity of the project as a whole, and to facilitate quiet enjoyment by all occupants of the building, the installation of bathtub Jacuzzis or spas is prohibited. Additionally, no hot tubs or similar devices shall be installed within any unit, balcony or patio.
4. Waterbeds -- Waterbeds and other similarly water-filled furniture are not allowed in any unit.
5. Loitering -- The common areas are designed for use by those residents who live in the complex. Please do not allow anyone to play in common areas or wander around the building unescorted. If you see anyone in the common areas who does not belong, please contact the Police Department immediately.
6. Solicitation – No advertising, pamphlets, or other printed solicitations of any kind shall be permitted to be distributed in the common areas, to residents' homes, in entranceways, halls, or elevator lobbies, except as approved by the Board. No soliciting, peddling or door-to-door canvassing of any nature whatsoever shall be permitted in the building or at any place around the property. Delivery of paid newspaper subscriptions and Association material is permitted.

7. Postings -- Posting of signs/notices is not permitted at any time in the common areas of the complex.
8. In case of continued or flagrant violations of the CC&Rs or these Rules & Regulations, the Board may impose monetary penalties, suspend use of facilities and/or seek legal remedies in court at the Owner's expense.
9. Parking Spaces. Parking spaces are restricted to the parking of one (1) automobile or motorized cycle per parking space. No parking area shall be used for storage or trash of any kind. Bicycles shall be stored only in storage spaces designated as bicycle storage areas.
10. Appliance Replacement. Although not a certified green building, there are green elements to the buildings construction that should be maintained. When replacing appliances, i.e., stoves, refrigerators, dishwashers, washers and dryers, they must be Energy Star rated.
11. Window Coverings. All drapes or curtains visible from the street or Common Area shall be white or off-white, except with the written consent of the Architectural Control Committee. Only curtains, shades or blinds shall be used a window coverings. No paper, cardboard, aluminum foil or other things may be used as window coverings.

- END -

RECORDING REQUESTED BY  
 AND WHEN RECORDED MAIL TO:  
 M. Brett Gladstone, Esq.  
 Gladstone & Associates  
 Attorneys at Law  
 Penthouse, 177 Post Street  
 San Francisco, CA 94108

This is to certify that this is a true and correct copy of the original document recorded on 4-20-12 at 9:00 AM as No. 12-J397256 in the County of San Francisco  
 Old Republic Title Company  
 By [Signature]

Block 0756, Lots 19, thru 50, inclusive

022TDD7131A-HK

**DECLARATION OF COVENANTS, CONDITIONS AND RESTRICTIONS  
 FILLMORE PARK, A 32-UNIT RESIDENTIAL  
 CONDOMINIUM PROJECT**

**ARTICLE I - DEFINITIONS ..... 6**

**ARTICLE II - DESCRIPTION OF PROJECT, DIVISION OF PROPERTY AND CREATION OF PROPERTY RIGHTS ..... 8**

SECTION 1. PROPERTY SUBJECT TO DECLARATIONS: ..... 8

SECTION 2. PARTITION PROHIBITED: ..... 8

SECTION 3. COMMON AREA OWNERSHIP: ..... 8

SECTION 4. RESTRICTED (EXCLUSIVE USE) COMMON AREAS: ..... 9

**ARTICLE III – HOMEOWNERS’ ASSOCIATION, MEMBERSHIP AND VOTING RIGHTS ..... 9**

SECTION 1. ORGANIZATION: ..... 9

SECTION 2. MEMBERSHIP: ..... 9

SECTION 3. TRANSFERRED MEMBERSHIP: ..... 10

SECTION 4. VOTING CLASSES: ..... 10

SECTION 5. VOTING PROCEDURES AND MEETINGS: ..... 10

SECTION 6. BOARD OF DIRECTORS: ..... 10

**ARTICLE IV - DUTIES AND POWERS OF THE ASSOCIATION ..... 11**

SECTION 1. DUTIES: ..... 11

*Subsection 1.1 Maintenance:* ..... 11

*Subsection 1.2 Repair and Maintenance of Common Area Damaged by Wood-Destroying Pests:* .... 11

*Subsection 1.3 Insurance:* ..... 12

*Subsection 1.4 Discharge of Liens:* ..... 16

*Subsection 1.5 Assessments:* ..... 16

*Subsection 1.6 Payment of Expenses:* ..... 16

*Subsection 1.7 Enforcement:* ..... 16

*Subsection 1.8 Budget and Annual Report:* ..... 16

*Subsection 1.9 Documents to be provided to Prospective Purchaser:* ..... 16

*Subsection 1.10 Following Maintenance Guidelines:* ..... 16

SECTION 2. POWERS: ..... 23

*Subsection 2.1 Easements:* ..... 23

*Subsection 2.2 Access:* ..... 23

*Subsection 2.3 Manager:* ..... 23

*Subsection 2.4 Association Rules:* ..... 23

*Subsection 2.6 Enforcement of Rules and Restrictions:* ..... 25

*Subsection 2.7 Acquisition of Property:* ..... 26

<i>Subsection 2.8 Loans:</i> .....	26
<i>Subsection 2.9 Dedication:</i> .....	26
<i>Subsection 2.10 Contracts:</i> .....	26
<i>Subsection 2.11 Delegation:</i> .....	26
<i>Subsection 2.12 Litigation/Alternative Dispute Resolution:</i> .....	26
<i>Subsection 2.13 Power of Attorney:</i> .....	27
<b>ARTICLE V - ASSESSMENTS</b> .....	<b>27</b>
SECTION 1. COVENANTS FOR MAINTENANCE ASSESSMENTS: .....	27
SECTION 2. REGULAR MONTHLY ASSESSMENTS: .....	28
SECTION 3. SPECIAL ASSESSMENTS: .....	30
SECTION 4. REIMBURSEMENT CHARGES: .....	31
SECTION 5. NON-WAIVER OF ASSESSMENTS: .....	31
SECTION 6. ENFORCEMENT: .....	31
<i>Subsection 6.1 Demand Letter:</i> .....	32
<i>Subsection 6.2 Claims Within the Jurisdiction of Small Claims Court. (Currently \$7, 500 or less):</i> ..	34
<i>Subsection 6.3 Enforcement by Lien:</i> .....	34
<i>Subsection 6.4 Enforcement by Suit for Claims Above \$7, 500</i> .....	36
SECTION 7. POWER OF FORECLOSURE AND SALE: .....	36
SECTION 8. TRANSFER OF UNIT BY SALE OR FORECLOSURE: .....	36
SECTION 9. RELEASE OF LIEN: .....	37
SECTION 10. STATUS OF ASSESSMENT LIEN: .....	37
SECTION 11. SUBORDINATION OF LIEN TO ENCUMBRANCE: .....	37
SECTION 12. ASSOCIATION FUNDS: .....	37
SECTION 13. BOOKS OF ACCOUNT: .....	38
<b>ARTICLE VI - EASEMENTS</b> .....	<b>38</b>
SECTION 1. GENERALLY: .....	38
SECTION 2. EASEMENTS FOR UTILITIES AND MAINTENANCE: .....	38
SECTION 3. INGRESS AND EGRESS: .....	39
SECTION 4. DECK AREAS: .....	39
<b>ARTICLE VII - USE RESTRICTIONS</b> .....	<b>39</b>
SECTION 1.1. RESIDENTIAL CONDOMINIUM USE: .....	40
SECTION 3. NUISANCES: .....	40
SECTION 4. VEHICLE RESTRICTIONS: .....	40
SECTION 4.2. HANDICAPPED PARKING: .....	41
SECTION 5. SIGNS: .....	42
SECTION 6. ANIMALS: .....	42
SECTION 7. GARBAGE AND REFUSE DISPOSAL: .....	43
SECTION 8. RADIO AND TELEVISION ANTENNAS AND SATELLITE DISHES: .....	43
SECTION 9. NO RIGHT TO LEASE: .....	43
SECTION 10. CLOTHES LINES: .....	43
SECTION 11. POWER EQUIPMENT AND CAR MAINTENANCE: .....	43
SECTION 12. LIABILITY OF OWNERS FOR DAMAGE TO COMMON AREA: .....	43
SECTION 13. CURTAINS OR DRAPES: .....	44
SECTION 14. WALL PENETRATIONS: .....	44
SECTION 16. COOK TOPS: .....	44
SECTION 17. DECK RESTRICTIONS: .....	44
SECTION 18. AIR VENTILATION: .....	44
SECTION 19. LOW-FLOW TOILETS: .....	45
SECTION 20. NOISE RESTRICTIONS: .....	45
SECTION 21. SMOKING RESTRICTIONS: .....	45
SECTION 22. EXTERIOR PENETRATIONS: .....	45
<b>ARTICLE VIII - ARCHITECTURAL CONTROL</b> .....	<b>45</b>
SECTION 1. COMMITTEE PURPOSE AND SIZE: .....	45
SECTION 2. APPOINTMENT, REMOVAL AND TERM OF OFFICE: .....	45

SECTION 3. DUTIES:.....	46
SECTION 4. MEETINGS:.....	46
SECTION 5. APPLICATION FOR APPROVAL OF IMPROVEMENTS:.....	46
SECTION 6. BASIS FOR APPROVAL:.....	46
SECTION 7. APPROVAL:.....	47
SECTION 8. LIABILITY:.....	47
<b>ARTICLE IX - MORTGAGEE RIGHTS AND PROTECTION.....</b>	<b>47</b>
SECTION 1. MORTGAGE PERMITTED:.....	47
SECTION 2. SUBORDINATION:.....	47
SECTION 3. AMENDMENT:.....	48
SECTION 4. RIGHTS OF MORTGAGEES:.....	48
SECTION 5. CONSENT TO ACTION:.....	49
SECTION 6. DISTRIBUTION OF INSURANCE AND CONDEMNATION PROCEEDS:.....	50
SECTION 7. NOTICES TO MORTGAGEES OF RECORD:.....	50
<b>ARTICLE X - DAMAGE, DESTRUCTION OR CONDEMNATION OF COMMON AREA IMPROVEMENTS.....</b>	<b>51</b>
SECTION 1. DAMAGE AND DESTRUCTION:.....	51
<i>Subsection 1.1 Insured Losses:</i> .....	51
<i>Subsection 1.2 Uninsured or Insufficiently Insured Losses:</i> .....	51
<i>Subsection 1.3 Full Insurance Settlement:</i> .....	52
<i>Subsection 1.4 Emergency Repairs:</i> .....	52
<i>Subsection 1.5 Decision Not to Rebuild:</i> .....	52
SECTION 2. DISTRIBUTION OF FUNDS IN EVENT OF CONDEMNATION:.....	52
<b>ARTICLE XI - GENERAL PROVISIONS.....</b>	<b>52</b>
SECTION 1. ENFORCEMENT OF BONDED OBLIGATIONS:.....	52
SECTION 2. INVALIDITY OF ANY PROVISION:.....	53
SECTION 3. TERM:.....	53
SECTION 4. AMENDMENTS:.....	53
SECTION 6. ENFORCEMENT:.....	54
SECTION 7. ALTERNATIVE DISPUTE RESOLUTION:.....	54
<i>(a) Mediation:</i> .....	55
<i>(b) Arbitration of Disputes:</i> .....	55
SECTION 8. CLAIMS UNDER \$7,500 AND COURT ACTIONS FOR INJUNCTIVE OR DECLARATORY RELIEF:.....	56
SECTION 9. NOTICE OF CIVIL ACTIONS; MEETING:.....	57
SECTION 10. [INTENTIONALLY DELETED].....	57
SECTION 11. ALTERNATIVE DISPUTE RESOLUTION:.....	57
<i>(a) MEDIATION:</i> .....	58
<i>(b) ARBITRATION OF DISPUTES:</i> .....	58
SECTION 12. CLAIMS UNDER \$7,500 AND COURT ACTIONS FOR INJUNCTIVE OR DECLARATORY RELIEF:.....	59
SECTION 13. NOTICE OF CIVIL ACTIONS; MEETING:.....	60
SECTION 14. ALTERNATIVE DISPUTE RESOLUTION INVOLVING CLAIMS BETWEEN THE ASSOCIATION AND THE DECLARANT AND ANY OWNER:.....	61
<i>Subsection 14.1 Waiver of a Trial By a Jury:</i> .....	61
<i>Subsection 14.2 Nonadversarial Prelitigation Procedures:</i> .....	62
<i>Subsection 14.3 Binding Adversarial Procedures:</i> .....	63
<i>Subsection 14.4 Agent for Services of Claim Notice:</i> .....	65
<i>Subsection 14.5 Documents and Subsequent Owners:</i> .....	66
<i>Subsection 14.6 Covenants:</i> .....	66
<i>Subsection 14.7 Amendments:</i> .....	66
<i>Subsection 14.8 Claims Filing Period:</i> .....	67
<b>ACKNOWLEDGEMENT EXHIBIT A.....</b>	<b>67</b>
<b>EXHIBIT B.....</b>	<b>69</b>
<b>CONDOMINIUM PLAN.....</b>	<b>69</b>

EXHIBIT C .....	70
<u>UNIT NUMBER</u> <u>PERCENTAGE</u> .....	70
EXHIBIT D .....	71
UNIT MAINTENANCE AND REPAIR RESPONSIBILITIES.....	71
EXHIBIT E .....	72
FORM OF LIMITED EQUITY HOME OWNERSHIP PROGRAM DECLARATION OF RESTRICTIONS FOR FOR-SALE AFFORDABLE HOUSING UNITS AND OPTION TO PURCHASE AGREEMENT .....	72

THIS DECLARATION is made on the date hereinafter set forth by MSPDI TURK, LLC, a wholly-owned subsidiary of Michael Simmons Property Development, Inc., a California corporation (hereinafter collectively called "Declarant" or "Grantor").

Recitals

This Declaration is made with respect to the following facts:

- A. Declarant is the owner of the fee estate in and to the land and improvements described as 1345 Turk Street, Block 0756, Lot 017 (formerly portion of Lot 001) in the City of San Francisco, State of California (the "Property").
- B. Declarant is constructing a condominium development (the "Project") consisting of 32 residential units, more particularly described on the subdivision map entitled "Final Map No. 5914, a 32 Unit Residential Condominium Project", which Map was filed for record in the City and County of San Francisco on November 22, 2011, in Book 117 of Condominium Maps at Pages 51 through 53 inclusive.
- C. Declarant intends to establish separate interests in the Property as Condominiums under the provisions of the Davis Sterling Act.
- D. Declarant hereby establishes by this Declaration a plan for ownership of separate real property estates in the Property, consisting of the airspace contained in each Unit, and a co-ownership interest as a tenant-in-common with the other individual Owners of the remaining portions of the Property, which portions are hereinafter defined and referred to as the "Common Area."
- E. It is Grantor's intention to impose upon such property mutually beneficial restrictions under a general plan of improvement for the benefit of all of said condominiums and the owners thereof; and
- F. Grantor hereby establishes by this Declaration a plan for the individual ownership of the real property estates, consisting of the area of space contained in each Unit as well as the co-ownership by the individual owners of the Common Area.

NOW THEREFORE, Grantor hereby declares that the Property is held and shall be held, conveyed, hypothecated, encumbered, leased, rented, used, occupied and improved, subject to the following limitations, restrictions, covenants and conditions, all of which are declared and agreed to be in furtherance of a plan for the improvement of the Property and the division thereof into condominiums and are established and agreed upon for the purpose of enhancing and perfecting the value, desirability and attractiveness of the Property and every part thereof. All of the limitations, covenants, restrictions, and conditions shall run with the Property and shall be binding upon all parties having or acquiring any right, title, or interest therein or any part thereof, and shall be for the benefit of each owner of any portion of the Property or any interest therein, and shall inure to the benefit of and be binding upon each successor in interest.

## ARTICLE I - DEFINITIONS

“Architectural Control Committee” shall have the meaning set forth in Article VIII, Section 1 below.

“Articles” shall mean the Articles of Incorporation Fillmore Park Homeowners’ Association, a non-profit mutual benefit corporation.

“Assessment” means any regular or special Assessment made or assessed by the Association against an Owner and his or her Condominium according to the provisions of Article V of this Declaration.

The “Association” means Fillmore Park Homeowners’ Association, a non-profit mutual benefit corporation, membership in which shall be limited to Owners (as hereinafter defined) of Condominiums (as hereinafter defined) and in which all such Owners have a membership interest.

“Beneficiary” means and refers to a mortgagee under a mortgage or a beneficiary under a deed of trust encumbering a Unit.

“Board” or “Board of Directors” means the governing body of the Association.

“By-Laws” means the By-Laws of the Association which are or shall be adopted by the Board.

“Common Area” consists of the entire property except for the units.

“Condominium” means an estate in real property as defined in California Civil Code Section 1351(f) consisting of an undivided interest in a Common Area together with an interest in a Unit including certain easements appurtenant to such Unit. For the purpose of this Declaration, the ownership of each Condominium includes a Unit together with the easements appurtenant to such Unit, the respective undivided interests in Common Area (based on each Unit’s Percentage Interest In Common Area) and a membership in the Association (as defined above).

“Condominium Plan” shall mean the condominium plan for the Property that was prepared in accordance with the requirements of Civil Code Section 1351(e) and that is attached as Exhibit B to this Declaration.

“Declarant” means and refers to the party mentioned in the first paragraph of page 1 of this document, and all successors and assigns of Declarant, if such successors and assigns acquire more than one Unit for the purpose of resale to another.

“Declaration” means and refers to the within Declaration of Covenants, Conditions and Restrictions Establishing a Plan for Condominium Ownership of Fillmore Park.

“Director” means and refers to a member of the Board of Directors.

“Eligible Mortgage Holder” means and refers to those holders of a first mortgage on a unit estate who have requested the Association to notify them on any proposed action that requires the consent of a specified percentage of eligible mortgage holders.

“Final Public Report” means the subdivision public report issued by the Department of Real Estate of the State of California which shall allow Declarant to sell one or more Condominiums in the Property.

“Governing Documents” mean the Articles, Bylaws, this Declaration, and the Rules adopted by the Association.

“Manager” shall have the meaning set forth in Article IV, subsection 2.3 below.

“Map” shall mean the subdivision map referenced in Recital B above.

“Member” means and refers to those unit owners who are members of the Association pursuant to Article III hereof.

“Mortgage” means a deed of trust as well as a mortgage.

“Mortgagee” means a beneficiary under or holder of a deed of trust as well as a mortgage.

“Owner” or “Owners” mean the holder or holders of record of fee title to a Condominium, and a contract vendee of a Condominium, including Grantor.

“Percentage Interest In Common Area” means the percentages assigned to each Unit as set forth in Exhibit C hereto.

“Plan” shall have the same meaning as “Condominium Plan.”

“Property” shall have the meaning set forth in Recital A above.

“Residential Units” or “Residential Parcels” shall mean Units with that designation shown on the “Condominium Plan”.

“Restricted (Exclusive Use) Common Area” means and refers to those portions of the Common Area set aside for exclusive use of an Owner or Owners, as hereinafter set forth in Article II, Section 4 of this Declaration. This term shall have the same meaning as “Exclusive Use Common Area” as defined in Civil Code Section 1351(i).

“Rules” means the rules and/or regulations applying to residential uses adopted by the Association pursuant to this Declaration.

“Unit” shall mean the areas defined as a “Unit” in General Note No. 2 of the Condominium Plan.

The common boundary line between Units shall be a single line separating the adjacent Units with an easement equally distant on each side of said line for the purpose of a partition wall. The unit line for Units adjacent to the Common Area and to the exterior building lines is the unfinished interior surfaces of the wall of the Units. The lower limit is the top of the sub floor and the upper limit is the interior face of the ceiling.

Each Unit is subject to such encroachments as are contained in the Property, whether the same now exist or may be later caused or created in any manner referred to in Article VI of this Declaration. In interpreting deeds and plans, the then existing physical boundaries of a Unit, whether in its original state or reconstructed in substantial accordance with the original plans thereof will be conclusively presumed to be its boundaries rather than the boundaries expressed in the deed or the Plan, regardless of settling or lateral movement of the Property and regardless of minor variance between boundaries shown on the Plan or the deed and those of the Property.

## **ARTICLE II - DESCRIPTION OF PROJECT, DIVISION OF PROPERTY AND CREATION OF PROPERTY RIGHTS**

### **Section 1. Property Subject to Declarations:**

All of the real property shown on the Map as part of the Property is hereby declared to be subject to this Declaration and shall also be subject to the "Form of Limited Equity Home Ownership Program Declaration of Restrictions For-Sale Affordable Housing Units and Option to Purchase Agreement," attached hereto as Exhibit E and incorporated by this reference.

### **Section 2. Partition Prohibited:**

The Common Area will remain undivided as set forth above. Except as provided by California Civil Code Section 1359, no Owner shall bring any action for partition. It is agreed that this restriction is necessary in order to preserve the rights of the Owners regarding the operation and management of the Property. Judicial partition by sale of a single Unit owned by two or more persons and division of the sale proceeds is not prohibited hereby but physical partition of a single Unit is prohibited.

### **Section 3. Common Area Ownership:**

There will be conveyed with each respective Unit an undivided interest in the Common Area in the percentages set forth on Exhibit C hereto. The undivided interest in the Common Area to be conveyed with the respective Units cannot be changed, and the Declarant, its successors, assigns and grantees covenant and agree that the undivided interests in the Common Area, and the fee title to the respective Units conveyed therewith, will not be separated or separately conveyed, and each such undivided interest is to be deemed conveyed or encumbered with its respective Unit even though the description in the instrument of conveyance or encumbrance may refer only to the fee title to the Unit.

Each Residential Unit and each Residential Owner will share the expense of the Common Area pro-rated on the basis of Percentage Interest In Common Area. Each Owner of a Residential Unit shall be provided water and sewer services through the San Francisco Public Utilities Commission.

#### **Section 4. Restricted (Exclusive Use) Common Areas:**

Certain Restricted (Exclusive Use) Common Areas are hereby set aside and allocated for the exclusive use of the owner of the Unit to which they are assigned by Unit designation on the Plan and/or by grant deed from Declarant.

Restricted (Exclusive Use) Common Areas shall also consist of the exclusive easement to use the deck area specifically designated on the Plan as "D-" followed by the number of the adjoining Unit to which it is deeded.

Where a Restricted (Exclusive Use) Common Area has not been assigned by notation on the Plan, Declarant shall permanently assign the exclusive use of such Restricted (Exclusive Use) Common Area to particular Units upon conveyance of such Units, which assignments shall become an irrevocable portion of the ownership interest in the Unit to which assigned by Declarant.

Notwithstanding any other provision in this Declaration, the internal and external telephone wiring designed to serve a separate Unit are Restricted (Exclusive Use) Common Areas allocated exclusively to that particular Unit.

A Unit Owner shall be entitled to reasonable access to the Common Area for the purpose of maintaining the internal and external telephone wiring and cabling made part of a Restricted (Exclusive Use) Common Area pursuant to this section. Such access shall be subject to the consent of the Board of Directors of the Association, whose approval shall not be unreasonably withheld, and which may include the Board's approval of telephone wiring upon the exterior of the Common Area, and other conditions as the Board determines reasonable.

### **ARTICLE III – HOMEOWNERS' ASSOCIATION, MEMBERSHIP AND VOTING RIGHTS**

#### **Section 1. Organization:**

The Association is a non-profit mutual benefit corporation charged with the duties and empowered with the rights set forth herein and in the By-Laws and Articles of Incorporation. Its affairs shall be governed by this Declaration, the Articles, the By-Laws and the Rules of the Association. In the event that the Association as a corporate entity is dissolved, a non-profit, unincorporated association shall forthwith and without further action or notice be formed to succeed to all the rights and duties of the Association. The affairs of such unincorporated association will be governed by the laws of the State of California and, to the extent consistent therewith, by this Declaration, the Articles and the By-Laws of the Association as if they were created for the purpose of governing the affairs of an unincorporated association.

#### **Section 2. Membership:**

The Owner of a Unit shall automatically, upon taking title to a Unit, be a Member of the Association and shall remain a Member thereof until such time as his ownership ceases for any reason, at which time his membership in the Association will automatically cease. Membership is to be held in accordance with the Articles and By-Laws of the Association.



Members. Owners of Residential Units shall elect yearly three (3) members to the Board. Board shall hold office until the first regular meeting of the Members is held pursuant to the By-Laws. At said meeting, a new Board of three (3) Directors shall be elected to serve until the next regular annual meeting of the Members or until their successors are elected.

## **ARTICLE IV - DUTIES AND POWERS OF THE ASSOCIATION**

### **Section 1. Duties:**

In addition to the duties stated in its By-Laws and elsewhere in this Declaration, and without limiting the generality thereof, the Association shall perform the following duties:

#### **Subsection 1.1 Maintenance:**

The Association shall maintain, repair, replace, restore, operate and manage all of the Common Area and its facilities, improvements, furnishings, equipment and landscaping thereon.

Maintenance shall include (without limitation): painting, maintaining, repairing and replacing of all Common Area glass surfaces other than glass doors of Units, landscaping not lying upon the Restricted (Exclusive Use) Common Areas, and decks, storage areas, entry areas, mechanical rooms, recreation areas, elevators, roof and parking areas all of which are found in the Project. The Association shall not have responsibility to maintain items which are for the benefit of individual Units, and shall not have the responsibilities that are those of an Owner as listed in Exhibit D. The responsibility of the Association for maintenance and repair shall not extend to repairs or replacements arising out of or caused by the willful or negligent act or neglect of an Owner, or his guests, tenants or invitees, the cost of which is not covered by insurance.

The repair or replacement of a Unit interior or exterior resulting from such excluded items shall be the responsibility of each Owner. However, if an Owner fails to make the repairs or replacements which are the responsibility of such Owner, as provided above, then, upon a vote of a majority of the Board of Directors, and after not less than thirty (30) days notice to the Owner, and a hearing, the Association shall have the right, but not the obligation, to enter the Unit and make such repairs or replacements. The cost thereof shall be added to any amount due to the Association and shall be payable to the Association by the Owner of such Unit.

#### **Subsection 1.2 Repair and Maintenance of Common Area Damaged by Wood-Destroying Pests:**

The Association shall be responsible for repairing, replacing, or maintaining the Common Area, other than Restricted (Exclusive Use) Common Areas, regarding any damage caused by the presence of wood-destroying pests. This obligation shall not extend to damage by dry rot caused by any negligence of an Owner or occupant and not through wood-destroying pests.

Each Owner of a Unit shall bear the costs of any damage to his Unit caused by the presence of wood-destroying pests. However, by a majority vote of all Owners, such responsibility may be delegated to the Association which in turn may levy a special Assessment to recover such costs. In the event such a vote is taken, and the Association assumes responsibility for such maintenance and repair, the following shall apply:

The Association may cause the temporary summary removal of any occupant of a Unit for such periods and at such times as may be necessary for prompt, effective treatment of wood-destroying pests or organisms; and

The costs of temporary relocation during the repair and maintenance of the areas within the responsibility of the Association shall be borne by the individual Owner; and

The Association shall give notice of the need to temporarily vacate a Unit to the occupants and to the Owner(s), not less than fifteen (15) days nor more than thirty (30) days prior to the date of the temporary relocation. The notice shall state the reason for the temporary relocation, the date and time of the beginning of the treatment, the anticipated date and time of termination of treatment, and that the occupants will be responsible for their own accommodations during the temporary relocation; and

Notice by the Association shall be deemed complete upon either personal delivery of a copy of the notice to the occupants, and sending a copy of the notice to the Owners, if different than the occupants, by first-class mail, postage prepaid at the most current address shown on the books of the Association or by sending a copy of the notice to the occupants at the Unit address and a copy of the notice to the Owners, if different than the occupants, by first-class mail, postage prepaid, at the most current address shown on the books of the Association.

For purposes of the above sections, "occupant" means an Owner, resident, guest, invitee, tenant, lessee, sublessee, or other person in possession of the Unit.

### **Subsection 1.3 Insurance:**

The Association shall maintain a policy or policies of fire and casualty insurance, with extended coverage endorsement, for the full insurable value of the Units and the Common Area payable to the Association and held for the benefit of the Owners, the Mortgagees, the licensees and such other persons as their interests may appear, or such other fire and casualty insurance as the Board shall determine gives substantially equal or greater protection to the Owners, and their Mortgagees, as their respective interests may appear. Each policy shall provide that it shall not be canceled without at least thirty (30) days prior written notice to the Association and to each Unit Owner. Each such policy may be for a period of not to exceed three (3) years provided that the policy permits a short rate cancellation by the insured.

On an annual basis, the Board shall distribute to the members of the Association an insurance summary in conformance with Article V of the By-Laws. In addition, the Board shall review the limits of such insurance at least every other year, and shall increase or adjust the same if necessary to provide such adequate coverage and protection as is customarily carried by prudent property owners. Said policy or policies shall provide for a separate loss payable endorsement in favor of the mortgagees of each Condominium, if any.

The Association shall maintain a policy or policies of comprehensive public liability insurance in the amount of two million dollars (\$2,000,000) or more, insuring the Association, the Declarant, the Board, the Owners, and any Manager appointed as hereinafter provided against any liability to the public or to the Unit Owners incident to the ownership and/or use of the Project to protect against any liability to the public or to any Unit Owner incident to the use of, or resulting from any accident or intentional act occurring in or about, any Unit, or the

Common Area. The minimum limits of such insurance shall be established to provide such coverage and protection as is customarily carried by prudent owners of similar property and to meet the minimum amounts required by Civil Code Section 1365.9 or a comparable superseding statute. Each such policy may be for a period of not to exceed three (3) years, provided that the policy permits a short rate cancellation by the insured. The Board shall review the limits and coverage of such insurance at least every other year and shall increase or adjust the same, if necessary, to provide adequate coverage and protection to the Association, Board, Manager, if any, and Unit Owners. Said policy or policies shall provide a cross liability endorsement wherein the rights of a named insured thereunder shall not be prejudiced as respects any action by one insured thereunder against another named insured.

**a.** Named Insured: Unless otherwise provided in this Article, the named insured shall be the Association or its authorized representative, as a trustee for the Members. However, all policies shall be for the benefit of owners and their Mortgagees, as their interests may appear.

**b.** Certificate of Insurance: The Board shall give notice of the Association's insurance coverage in accordance with California Civil Code Section 1365(e), or any superseding statute. A summary of the Association's insurance policies shall be distributed within 60 days preceding the beginning of the fiscal year. The summary shall include the following:

- i.** The name of the insurer;
- ii.** The type of insurance;
- iii.** The policy limits of the insurance;
- iv.** The amount of deductibles, if any; and

**v.** The summary distributed pursuant to this paragraph shall contain, in at least 10-point boldface type, the following statement: This summary of the Association's policies of insurance provides only certain information, as required by subdivision (e) of Section 1365 of the Civil Code, and should not be considered a substitute for the complete policy terms and conditions contained in the actual policies of insurance. Any Association member may, upon request and provision of reasonable notice, review the Association's insurance policies and, upon request and payment of reasonable duplication charges, obtain copies of those policies. Although the Association maintains the policies of insurance specified in this summary, the Association's policies of insurance may not cover personal property or real property improvements to a Unit, or personal injuries or other losses that occur within or around a Unit. Even if a loss is covered, an Owner may nevertheless be responsible for paying all or a portion of any deductible that applies. Association members shall consult with their individual insurance broker or agent for appropriate additional coverage.

**c.** Authority to Negotiate: Exclusive authority to adjust losses under policies obtained by the Association shall be vested in the Board; provided, however, that no Mortgagee having an interest in such losses may be prohibited from participating in any settlement negotiations related thereto.

**d.** Contribution: In no event shall the insurance coverage obtained and maintained by the Association be brought into contribution with insurance purchased by Owners or their Mortgagees.

**e.** General Provisions: To the extent possible, the Board shall make every reasonable effort to secure insurance policies providing for the following:

- (i)** A waiver of subrogation by the insurer as to any claims against the Board, the Manager, the Owners and their respective servants, agents and guests;
- (ii)** A waiver by the insurer of its right to repair and reconstruct instead of paying cash;

(iii) That no policy may be canceled, invalidated or suspended on account of the acts of any one or more individual Owners;

(iv) That no policy may be canceled, invalidated or suspended on account of the conduct of any Manager, Director, officer or employee of the Association without prior demand in writing delivered to the Association requiring remedying of the defect and allowing a reasonable time within which the defect may be cured by the Association, its Manager, any Owner or Mortgagees;

(v) That any other insurance clause in any policy excludes individual Owners policies from consideration;

(vi) That no policy may be canceled or substantially modified without at least ten (10) days' prior written notice to the Association;

(vii) An agreed amount endorsement; and

(viii) An inflation guard endorsement.

f. Term: The period of each policy shall not exceed three (3) years, provided the policy permits short rate cancellation by the insured.

g. Annual Review: The Board shall review the adequacy of all insurance at least once every year. At least once every three years the review shall include a replacement cost appraisal of all insurable Common Area Improvements without respect to depreciation. The Board shall adjust the policies to provide coverage and protection that is customarily carried by prudent owners of similar property in the area in which the Project is situated.

h. Deductible: The policy may contain a reasonable deductible and the amount of the deductible shall be added to the face amount of the policy in determining whether the insurance equals replacement cost.

i. The Association shall obtain and maintain the following insurance policies if and to the extent such insurance, with the coverages described below, is available at a reasonable premium cost:

(i) **Property Insurance.** A policy or policies all insurable Common Area improvements, including fixtures and building service equipment, against loss or damage by fire or other casualty, in an amount equal to at least ninety percent (90%) of the current full replacement cost (without respect to depreciation) of the Common Area, and exclusive of land, foundations, excavation and other items normally excluded from coverage. A replacement cost endorsement shall be part of the policy.

(ii) **Liability Insurance.** A combined single limit policy of public liability insurance in an amount not less than Two Million Dollars (\$2,000,000.00) covering the Common Area and all damage or injury caused by the negligence of the Association, the Board or any of its agents or the Members against any liability to the public or to any Member incident to the use of or resulting from any accident or intentional or unintentional act occurring in or about the Common Area. If available, each policy shall contain a cross liability endorsement in which the rights of the named insured shall not be prejudiced with respect to any action by one named insured against another named insured.

(iii) **Worker's Compensation.** Workers compensation insurance to the extent necessary to comply with all applicable laws of the State of California or the regulations of any governmental body or authority having jurisdiction over the Project.

(iv) **Fidelity Bond.** A fidelity bond naming the Board, the Members, the Association and such other persons as a majority of the Members may designate as obligees, in an amount equal to at least One Hundred Percent (100%) of the total sum budgeted for the Current Operation Account and Reserve Account for the current fiscal year. The fidelity bond shall contain a waiver of any defense based upon the exclusion of persons serving without compensation.

(v) **Directors and Officers' Liability Insurance.** To the extent it is available, the Association shall maintain a policy of insurance in the minimum amount of One Million Dollars (\$1,000,000) on any director, officer or member of a committee of the Association (collectively the "Agents") against any liability asserted against or incurred against the agent in such capacity or arising out of the Agent's status as such regardless of whether the Association would have the power to indemnify the Agent against such liability under applicable law; said insurance shall contain prior acts coverage.

(vi) **Additional Insurance and Bonds.** To the extent such insurance is reasonably obtainable, the Association may also purchase with common funds such additional insurance and bonds as it may, from time to time, determine to be necessary or desirable, including, without limiting the generality of this section, a fidelity bond, demolition insurance and flood insurance. The Board may purchase and maintain such insurance on personal property owned by the Association and any other insurance that it deems necessary or desirable.

j. **Coverage Not Available.** In the event any insurance policy, or any endorsement thereof, required by this Article is for any reason not available, then the Association shall obtain such other or substitute policy or endorsement as may be available which provides, as nearly as possible, the coverage described above. The Board shall notify the Owners of any material adverse changes in the Association's insurance coverage.

k. **Copies of Policies.** Copies of all insurance policies (or certificates thereof showing the premiums thereon have been paid) shall be retained by the Association and shall be available for inspection by Owners at any reasonable time.

l. **Adjustment of Losses.** The Board is appointed attorney-in-fact by each Owner to negotiate and agree on the value and extent of any loss under any policy carried pursuant to this Article. The Board is granted full right and authority to compromise and settle any claims or enforce any claim by legal action or otherwise and to execute releases in favor of any insured.

m. **Waiver of Subrogation.** All casualty and liability insurance carried by the Association, or the Owners, shall contain provisions whereby the insurer waives rights of subrogation as to the Association, directors, officers, Owners, occupants of Lots, tenants, their family, guests, agents and employees.

n. **Insurance on Lots and Residences.** An Owner may carry whatever personal liability, property damage liability, fire and casualty insurance with respect to his or her Unit and personal property as the Owner desires. The homeowner is responsible for insuring his/her Unit from the sheetrock in, including cabinets and countertops. The Association shall have no responsibility for the adequacy or extent of such insurance coverage.

Subject to any restrictions imposed by any Mortgagees and Civil Code Section 1365.9 or a comparable superseding statute, the Board shall have the power and right to deviate from the insurance requirements contained in this Subsection, in any manner that the Board, in its discretion, considers to be in the best interests of the Association. If the Board elects to materially reduce the coverage from the coverage required in this Subsection, the Board shall make all reasonable efforts to notify the Members of the reduction in coverage and the reasons therefor at least 30 days before the effective date of the reduction.

Each Owner, by acceptance of a deed to a Unit, irrevocably appoints the Association as the Owner's attorney-in-fact for purposes of negotiating, accepting, compromising, releasing,

settling, distributing, and taking other related actions in connection with any insurance policy maintained by the Association and any losses or claims related thereto and agrees to be bound by the actions so taken as if the Owner had personally taken the action.

The Board periodically (and not less than once every 2 years) shall review the Association's insurance policies and make such adjustments to the policies' terms and conditions as the Board considers to be in the best interests of the Association. The review shall include an appraisal by a qualified appraiser of the current replacement costs of all covered property under the Association's policy unless the Board is satisfied that the current dollar limit of the property policy, coupled with the amount of actual reserves on hand, is equal to or greater than the current replacement costs.

**Subsection 1.4 Discharge of Liens:**

The Association shall discharge by payment, if necessary, any lien against the Common Area, and assess the cost thereof to the Member or Members responsible for the existence of said lien. Prior to any Board decision to discharge a lien, the Owner shall be given written notice and an opportunity for a hearing before the Board in order to present any defenses which may exist.

**Subsection 1.5 Assessments:**

The Association shall fix, levy, collect and enforce Assessments as set forth in Article V hereof.

**Subsection 1.6 Payment of Expenses:**

The Association shall pay all expenses and obligations incurred by the Association in the conduct of its business including, without limitation, all licenses, taxes or governmental charges levied or imposed against the property of the Association.

**Subsection 1.7 Enforcement:**

The Association shall enforce this Declaration.

**Subsection 1.8 Budget and Annual Report:**

Regardless of the number of Members or the amount of assets of the Association, the Board shall cause to be maintained a full set of books and records and statements according to the provisions of the By- Laws, Article V, Section 2, Subsection 2.3 and Subsection 1.11 below.

**Subsection 1.9 Documents to be provided to Prospective Purchaser:**

Upon written request, the Association shall provide to each requesting owner a copy of the items set forth in Civil Code Section 1368 (a), within 10 days of the mailing or delivery of the request. The Association's fee for providing these documents shall not exceed the reasonable cost to prepare and copy the requested items. The Association shall not impose or collect any Assessment, penalty, or fee in connection with a transfer of title or any other interest except the Association's actual costs to change its records, and the preparation and cost of reproducing the documents.

**Subsection 1.10 Following Maintenance Guidelines:**

The Association shall follow and abide by the Maintenance Guidelines (if any) for all Common Areas.

**Subsection 1.11 Documents to be Provided to Requesting Owner:**

For the purposes of this section, the following definitions shall apply:

(I) "Association records" means all of the following:

(A) Any financial document required to be provided to a member in Section 1365 of the Civil Code.

(B) Any financial document or statement required to be provided in Section 1368 of the Civil Code.

(C) Interim unaudited financial statements, periodic or as compiled, containing and of the following:

(i) Balance sheet.

(ii) Income and expense statement.

(iii) Budget comparison;

(iv) General ledger. A "general ledger" is a report that shows all transactions that occurred in an Association account over a specified period of time.

The records described in this paragraph shall be prepared in accordance with generally accepted accounting principles.

(D) Executed contracts not otherwise privileged under law.

(E) Written board approval of vendor or contractor proposals or invoices.

(F) State and federal tax returns.

(G) Reserve account balances and records of payments made from reserve accounts.

(H) Agendas and minutes of meetings of the members, the board of directors and any committees appointed by the board of directors; excluding, however, agendas, minutes, and other information from executive sessions of the board of directors as described in Section 1363.05.

(I) (i) Membership lists, including name, property address and mailing address, if the conditions set forth in clause (ii) are met and except as otherwise provided in clause (iii).

(ii) The member requesting the list shall state the purpose for which the list is requested which purpose shall be reasonably related to the requestor's interest as a member. If the Association reasonably believes that the information in the list will be used for another purpose, it may deny the member access to the list. If the request is denied, in any subsequent action brought by the member under subdivision (f), the Association shall have the burden to prove that the member would have allowed use of the information for purposes unrelated to his or her interest as a member.

(iii) A member of the Association may opt out of the sharing of his or her name, property address, and mailing address by notifying the association in writing that he or she prefers to be contacted via the alternative process described in subdivision (c) of Section 8330 of the Corporations Code. This opt-out shall remain in effect until changed by the member.

(J) Check registers.

(a) "Enhanced Association records" means invoices, receipts and canceled checks for payments made by the Association, purchase orders approved by the Association, credit card statements for credit cards issued in the name of the Association, statements for services rendered, and reimbursement requests submitted to the Association, provided that the person submitting the reimbursement request shall be solely responsible for removing all personal identification information from the request.

(b) (1) The Association shall make available association records and enhanced Association records for the time periods and within the timeframes provided in subdivisions (i) and (j) for inspection and copying by a member of the Association, or the member's designated representative. The Association may bill the requesting member

for the direct and actual cost of copying requested documents. The Association shall inform the member of the amount of the copying costs before copying the requested documents.

(2) A member of the Association may designate another person to inspect and copy the specified Association records on the member's behalf. The member shall make this designation in writing.

(c) (1) The Association shall make the specified association records available for inspection and copying in the Association's business office within the common interest development.

(2) If the Association does not have a business office within the development, the association shall make the specified association records available for inspection and copying at a place that the requesting member and the Association agree upon.

(3) If the Association and the requesting member cannot agree upon a place for inspection and copying pursuant to paragraph (2), or if the requesting member submits a written request directly to the Association for copies of specifically identified records, the Association may satisfy the requirement to make the Association records available for inspection and copying by mailing copies of the specifically identified records to the member by first-class mail within the timeframes set for the in subdivision (j).

(4) The Association may bill the requesting member for the direct and actual cost of copying and mailing requested documents. The Association shall inform the member of the amount of the copying and mailing costs, and the member shall agree to pay those costs, before copying and sending the requested documents.

(5) In addition to the direct and actual costs of copying and mailing, the Association may bill the requesting member an amount not in excess of ten dollars (\$10) per hour, and not to exceed two hundred dollars (\$200) total per written request, for the time actually and reasonably involved in redacting the enhanced Association records as provided in paragraph (2) of subdivision (a). The Association shall inform the member of the estimated costs, and the member shall agree to pay those costs, before retrieving the requested documents.

(d) (1) Except as provided in paragraph (2), the Association may withhold or redact information from the Association records for any of the following reasons:

(A) The release of the information is reasonably likely to lead to identify theft. For the purposes of this section, "identity theft" means the unauthorized use of another person's personal identifying information to obtain credit, goods, services, money or property. Examples of information that may be withheld or redacted pursuant to this paragraph include bank account numbers of members or vendors, social security or tax identification numbers, and check, stock, and credit card numbers.

(B) The release of the information is reasonably likely to lead to fraud in connection with the Association.

(C) The information is privileged under law. Examples include documents subject to attorney-client privilege or relating to litigation in which the Association is or may become involved, and confidential settlement agreements.

(D) The release of the information is reasonably likely to compromise the privacy of an individual member of the Association.

(E) The information contains any of the following:

(i) Records of a-la-carte goods or services provided to individual members of the Association for which the Association received monetary consideration other than assessments.

(ii) Records of disciplinary actions, collection activities, or payment plans of homeowners other than the homeowner requesting the records.

(iii) Any person's personal identification information, including, without limitation, social security number, tax identification number, driver's license number, credit card account numbers, bank account number, and bank routing number.

(iv) Agendas, minutes, and other information from executive sessions of the board of directors as described in Section 1363.05, except for executed contracts not otherwise privileged. Privileged contracts shall not include contracts for maintenance, management, or legal services.

(v) Personnel records other than the payroll records required to be provided under paragraph (2).

(vi) Interior architectural plans, including security features, for individual homes.

(2) Except as provided by the attorney-client privilege, the Association may not withhold or redact information concerning the compensation paid to employees, vendors, or contractors. Compensation information for individual employees shall be set forth by job classification or title, not by the employee's name, social security number, or other personal information.

(3) No Association, officer, director, employee, agent or volunteer of the Association shall be liable for damages to a member of the Association as the result of identify theft or other breach of privacy because of the failure to withhold or redact that member's information under this subdivision unless the failure to withhold or redact the information was intentional, willful, or negligent.

(4) If requested by the requesting homeowner, an Association that denies or redacts records shall provide a written explanation specifying the legal basis for withholding or redacting the requested records.

(e) (1) The Association records, and any information from them, may not be sold, used for a commercial purpose, or used for any other purpose not reasonably related to a member's interest as a member. The Association may bring an action against any person who violates this section for injunctive relief and for actual damages to the Association caused by the violation.

(2) This section may not be construed to limit the right of the Association to damages for misuse of information obtained from the Association records pursuant to this section or to limit the right of an Association to injunctive relief to stop the misuse of this information.

(3) The Association shall be entitled to recover reasonable costs and expenses, including reasonable attorney's fees, in a successful action to enforce its rights under this section.

(f) A member of the Association may bring an action to enforce the member's right to inspect and copy the Association records. If a court finds that the Association unreasonably withheld access to the Association records, the court shall award the member reasonable costs and expenses, including reasonable attorney's fees, and may assess a civil penalty of up to five hundred dollars (\$500) for the denial of each separate written request. A cause of action under this section may be brought in small claims court if the amount of the demand does not exceed the jurisdiction of that court. A prevailing Association may recover any costs if the court finds the action to be frivolous, unreasonable, or without foundation.

(g) The provisions of this section apply to any community service organization or similar entity, as defined in paragraph (3) of subdivision (c) of Section 1368, that is related to the Association, and this section shall operate to give a member of the

community service organization or similar entity a right to inspect and copy the records of that organization or entity equivalent to that granted to Association members by this section.

(h) Requesting parties shall have the option of receiving specifically identified records by electronic transmission or machine-readable storage media as long as those records can be transmitted in a redacted format that does not allow the records to be altered. The cost of duplication shall be limited to the direct cost of producing the copy of a record in that electronic format.

(i) The time periods for which specified records shall be provided is as follows:

(1) Association records shall be made available for the current fiscal year and for each of the previous two fiscal years.

(2) Minutes of member and board meetings shall be permanently made available. If a committee has decision making authority, minutes of the meetings of that committee shall be made available one week after the meeting, and shall thereafter be permanently made available.

(j) The timeframes in which access to specified records shall be provided to a requesting member is as follows:

(1) Association records prepared during the current fiscal year, within 10 business days following the Association's receipt of the request.

(2) Association records prepared during the previous two fiscal years, within 30 calendar days following the Association's receipt of the request.

(3) Any record of statement available pursuant to Section 1365 or 1368, within the timeframe specified therein.

(4) Minutes of member and board meetings, within the timeframe specified in subdivision (d) of Section 1363.05.

(5) Minutes of meetings of committees with decision making authority for meetings commencing on or after January 1, 2007, within 15 calendar days following approval.

(6) Membership list, within the timeframe specified in Section 8330 of the Corporations Code.

(l) There shall be no liability pursuant to this section for an Association that fails to retain records for the periods specified in subdivision (i) that were created prior to January 1, 2006.

(m) As applied to the Association and its members, the provisions of this section are intended to supersede the provisions of Sections 8330 and 8333 of the Corporations Code to the extent those sections are inconsistent.

(n) The provisions of this section shall not apply to any common interest development in which separate interests are being offered for sale by a subdivider under the authority of a public report issued by the Department of Real Estate so long as the subdivider or all sub dividers offering those separate interests for sale, or any employees of those sub dividers or any other person who receives direct or indirect compensation from any of those sub dividers, comprise a majority of the members of the board of directors of the Association. Notwithstanding the foregoing this section shall apply to that common interest development no later than 10 years after the close of escrow for the first sale of a separate interest to a member of the general public pursuant to the public report issued for the first phase of the development.

The summary of the Association's reserves disclosed pursuant to paragraph (2) shall not be admissible in evidence to show improper financial management of the Association, provided

that other relevant and competent evidence of the financial condition of the Association is not made inadmissible by this provision.

Notwithstanding a contrary provision in the governing documents, a copy of the operating budget shall be annually distributed not less than 30 days nor more than 90 days prior to the beginning of the Association's fiscal year.

(b) A review of the financial statement of the Association shall be prepared in accordance with generally accepted accounting principles by a licensee of the California Board of Accountancy for any fiscal year in which the gross income to the Association exceeds seventy-five thousand dollars (\$75,000). A copy of the review of the financial statement shall be distributed within 120 days after the close of each fiscal year.

(c) In lieu of the distribution of the pro forma operating budget required by subdivision (a), the board of directors may elect to distribute a summary of the pro forma operating budget to all of its members with a written notice that the pro forma operating budget is available at the business office of the Association or at another suitable location within the boundaries of the development, and that copies will be provided upon request and at the expense of the Association. If any member requests that a copy of the pro forma operating budget required by subdivision (a) be mailed to the member, the Association shall provide a copy to the member by first-class United States mail at the expense of the Association and delivered within five days. The written notice that is distributed to each of the Association members shall be in at least 10-point boldface type on the front page of the summary of the budget.

(d) A statement describing the Association's policies and practices in enforcing lien rights or other legal remedies for default in payment of its assessments against its members shall be annually delivered to the members not less than 30 days nor more than 90 days immediately preceding the beginning of the Association's fiscal year.

(e) (1) A summary of the Association's property, general liability, earthquake, flood, and fidelity insurance policies, which shall be distributed not less than 30 days nor more than 90 days preceding the beginning of the Association's fiscal year, that includes all of the following information about each policy:

- (A) The name of the insurer.
- (B) The type of insurance.
- (C) The policy limits of the insurance.
- (D) The amount of deductibles, if any.

(2) The Association shall, as soon as reasonably practicable, notify its members by first-class mail if any of the policies described in paragraph (1) have lapsed, been canceled, and are not immediately renewed, restored, or replaced, or if there is a significant change, such as a reduction in coverage or limits or an increase in the deductible, as to any of those policies. If the Association receives any notice of nonrenewal of a policy described in paragraph (1), the Association shall immediately notify its members if replacement coverage will not be in effect by the date the existing coverage will lapse.

(3) To the extent that any of the information required to be disclosed pursuant to paragraph (1) is specified in the insurance policy declaration page, the Association may meet its obligation to disclose that information by making copies of that page and distributing it to all of its members.

(4) The summary distributed pursuant to paragraph (1) shall contain, in at least 10-point boldface type, the following statement: "This summary of the Association's policies of insurance provides only certain information, as required by subdivision (e) of Section 1365 of the Civil Code, and should not be considered a substitute for the complete policy terms and

conditions contained in the actual policies of insurance. Any Association member may, upon request and provision of reasonable notice, review the Association's insurance policies and, upon request and payment of reasonable duplication charges, obtain copies of those policies. Although the Association maintains the policies of insurance specified in this summary, the Association's policies of insurance may not cover your property, including personal property or, real property improvements to or around your dwelling, or personal injuries or other losses that occur within or around your dwelling. Even if a loss is covered, you may nevertheless be responsible for paying all or a portion of any deductible that applies. Association members should consult with their individual insurance broker or agent appropriate additional coverage." The above disclosures shall be summarized on the form in Civil Code Section 1365.2.5.

### **Subsection 1.12 Association's Obligations to Distribute Information To Prospective Buyers.**

#### **OBLIGATIONS OF SELLERS AND THE ASSOCIATION:**

(a) The Association shall, as soon as practicable before transfer of title to the separate interest or execution of a real property sales contract therefore, provide the following to the prospective purchaser:

(1) A copy of the governing documents of the common interest development, including any operating rules, and including a copy of the Association's articles of incorporation, or, if not incorporated, a statement in writing from an authorized representative of the Association that the Association is not incorporated.

(2) A copy of the most recent documents distributed pursuant to Section 1365.

(4) A true statement in writing obtained from an authorized representative of the Association as to the amount of the Association's current regular and special assessments and fees, any assessments levied upon the owner's interest in the common interest development that are unpaid on the date of the statement, and any monetary fines or penalties levied upon the owner's interest and unpaid on the date of the statement. The statement obtained from an authorized representative shall also include true information on late charges, interest, and costs of collection which, as of the date of the statement, are or may be made a lien upon the owner's interest in a common interest development pursuant to Section 1367 or 1367.1.

(5) A copy or a summary of any notice previously sent to the seller pursuant to subdivision (h) of Section 1363 that sets forth any alleged violation of the governing documents that remains unresolved at the time of the request. The notice shall not be deemed a waiver of the Association's right to enforce the governing documents against the owner or the prospective purchaser of the separate interest with respect to any violation. This paragraph shall not be construed to require an Association to inspect an owner's separate interest.

(6) A copy of the preliminary list of defects provided to each member of the Association pursuant to Section 1375, unless the Association and the builder subsequently enter into a settlement agreement or otherwise resolve the matter and the Association complies with Section 1375.1. Disclosure of the preliminary list of defects pursuant to this paragraph shall not waive any privilege attached to the document. The preliminary list of defects shall also include a statement that a final determination as to whether the list of defects is accurate and complete has not been made.

(7) A copy of the latest information provided for in Section 1375.1.

(8) Any change in the Association's current regular and special assessments and fees which have been approved by the Association's board of directors, but have not become due and payable as of the date disclosure is provided pursuant to this subdivision.

(b) Upon written request, an Association shall, within 10 days of the mailing or delivery of the request, provide the owner of a separate interest with a copy of the requested items specified in paragraphs (1) to (8), inclusive, of subdivision (a). The Association may charge a fee for this service, which shall not exceed the Association's reasonable cost to prepare and reproduce the requested items.

## **Section 2. Powers:**

In addition to the powers stated in its Articles and By-Laws, or elsewhere provided for herein, and without limiting the generality thereof, the Association shall have the following powers:

### **Subsection 2.1 Easements:**

The Association shall have authority to grant easements where necessary for utilities and sewer facilities over the Common Area to serve the Common Area(s) and the Units.

### **Subsection 2.2 Access:**

The Board and its agents or employees shall have the exclusive right to enter a Unit as necessary in connection with construction, maintenance or emergency repair for the benefit of the Common Area or the Owners in common. Except in case of emergency, forty-eight (48) hours notice shall be given to the Owner or the occupant of such Unit.

### **Subsection 2.3 Manager:**

The Association may employ a professional manager (a "Manager") or other persons and hire independent contractors or an employee to perform all or any part of the duties and responsibilities of the Association, except for the responsibility to levy fines, impose discipline, hold hearings, file suit, record or foreclose liens, or make capital expenditures, provided that any contract with a firm or person appointed as a manager or managing agent, or any contract providing for services by the Declarant, sponsor or builder, shall not exceed a one (1) year term.

### **Subsection 2.4 Association Rules:**

The Board may, from time to time, and subject to the provisions of this Declaration, the By-Laws, and the Articles of Incorporation, adopt rules for the management of the Project in accordance with the provisions set forth in the By-Laws, Article V, Section 1, Subsection 1.1.

A copy of the Rules so adopted shall be furnished to each Owner, and each Owner, his family, guests, employees, invitees, licensees and tenants shall comply with such Rules.

### **Subsection 2.5 Rule Changes:**

(a) The board of directors shall provide written notice of a proposed rule change to the members at least 30 days before making the rule change. The notice shall include the text of the proposed rule change and a description of the purpose and effect of the proposed rule change. Notice is not required under this subdivision if the board of directors determines that an immediate rule change is necessary to address an imminent threat to public health or safety or imminent risk of substantial economic loss to the Association.

(b) A decision on a proposed rule change shall be made at a meeting of the board of directors, after consideration of any comments made by Association members.

(c) As soon as possible after making a rule change, but not more than 15 days after making the rule change, the board of directors shall deliver notice of the rule change to every Association member.

If the rule change was an emergency rule change made under subdivision (d), the notice shall include the text of the rule change, a description of the purpose and effect of the rule change, and the date that the rule change expires.

(d) If the board of directors determines that an immediate rule change is required to address an imminent threat to public health or safety, or an imminent risk of substantial economic loss to the Association, it may make an emergency rule change; and no notice is required, as specified in subdivision (a). An emergency rule change is effective for 120 days, unless the rule change provides for a shorter effective period. A rule change made under this subdivision may not be readopted under this subdivision.

(e) Members of an Association owning 5 percent or more of the separate interests may call a special meeting of the members to reverse a rule change.

(f) A special meeting of the members may be called by delivering a written request to the president or secretary of the board of directors, after which the board shall deliver notice of the meeting to the Association's members and hold the meeting in conformity with Section 7511 of the Corporations Code. The written request may not be delivered more than 30 days after the members of the Association are notified of the rule change. Members are deemed to have been notified of a rule change on delivery of notice of the rule change, or on enforcement of the resulting rule, whichever is sooner. For the purposes of Section 8330 of the Corporations Code, collection of signatures to call a special meeting under this section is a purpose reasonably related to the interests of the members of the Association. A member request to copy or inspect the membership list solely for that purpose may not be denied on the grounds that the purpose is not reasonably related to the member's interests as a member.

(g) The rule change may be reversed by the affirmative vote of a majority of the votes represented and voting at a duly held meeting at which a quorum is present (which affirmative votes also constitute a majority of the required quorum), or if the declaration or bylaws require a greater proportion, by the affirmative vote or written ballot of the proportion required. In lieu of calling the meeting described in this section, the board may distribute a written ballot to every member of the Association in conformity with the requirements of Section 7513 of the Corporations Code.

(h) Unless otherwise provided in the declaration or bylaws, for the purposes of this section, a member may cast one vote per separate interest owned.

(i) A meeting called under this section is governed by Chapter 5 (commencing with Section 7510) of Part 3 of Division 2 of Title 1 of, and Sections 7612 and 7613 of, the Corporations Code.

(j) A rule change reversed under this section may not be readopted for one year after the date of the meeting reversing the rule change. Nothing in this section precludes the board of directors from adopting a different rule on the same subject as the rule change that has been reversed.

(k) As soon as possible after the close of voting, but not more than 15 days after the close of voting, the board of directors shall provide notice of the results of a member vote held pursuant to this section to every Association member. Delivery of notice under this subdivision is subject to Section 1350.7.

(l) This section does not apply to an emergency rule change made under subdivision (d) of Section 1357.130.

### **Subsection 2.6 Enforcement of Rules and Restrictions:**

The Board shall have the power, obligation and duty to enforce the provisions of this Declaration, the By-Laws, and the Rules. In the event of a breach of any of the restrictions contained in this Declaration, the Bylaws, or of any Rules by an Owner, his family, guests, employees, invitees, licensees or tenants, the Board may enforce the obligations of each Owner and licensee to obey such Rules or restrictions in any manner provided by law or in equity, including but not limited to, appropriate legal action, and/or suspension of the Owner's voting right and right to use the common facilities of the Project; however, such suspension may not be for a period in excess of thirty (30) days, and may not be imposed without notice and hearing as herein provided, for an infraction of such Rules and restrictions.

In addition to the other remedies herein set forth, the Board, by majority vote, may levy a fine in accordance with the schedule of monetary penalties adopted by the Board against such Owner, after appropriate notice and hearing as herein provided, in an amount (for each such violation) which bears a reasonable relationship to the gravity of the infraction and the burden on the Association. The right to levy fines, hold disciplinary hearings or otherwise impose discipline on Members under this section is vested solely in the Board and may not be delegated to any Director, officer, or Manager or other employees of the Board or Declarant.

Prior to making any decision that a breach has occurred or to impose any penalty provided herein for breach of any Rules enacted hereunder or restrictions contained in this Declaration, the Board shall send written notice to the Owner specifying the nature of the alleged infraction and provide an opportunity to the Owner for a hearing before the Board regarding such infraction and the penalty to be imposed.

Notwithstanding anything to the contrary in this Declaration, neither the Board nor the Association or Members shall have the power to cause a forfeiture or abridgment of an Owner's right to the full use and enjoyment of his individually owned Unit, including access thereto over and across the Common Area, because of such Owner's failure to comply with the provisions of this Declaration or of the By-Laws or any Rules adopted by the Association relating to the operation of the Common Area or Common Area facilities except when such loss or abridgment results from a judgment or arbitration award or on account of a foreclosure or under the power of sale granted herein for failure of the Owner to pay the Assessments levied pursuant to the provisions of this Declaration. In the event the Board institutes legal action pursuant to this section, any judgment rendered in any such action shall include costs of collection, court costs and reasonable attorneys' fees. A monetary penalty or reimbursement charge imposed by the Association as a disciplinary measure for failure of a Member to comply with the governing instruments or as a means of reimbursing the Association for costs incurred by the Association in the repair of damage to Common Areas and facilities for which the Member was allegedly responsible or in bringing the Member and his Unit into compliance with the governing instruments may not be characterized nor treated in the Governing Documents as an Assessment which may become a lien against the Member's Unit enforceable by a sale of the Unit in accordance with Section 2924 of the California Civil Code.

The provisions of the above paragraph do not apply to charges imposed against an Owner consisting of reasonable late payment penalties for delinquent Assessments and/or charges to reimburse the Association for the loss of interest and for costs reasonably incurred (including attorneys' fees) in its efforts to collect delinquent Assessments.

### **Subsection 2.7 Acquisition of Property:**

The Association shall have the power to acquire (by gift, purchase or otherwise), own, hold, improve, build upon, operate, maintain, convey, sell, lease, transfer, dedicate for public use or otherwise dispose of real or personal property in connection with the affairs of the Association. This shall include, but not be limited to, the right of the Association to purchase a Unit, to borrow funds for such purchase and to make an Assessment for the purchase of a Unit. However, except with the vote or written assent of a majority of the voting power of the Association residing in Members other than the Declarant, the Board is prohibited from (1) incurring aggregate expenditures for capital improvements to the Common Area in any fiscal year in excess of five percent (5%) of the budgeted gross expenses of the Association for that fiscal year and (2) selling during any fiscal year property of the Association having an aggregate fair market value greater than five percent (5%) of the budgeted gross expenses of the Association for that fiscal year.

### **Subsection 2.8 Loans:**

The Association shall have the power to borrow money and, with the assent (by vote or written consent) of 51% of each class of Members, to mortgage, pledge, deed in trust, or hypothecate any or all of its real or personal property as security for money borrowed or debts incurred.

### **Subsection 2.9 Dedication:**

The Association shall have the power to dedicate, sell or transfer all or any part of the Common Area to any public agency, authority, or utility for such purposes and subject to such conditions upon which the Members may agree. No such dedication or transfer shall be effective unless an instrument has been signed by 51% of each class of Members, or three-fourths (3/4) of the total voting membership other than the Declarant after conversion to a single class of Members, agreeing to such dedication, sale or transfer.

### **Subsection 2.10 Contracts:**

The Association shall have the power to contract for goods and/or services for the Common Area(s), for the common facilities or interests of the Owners or for the Association, subject to limitations set forth elsewhere in this Declaration or the By-Laws of the Association.

### **Subsection 2.11 Delegation:**

The Association shall have the power to delegate certain portions of its authority and powers to committees, officers or employees of the Association. However, the Association may not delegate the authority to levy fines, hold hearings, impose discipline, make capital expenditures, file suit on behalf of the Association, record a claim of lien or institute foreclosure proceedings for failure to pay Assessments, to an officer, employee or committee.

### **Subsection 2.12 Litigation/Alternative Dispute Resolution:**

The Association shall have the power to institute, defend, settle or intervene in litigation, mediation, arbitration or administrative proceedings on behalf of the Association pursuant to Code of Civil Procedure Section 383, or a comparable superseding statute. If, and to the extent that, there is any inconsistency between this subsection 2.11, and the applicable provisions of the Code of Civil Procedure and the Civil Code pertaining to the commencement of an action by the Association to recover damages for construction defects, the applicable provisions of the California statutes shall control.

### **Subsection 2.13 Power of Attorney:**

Each Owner, for himself, his successors and assigns, shall be deemed upon purchasing his Condominium to have appointed the officers of the Association, or any of them, as his true and lawful attorney, in his name, place and stead, to prosecute, settle and/or release any claims arising out of the Owners' acquisition and/or joint ownership of the Common Areas of the Project. Such power shall be utilized only upon express authorization of the Board given by resolution adopted by the Board at a meeting for which all Members are given advance written notice specifying the nature of the proposed action for which the power of attorney is to be utilized.

### **Subsection 2.14 Notice of Action Against the Declarant or Developer:**

Not later than 30 days prior to the filing of any civil action by the association against the declarant or other developer of a common interest development for alleged damage to the common areas, alleged damage to the separate interests that the association is obligated to maintain or repair, or alleged damage to the separate interests that arises out of, or is integrally related to, damage to the common areas or separate interests that the association is obligated to maintain or repair, the board of directors of the association shall provide a written notice to each member of the association who appears on the records of the association when the notice is provided. This notice shall specify all of the following:

(1) That a meeting will take place to discuss problems that may lead to the filing of a civil action.

(2) The options, including civil actions that are available to address the problems.

(3) The time and place of this meeting.

(b) Notwithstanding subdivision (a), if the association has reason to believe that the applicable statute of limitations will expire before the association files the civil action, the association may give the notice, as described above, within 30 days after the filing of the action.

## **ARTICLE V - ASSESSMENTS**

### **Section 1. Covenants for Maintenance Assessments:**

Declarant hereby covenants and agrees for each Condominium owned by it within the Project, and each Owner of any Condominium, by acceptance of a deed is deemed to covenant and agree, to pay to the Association the Assessments levied pursuant to this Article. Declarant and each Owner thereby vest in the Association the right to bring all actions for the collection of such charges and to enforce the lien created hereby. Such right remains with the Association and such obligations run with the land so that each successive Owner or Owners of record of a Condominium in the Project will become liable to pay all Assessments which become a lien during the time he or she is the record Owner of any Condominium in the Project.

Each Assessment levied by the Association under this Article constitutes a separate Assessment. Each Assessment, together with interest thereon, costs of collection and reasonable attorneys' fees will be a charge on the Condominium and be a continuing lien upon the Condominium against which each such Assessment is made. The Association, as the agent of all Owners, has a separate lien, and a separate lien with power of sale is hereby created, upon each Condominium against which an Assessment is made to secure the payment of any Assessments

under this Article. Each such lien for any particular month's charge will also secure interest thereon, if the same is not paid when due, and costs of suit and reasonable attorneys' fees to be fixed by the court if action or suit is brought to collect such charge. The priority of all such liens shall be in inverse order so that upon foreclosure of the lien for a particular month's charge, any foreclosure sale pursuant thereto will be made subject to all liens securing the respective monthly charge on such Condominium for succeeding months.

Each Assessment, together with interest, attorneys' fees and costs of collection, shall also be a separate, distinct and personal obligation of the Owner of the Condominium at the time when the Assessment fell due. The personal obligation for delinquent Assessments will not pass to an Owner's successor in title unless expressly assumed by such successor, but the lien for such delinquent Assessment shall remain and, if unpaid by such successive Owner, may be foreclosed as provided in this Declaration. After a record Owner transfers record title to his Condominium, he will not be liable for any charge thereafter assessed against such Condominium. A contract seller of any Condominium will continue to be liable for all such charges until a conveyance by him of the Condominium subject to the Assessment is recorded in the Office of the City and County Recorder.

## **Section 2. Regular Monthly Assessments:**

A. The Board shall establish regular monthly Assessments for operation and maintenance by the procedures established in this Section. The Assessments shall be due and payable in monthly installments on the first day of each month commencing on the first day of the first month following close of escrow of the sale of the first Condominium.

Each Residential Unit and each Residential Owner will share the expense of the Common Area pro-rated on the basis of Percentage Interest In Common Area except as stated in the Budget.

Not less than sixty (60) days prior to the beginning of each fiscal year, the Board shall estimate the total charges to be paid from the maintenance fund during such year (including a reasonable reserve for contingencies) and distribute a copy of a pro forma operating statement (budget) to each Member. All funds budgeted, allocated, assessed and collected for deferred maintenance and capital improvements shall be designated and used solely for those specific purposes.

The Association shall maintain a reserve account equal to at least 10% of the yearly budget.

The Board may not impose a regular Assessment that is more than twenty percent (20%) greater than the regular Assessment for the Association's preceding fiscal year or impose special Assessments which in the aggregate exceed five percent (5%) of the budgeted gross expenses of the Association for that fiscal year without the approval of Members, constituting a quorum, casting a majority of votes at a meeting or election of the Association conducted according to the voting requirements of Article III, Section 4 of this Declaration. For purposes of this section, quorum means more than fifty percent (50%) of the Members.

The above paragraph does not limit Assessment increases necessary for emergency situations, which are defined as extraordinary expenses:

(1) required by order of a court; or

(2) necessary to repair or maintain the Project or its Common Area(s) where a threat to personal safety within the Project is discovered; or

(3) necessary to repair or maintain the Project or its Common Area(s) that the Board could not have reasonably foreseen in preparing and distributing its pro forma operating budget pursuant to the By-Laws of the Association. However, prior to the imposition or collection of an Assessment under this subsection (3), the Board shall pass a resolution containing written findings as to the necessity of the extraordinary expenses involved and why the expenses were not or could not have been foreseen in the budgeting process, and the resolution shall be distributed to the Members with the notice of Assessment.

Within one hundred and twenty (120) days after the end of each fiscal year, the Members shall receive an accounting of Assessment receipts and disbursements for that fiscal year.

B. The Board of Directors of the Association must, prior to any increase in Assessments, follow one of the following two procedures:

(1) Prepare and distribute to all Members a copy of the operating budget not less than 45 days nor more than 60 days prior to the beginning of the Association's fiscal year, which operating budget shall include:

a) The estimated revenue and expenses on an accrual basis.

b) A summary of the Association's reserves based upon the most recent review or study conducted pursuant to Section 1365.5 of the Civil Code, which shall be printed in bold type and include all of the following:

i) The current estimated replacement cost, estimated remaining life, and estimated useful life of each major component.

ii) As of the end of the fiscal year for which the study is prepared:

(A) The current estimate of the amount of cash reserves necessary to repair, replace, restore, or maintain major components.

(B) The current amount of accumulated cash reserves actually set aside to repair, replace, restore or maintain major components.

C) The percentage that the amount determined for purposes of clause (ii) of subparagraph (B) is of the amount determined for purposes of clause (i) of subparagraph (B).

c) A statement as to whether the Board has determined or anticipates that the levy of one or more special Assessments will be required to repair, replace, or restore any major component or to provide adequate reserves therefor.

d) A general statement addressing the procedures used for the calculation and establishment of those reserves to defray the future repair, replacement, or additions to those major components that the Association is obligated to maintain;

or

e) Obtain the approval of Members constituting a quorum (more than 50 percent of the Members of the Association), casting a majority of the votes at a meeting or election of the Association conducted in accordance with Chapter 5 (commencing with Section 7510) of Part 3 of Division 2 of Title 1 of the Corporations Code and Section 7613 of the Corporations Code.

The Association shall provide notice by first-class mail to the Members of any increase in regular Assessments of the Association, not less than 30, nor more than 60 days prior to the increased Assessment becoming due.

Association dues or charges shall include an adequate reserve fund for maintenance, repairs and replacement of those Common Area improvements that must be replaced on a periodic basis, and dues or charges to be put into the reserve fund shall be payable in regular monthly Assessments rather than by special Assessments.

### **Section 3. Special Assessments:**

In addition to the regular Assessments authorized herein, the Board may levy, in any fiscal year, a special Assessment applicable to that year for capital improvements, correction of inadequacy of the maintenance fund, defraying, in whole or in part, the cost of any construction, reconstruction, unexpected repair or replacement of improvements in the Common Area(s) and such other matters as the Board may deem appropriate; provided, however, that in any fiscal year the Board may not impose special Assessments which in the aggregate exceed five percent (5%) of the budgeted gross expenses for that fiscal year without the approval of Members, constituting a quorum, casting a majority of votes at a meeting or election of the Association conducted according to the voting requirements of Article III, Section 4 of this Declaration. For purposes of this section, quorum means more than fifty percent (50%) of the Members. This section does not limit Assessment increases necessary for "emergency situations" as defined in Section 2 of this Article.

Any such special Assessment shall be levied upon the same basis as that prescribed herein for the levying of regular Assessments except that:

A special Assessment against Owners to raise funds for the rebuilding or major repair of the structural Common Area containing Units of the Project shall be levied upon the basis of the ratio of the square footage of the floor area of the Unit to be assessed to the total square footage of the floor area of all Units to be assessed; and

The provisions hereof regarding special Assessments do not apply in the case where a reimbursement charge against a Member is a remedy utilized by the Board of Directors to reimburse the Association for costs incurred in bringing the Member and his Unit into compliance with the provisions of this Declaration, the By-Laws, Articles of Incorporation or the Rules.

The Association shall provide notice by first-class mail to the Owners of any increase in special Assessments of the Association, not less than 30 nor more than 60 days prior to the increased Assessment becoming due.

**Section 4. Reimbursement Charges:**

The Board shall levy a reimbursement charge against any Unit Owner and the Condominium owned by such Owner whose failure to comply with this Declaration, the By-Laws, Articles of Incorporation or the Rules has necessitated an expenditure of moneys by the Association from the maintenance fund to bring such Owner and Condominium into compliance with said instruments or in otherwise performing its functions under this Declaration. Such reimbursement charge shall be for the purpose of reimbursing the Association, and shall be due and payable to the Association when levied.

**Section 5. Non-Waiver of Assessments:**

The omission by the Board, before the expiration of any year, to fix the Assessments for that or the next year shall not be deemed a waiver or modification in any respect of the provisions of this Declaration or a release of any Owner from the obligations to pay the Assessments, or any installment thereof, for that or any subsequent year. In the instance of such omission, the Assessment fixed for the preceding year shall continue until a new Assessment is fixed. No Owner may waive or otherwise escape liability for the Assessments provided for herein by non-use of the Common Area, abandonment of the Condominium or any attempt to renounce rights in the Common Area.

**Section 6. Enforcement:**

Each Unit Owner, upon becoming such Owner, shall be deemed to covenant and agree to pay to the Association every Assessment provided for in this Declaration and shall be deemed to agree to the enforcement of all such Assessments in the manner specified herein.

Fines and penalties for violation of the Governing Documents are not "Assessments" and are not enforceable by Assessment lien pursuant to Subsection 6.3 below, but are enforceable by court proceedings.

Regular and special Assessments shall be delinquent 15 days after they become due. In the event an attorney is employed for collection of any Assessment or to enforce compliance with the terms and conditions of this Declaration, each Owner agrees to pay all reasonable costs incurred in collecting delinquent Assessments including but not limited to (i) legal expenses incurred; (ii) recording costs; (iii) costs incurred with the title companies or foreclosure service providers; and (iv) costs associated with court actions, in addition to any other amounts due or any other relief or remedy to which the Association is entitled (collectively "reasonable costs of collection").

(1) Late charges. Any Assessment not paid when due will be deemed to be delinquent and shall be charged with a late payment equal to ten (10) percent of the delinquent amount.

(2) Interest. Any Assessment not paid within thirty (30) days after the date on which it becomes due shall thereafter earn interest from the date of delinquency at the rate of twelve percent (12%) per annum, or at the maximum rate allowed by law.

(3) Application of Payments. Payments received on delinquent Assessments shall be applied to the Owner's account in the following order of priority: first, to the principal owed; then to accrued interest and late charges; then to legal expenses; then to title company and foreclosure service company charges and other reasonable costs of collection. Payments on account of principal shall be applied in reverse order so that the oldest arrearages are retired first. Interest shall continue to accrue on unpaid balances of principal, and other costs and charges imposed according to Civil Code Section 1366(d) or a comparable superseding section.

In addition to any other remedies herein or by law provided, the Association, or its authorized representative, may enforce the obligations of the Owners to pay the Assessments provided for in this Declaration, and each of them, in any manner provided by law or in equity, according to the following procedures.

#### **Subsection 6.1 Demand Letter:**

When an Owner becomes delinquent in the payment of Assessments and before recording a lien pursuant to Subsection 6.3 below, the Association or its authorized representative shall mail, by certified mail return receipt requested, a "Demand" letter ("Demand Letter") to an Owner advising the Owner that he or she is late in the payment of Assessments and requesting immediate payment. The letter shall also provide an itemized statement of the total amount of Assessments then due and the amount of any late charges, any attorney's fees, collection costs, and interest then posted to the Owner's account (and a statement of how each of those sums was calculated). In addition, the letter shall advise the Owner of the Association's fee and penalty procedures and the Association's collection policies, including the right of the Association to the reasonable costs of collection.

#### **Subsection 6.1.1**

6.1.1. An owner may dispute the debt noticed by submitting to the board a written explanation of the reasons for his or her dispute. The board shall respond in writing to the owner within 15 days of the date of the postmark of the explanation, if the explanation is mailed within 15 days of the postmark of the notice. (2) An owner, other than an owner of any interest that is described in Section 11212 of the Business and Professions Code that is not otherwise exempt from this section pursuant to subdivision (a) of Section 11211.7, may submit a written request to meet with the board to discuss a payment plan for the debt noticed pursuant to subdivision (a). The association shall provide the owners the standards for payment plans, if any exist. The board shall meet with the owner in executive session within 45 days of the postmark of the request, if the request is mailed within 15 days of the date of the postmark of the notice, unless there is no regularly scheduled board meeting within that period, in which case the board may designate a committee of one or more members to meet with the owner.

The amount of the assessment, plus any costs of collection, late charges, and interest assessed in accordance with Section 1366, shall be a lien on the owner's interest in the common interest development from and after the time the association causes to be recorded with the county recorder of the county in which the separate interest is located, a notice of delinquent assessment, which shall state the amount of the assessment and other sums imposed in accordance with Section 1366, a legal description of the owner's interest in the common interest development against which the assessment and other sums are levied, the name of the record owner of the owner's interest in the common interest development against which the lien is imposed. In order for the lien to be enforced by nonjudicial foreclosure, the notice of delinquent assessment shall state the name and address of the trustee authorized by the association to

enforce the lien by sale. The notice of delinquent assessment shall be signed by the person designated in the declaration or by the association for that purpose, or if no one is designated, by the president of the association, and mailed in the manner set forth in Section 2924b, to all record owners of the owner's interest in the common interest development no later than 10 calendar days after recordation. Within 21 days of the payment of the sums specified in the notice of delinquent assessment, the association shall record or cause to be recorded in the office of the county recorder in which the notice of delinquent assessment is recorded a lien release or notice of rescission and provide the owner of the separate interest a copy of the lien release or notice that the delinquent assessment has been satisfied. A monetary charge imposed by the association as a means of reimbursing the association for costs incurred by the association in the repair of damage to common areas and facilities for which the member or the member's guests or tenants were responsible may become a lien against the member's separate interest enforceable by the sale of the interest under Sections 2924, 2924b, and 2924c, provided the authority to impose a lien is set forth in the governing documents. It is the intent of the Legislature not to contravene Section 2792.26 of Title 10 of the California Code of Regulations, as that section appeared on January 1, 1996, for associations of subdivisions that are being sold under authority of a subdivision public report, pursuant to Part 2 (commencing with Section 11000) of Division 4 of the Business and Professions Code.

Except as indicated in subdivision (d), a monetary penalty imposed by the association as a disciplinary measure for failure of a member to comply with the governing instruments, except for the late payments, may not be characterized nor treated in the governing instruments as an assessment that may become a lien against the member's subdivision separate interest enforceable by the sale of the interest under Sections 2924, 2924b, and 2924c.

A lien created pursuant to this subsection shall be prior to all other liens recorded subsequent to the notice of assessment, except that the declaration may provide for the subordination thereof to any other liens and encumbrances.

An association may not voluntarily assign or pledge the association's right to collect payments or assessments, or to enforce or foreclose a lien to a third party, except when the assignment or pledge is made to a financial institution or lender chartered or licensed under federal or state law, when acting within the scope of that charter or license, as security for a loan obtained by the association; however, the foregoing provision may not restrict the right or ability of an association to assign any unpaid obligations of a former member to a third party for purposes of collection. Subject to the limitations of this subdivision, after the expiration of 30 days following the recording of a lien, the lien may be enforced in any manner permitted by law, including sale by the court, sale by the trustee designated in the notice of delinquent assessment, or sale by a trustee substituted pursuant to Section 2934a. Any sale by the trustee shall be conducted in accordance with Sections 2924, 2924b, and 2924c applicable to the exercise of powers of sale in mortgages and deeds of trust. The fees of a trustee may not exceed the amounts prescribed in Sections 2924c and 2924d.

Nothing in this section or in subdivision (a) of Section 726 of the Code of Civil Procedure prohibits actions against the owner of a separate interest to recover sums for which a lien is created pursuant to this section or prohibits an association from taking a deed in lieu of foreclosure.

If it is determined that a lien previously recorded against the separate interest was recorded in error, the party who recorded the lien shall, within 21 calendar days, record or cause to be recorded in the office of the county recorder in which the notice of delinquent assessment is recorded a lien release or notice of rescission and provide the owner of the separate interest with a declaration that the lien filing or recording was in error and a copy of the lien release or notice of rescission.

An association that fails to comply with the procedures set forth in this section shall, prior to recording a lien, recommence the required notice process. Any costs associated with recommencing the notice process shall be borne by the association and not by the owner of a separate interest.

**Subsection 6.2 Claims Within the Jurisdiction of Small Claims Court.  
(Currently \$7, 500 or less):**

This subsection shall apply only to claims by the Association for payment of delinquent Assessments in the amount of \$7, 500 or less.

If the Demand Letter does not result in payment in full and the Owner's Assessment account remains delinquent for more than 30 days, and interest charges begin to accrue, the Association shall be entitled to pursue the Association's claims against the Owner in a Small Claims court action. If the Association takes this action, Subsection 6.3 does not apply to that collection matter.

**Subsection 6.3 Enforcement by Lien:**

(a) Recordation of a Notice of Delinquent Assessment. At any time after the Demand Letter is sent to an Owner by certified mail and the Association elects not to pursue its claims for delinquent Assessments in Small Claims Court, the Association shall be entitled to cause to be recorded against the title to the delinquent Owner's Unit in the Office of the San Francisco County Recorder a Notice of Delinquent Assessment. At least 30 days prior to recording a lien upon the Owner's Unit, the Association shall notify the Owner of record by certified mail, the notice stated in Government Code Section 1367.1(a)(1). As more particularly provided in California Civil Code Section 1367 or a comparable superseding statute, the amount of any delinquent or regular or special or special individual Assessment, together with any late charges, interest and costs (including reasonable attorneys' fees) attributable thereto or incurred in the collection thereof, shall become a lien upon the Unit of the Owner so assessed only when the Association causes to be recorded in the Office of the County Recorder of the County, a Notice of Delinquent Assessment executed by an authorized representative of the Association, setting forth (a) the amount of the delinquent Assessment(s) and other sums duly imposed pursuant to this Article VI and California Civil Code Section 1366, (B) the legal description of the Owner's Unit against which the Assessment and other sums are levied, (C) the name of the Owner of record of such Unit, (D) the name and address of the Association, and (E) the name and address of the trustee authorized by the Association to enforce the lien by sale.

(b) Notification of All Record Owners of the Liened Unit. Once a Notice of Delinquent Assessment has been recorded, the Association must send a copy of the Notice to all record Owners of the Unit within ten (10) days following the date of recordation. That mailing shall be certified, with all postage prepaid.

(c) Options Available to Liened Owners. The Owner of the Unit to which the Notice of Delinquent Assessment pertains shall have thirty (30) days from the recordation date of the Notice of Delinquent Assessment to pursue either of the following alternatives:

(i) Payment in Full and Termination of Collection Process. The Owner can pay all amounts shown in the Notice of Delinquent Assessment and thereby conclude the collection process. Upon payment in full of the sums specified in the Notice of Delinquent Assessment, the Association shall cause to be recorded a further notice stating the satisfaction and release of the lien thereof.

(ii) Alternative of Payment Under Protest; Limitations on Exercise of This Option. Alternatively, an Owner who receives a Notice of Delinquent Assessment can: (A) pay in full and under protest all delinquent sums, interest, late charges, and other noted costs of collection; and (B) send the Association, by certified mail, a written notice that the amount is paid under protest. On receipt of that notice, the Association shall inform the protesting Owner of his or her right to have the matter resolved through alternative dispute resolution according to Civil Code Section 1354 or any superseding statute, through the filing of a civil action or through use of any other dispute resolution procedures available through the Association pursuant to Article XI, Section 7 of this Declaration. The Association shall hold monies received under protest in a segregated account until such time as the alternative dispute resolution process has concluded, provided the Owner's protest is timely and properly made and the limitations described in the immediately following paragraph do not apply. If an Owner elects to pursue alternative dispute resolution according to Civil Code Section 1354 or a superseding statute, it shall be the responsibility of the Owner to comply with the statutory requirements relating to the preparation and service of a Request for Resolution. The right of an Owner to pay delinquent Assessments under protest and to demand alternative dispute resolution pursuant to the above paragraph may be exercised only two times in any single calendar year and not more than three times in any five calendar years. Except to the extent that notices are required by law, the Association shall not provide advice to Owners regarding technical requirements of these alternative dispute procedures. Owners are advised to consult their own counsel regarding such matters.

(d) Continuation With Foreclosure Proceedings. Following the later of 30 days from recordation of the Notice of Default or the conclusion of alternative dispute resolution procedures following an Owner's protest in a manner that does not result in a binding adverse determination against the Association, the Association's lien may be enforced in any manner permitted by law or this Declaration, including sale by the court, sale by the trustee designated in the Notice of Delinquent Assessment, or sale by a trustee substituted under Civil Code section 2934a.

Foreclosure by the Association of its lien may be by judicial foreclosure or by nonjudicial foreclosure by the trustee designated in the Notice of Delinquent Assessment or by a trustee substituted pursuant to California Civil Code Section 2934a. Any sale of a Unit by a trustee acting pursuant to this Section shall be conducted according to California Civil Code Sections 2924, 2924b and 2924c, applicable to the exercise of powers of sale in mortgages or deeds of trust.

Each Owner does hereby waive, to the extent of any liens created pursuant to the Declaration, whether such liens are now in existence or are created at any time in the future, the benefit of any homestead or exemption laws of the State of California now in effect, or in effect in the future.

#### **Subsection 6.4 Enforcement by Suit for Claims Above \$7, 500**

If the sum of the delinquent Assessments is in excess of \$7,500, the Association may commence and maintain a suit at law for such delinquent Assessments against any Owner or Owners personally obligated to pay Assessments and such suit will be maintained in the name of the Association. Any judgment rendered in any such action shall include the amount of the delinquency, together with interest thereon, costs of collection, court costs and reasonable attorneys' fees in such amount as the court may adjudge against the delinquent Owner. Suit to recover judgment for unpaid Assessments shall be maintainable without foreclosing or waiving the lien provided for in the preceding Subsection 6.3. The Association may not recover twice in connection with a single delinquent Assessment.

#### **Section 7. Power of Foreclosure and Sale:**

Each Owner does hereby appoint the Association, as trustee, to enforce any lien created pursuant to this Declaration and to foreclose such lien by private power of sale as provided in Division III, Part 4, Title XIV, Chapter 2, Article I of the Civil Code of the State of California and Civil Code Section 1367, as such statutes may be revised, amended or altered from time to time, or by judicial foreclosure, and does further grant the Association, as such trustee, the power to sell the Unit of any such defaulting Owner, or any part thereof, for lawful money of the United States, to the highest bidder to satisfy such lien.

The lien provided for herein shall be in favor of the Association, shall be for the benefit of all Owners and shall secure payment of all sums set forth in the Notice of Delinquent Assessment together with all sums becoming due and payable in accordance with this Declaration after the date of recordation of said Notice of Delinquent Assessment. The Association shall have the power to bid at any foreclosure sale and to purchase, acquire, hold, lease, mortgage and convey any Unit. In the event such foreclosure is by action in court, reasonable attorneys' fees, court costs, title search fees, interest and all other costs and expenses shall be allowed to the extent permitted by law.

#### **Section 8. Transfer of Unit by Sale or Foreclosure:**

The following rules shall govern the Association's rights to enforce its Assessment collection remedies following the sale or foreclosure of a unit.

(a) Except as provided in paragraph (b), below, the sale or transfer of any Unit shall not affect any Assessment lien duly recorded with respect to that Unit before the sale or transfer, and the Association can continue to foreclose its lien in spite of the change in ownership.

(b) The Association's Assessment lien shall be extinguished as to all delinquent sums, late charges, interest, and costs of collection incurred before the sale or transfer of a Unit under a foreclosure or exercise of a power of sale by the holder of a prior encumbrance (but not under a deed-in-lieu of foreclosure). A "prior encumbrance" means any first mortgage or other mortgage or lien recorded before the Association's Assessment lien.

(c) No sale or transfer of a Unit as the result of foreclosure, exercise of a power of sale, or otherwise, shall relieve the new Owner of that Unit (whether it be the former beneficiary of the first mortgage or other prior encumbrance, or a third party acquiring an interest in the Unit) from liability for any Assessments thereafter becoming due or from the lien thereof.

(d) Any Assessments, late charges, interest, and associated costs of collection that are lost as a result of a sale or transfer covered by paragraph (b), above, shall be deemed to be a

common expense collectible from the Owners of all of the Units, including the person who acquires the Unit and his or her successors and assigns.

(e) No sale or transfer of a Unit as the result of foreclosure, exercise of a power of sale, or otherwise, shall affect the Association's right to maintain an action against the foreclosed previous Owner of the Unit personally to collect the delinquent Assessments, late charges, interest, and associated costs of collection incurred by that prior Owner prior to the sale or transfer.

#### **Section 9. Release of Lien:**

Upon payment of the delinquent Assessment or the satisfaction thereof, the Association shall record, in the same manner as the Notice of Assessment, a further certificate stating the satisfaction and release of the lien.

#### **Section 10. Status of Assessment Lien:**

Upon request by any Owner, the Association will furnish, for the benefit of any prospective purchaser or present or prospective encumbrancer of such Condominium, a statement showing all amounts then due which are secured by such lien. A reasonable fee, not to exceed Fifty Dollars (\$50.00), may be charged for the preparation of such statement.

#### **Section 11. Subordination of Lien to Encumbrance:**

Notwithstanding any provision to the contrary in this Declaration, the lien for Assessments created by this Declaration shall be subject and subordinate to and shall not affect the rights of the holder of any recorded first Mortgage or first deed of trust upon such Condominium made in good faith and for value. In the event any lien imposed under the provisions hereof is destroyed by reason of the foreclosure of any Mortgage or deed of trust on the Condominium subject to such lien, there shall be a lien on the interest of the purchaser at such foreclosure sale to secure all Assessments, whether regular or special, charged to such Condominium after the date of such foreclosure sale, which lien shall have the same effect and be enforced in the same manner as provided herein.

For purposes of this Section, a Mortgage or deed of trust may be given in good faith or for value even though the Mortgagee or the Beneficiary of such Mortgage or deed of trust has constructive or actual knowledge of the Assessment lien provisions of this Declaration.

No amendment of this Section shall affect the rights of the holder of any mortgage or deed of trust recorded prior to recordation of such amendment unless the Mortgagee or Beneficiary joins in the execution of such amendment.

#### **Section 12. Association Funds:**

The Assessments collected by the Association shall be held in trust by the Association for and on behalf of each Owner and shall be used solely for the operation, care and maintenance of the Project as provided in this Declaration. The Board shall allocate a portion of said funds as collected for the annual maintenance and operation of the Project as specified in the annual budget and the Board shall allocate a portion of said funds as collected as reserves for contingencies, replacement and deferred maintenance of the capital improvements of the Project as specified in the annual budget. Said funds shall be deposited, as allocated, into the appropriate bank accounts and said accounts shall be separately maintained by the Association. Upon sale or

transfer of any Unit by any Owner, the Owner's interest in the trust funds shall be deemed automatically transferred to the successor or transferee of such Owner.

In the event that the Board retains a Manager, the Board may delegate the authority to deposit or withdraw funds to responsible representatives of the Manager so retained. The Manager may additionally be authorized to establish a common trustee account for deposit of Assessments as collected. Any funds deposited in such a common trustee account shall be allocated as previously specified herein.

**Section 13. Books of Account:**

The Board shall maintain full, complete and correct books of account of the operation of the Project and vouchers supporting expenditures. Any Owner, or the duly authorized representative thereof, may at any time and at his own expense cause an audit or inspection to be made of the books and records of the Association.

**ARTICLE VI - EASEMENTS**

**Section 1. Generally:**

There are hereby specifically reserved for the benefit of the Units and Owners, in common and for each Unit and Owner severally, and for the Association, as their respective interests apply, the easements, reciprocal negative easements, secondary easements and rights of way as particularly identified in this Article.

**Section 2. Easements for Utilities and Maintenance:**

The rights and duties of the Owners regarding sanitary sewer, water, electricity, gas and telephone lines and facilities, television and cable television, and heating facilities shall be as follows:

Whenever sanitary sewer, water, electricity, gas, television reception, cable television, telephone lines or connections, heating or air-conditioning conduits, ducts, or flues are installed within or upon Condominiums owned by other than each Owner served by said connections, the Owners served by said connections shall have the right, and are hereby granted an easement to the full extent necessary therefor, to enter upon the Condominiums to install, repair, replace and generally maintain said connections as and when necessary.

Whenever sanitary sewer, water, electricity, gas, television reception, cable television, or telephone lines or connections, heating or air-conditioning conduits, ducts, or flues are installed within the Property which connections serve more than one Condominium, the Owner served by said connection shall be entitled to the full use and enjoyment of such portions of said connections as service his Condominium.

In the event of a dispute between Owners regarding the repair or rebuilding of said connections, or regarding the sharing of the cost thereof, then upon written request of one of such Owners addressed to the Association, the matter shall be submitted to the Board of Directors who shall decide the dispute, and the decision of the Board shall be final and conclusive on the parties.

Easements over and under the Property for the installation, repair, and maintenance of electric, telephone, water, gas, and sanitary sewer lines and facilities, heating and air-conditioning facilities, cable or master television antenna lines, drainage facilities, walkways, and landscaping as shown on the Plan, are hereby reserved by Declarant and its successors and assigns, including the Association.

### **Section 3. Ingress and Egress:**

There is hereby reserved to each Unit, as dominant tenement, a non-exclusive easement appurtenant to each Unit over and across the Common Area, as servient tenement, for ingress, egress, use and enjoyment of said Common Area subject to the limitations provided in this Declaration.

### **Section 4. Deck Areas:**

Certain Units and Owners shall have an exclusive easement, and such exclusive easement is hereby granted for the use, possession, and enjoyment of any deck whose number corresponds to the adjacent unit number, which is deeded to such Unit. This exclusive easement shall be subject, however, to the right of the Association to enter in and upon such areas for the purposes of maintaining and repairing the same and/or the building, if appropriate pursuant to this Declaration, and enforcing the terms hereof.

Notwithstanding anything stated herein above, each Owner who is granted an exclusive easement to use a portion of the Restricted (Exclusive Use) Common Area described as a private deck assigned to a Unit shall cultivate, maintain, irrigate, fertilize, and otherwise care for all landscaping and improvements located within the deck at said Owner's sole expense. No Owner shall build or place or cause to be built or placed any shed, pet area, or other structure within his or her deck nor shall any Owner add any landscaping to the deck without the prior written consent of the Architectural Control Committee and the Board.

### **Section 5. Encroachment Easements:**

Each Condominium is hereby declared to have an easement over all adjoining Condominiums and the Common Area for the purpose of accommodating any encroachment due to engineering errors, errors in original construction, settlement or shifting of the building, or any other cause. There shall be valid easements for the maintenance of said encroachments as long as they shall exist, and the rights and obligations of Owners shall not be altered in any way by said encroachment, settlement or shifting; provided, however, that in no event shall a valid easement for encroachment be created in favor of an Owner or Owners if said encroachment occurred due to the willful misconduct of said Owner or Owners. In the event that a structure is partially or totally destroyed, and then repaired or rebuilt, the Owners of each Condominium agree that minor encroachments over adjoining Condominiums or Common Area shall be permitted and that there shall be valid easements for the maintenance of said encroachments so long as they shall exist.

## **ARTICLE VII - USE RESTRICTIONS**

In addition to all of the covenants contained herein, the use of the Project and each Condominium therein is subject to the following:

### **Section 1.1. Residential Condominium Use:**

No Unit shall be occupied and used except for residential purposes by the Owners and their family members, tenants, and social guests, and no trade or business (other than a home office use) shall be conducted therein, except that Declarant, its successors or assigns, may use any Unit owned by Declarant for a model home site and display and sales office until the last Unit is sold by Declarant. No tent, shack, trailer, basement, garage, outbuilding or structure of a temporary character shall be used at any time as a residence, either temporarily or permanently.

Those portions of the Property designed and designated for parking shall be restricted for that use exclusively.

No Unit or any portion thereof in the Project shall be leased, subleased, occupied, rented, let, or sublet. There shall be no "time-shares." The term "time sharing" as used herein shall be deemed to include, but shall not be limited to, any agreement, plan, program, or arrangement under which the right to use, occupy or possess the Unit or Units, or any portion thereof in the Project, rotates among various persons, either corporate, partnership, individual, or otherwise, on a periodically recurring basis for value exchanged, whether monetary or like kind use privileges, according to a fixed or floating interval or period of time of twenty-five (25) consecutive calendar days or less; provided, however, that this section shall not be construed to limit the personal use of any Unit or any portion thereof in the Project by any Owner or his or her or its social or familial guests.

Any amendment of this Section shall require the vote or written consent of 51% of Owners of Units and the San Francisco Redevelopment Agency or its successor.

### **Section 2. [Intentionally Deleted]**

### **Section 3. Nuisances:**

No noxious, illegal, or offensive activities shall be carried on in any Unit, or on any part of the Project, nor shall anything be done thereon which may be or may become an annoyance or a nuisance to or which may in any way interfere with the quiet enjoyment of each Owner of his respective Unit, or which shall in any way increase the rate of insurance for the Project, or cause any insurance policy to be canceled or to cause a refusal to renew a policy, or which will impair the structural integrity of the Project.

### **Section 4. Vehicle Restrictions:**

No trailer, camper, mobile home, commercial vehicle, truck (other than standard size pickup truck), inoperable automobile, boat or similar equipment shall be permitted to remain upon any area within the Project. Commercial vehicles shall not include sedans or standard size pickup trucks which are used both for business and personal use, provided that any signs or markings of a commercial nature on such vehicles are unobtrusive and inoffensive as determined by the Board. No noisy or smoky vehicles shall be operated on the Project. No off-road unlicensed motor vehicles shall be operated upon the Project.

The Association and its authorized agents shall have the right to enforce all parking and vehicle restrictions set forth in this section, and to remove or cause the removal of vehicles, trailers, or other equipment parked in violation of this section in accordance with the provisions

of Vehicle Code §22658, or other applicable laws, codes, and statutes. To the extent required by law, the Association shall be authorized to post within the Common Areas all signage required by law to authorize the towing of vehicles parked in violation of these restrictions.

The Board shall have the authority to promulgate further reasonable rules and regulations of uniform application regarding the parking of vehicles within the Project in order to implement effectively the purposes and intent of this section.

In the event that an Owner or resident believes that he or she should be granted a variance from any of the parking or vehicle restrictions contained in this section, the Owner/resident may apply to the Board for a variance. Except as provided in the paragraph below, no variance may be granted by the Board until the following procedures have been satisfied: The Board shall conduct a hearing on the request for a variance. Notice of the hearing (which shall generally describe the desired variance) shall be presented in the notice of the meeting of the Board of Directors at which the matter will be considered and acted on and a copy of that notice shall be delivered to all other Owners. The Board meeting at which the matter will be considered shall not take place sooner than 15 days following issuance of the notice. Variances shall be granted only if the Board, in its sole discretion, determines that the activity permitted by the variance will not materially or adversely compromise the purposes and intent of these restrictions.

If a variance is needed for the short-term parking of vehicles in a manner or at a location not authorized by this Section, the Board or the Manager, if authorized by the Board, may grant a short-term variance without complying with the notice and hearing procedures described above. A short-term variance shall be defined as the parking of any vehicle or equipment in a manner or at a location not otherwise authorized by this section for periods not to exceed 72 hours, and which does not create a safety hazard or, in the opinion of the Board or the Manager, materially detract from the aesthetics of the development.

#### **Section 4.1. Parking**

There are fewer spaces than units. Parking will be rented to Owners of Units with the largest square footages, starting with the larger units and then each smaller unit, through a License Agreement for the Use of Parking Spaces. The owners of these units (and/or adult members of their household) shall be given a license to use parking spaces pursuant to a License Agreement for the Use of Parking Spaces. Parking spaces are restricted to the parking of one (1) automobile or motorized cycle per parking space. No parking area shall be used for storage or trash of any kind. Bicycles shall be stored only in storage spaces designated as bicycle storage areas. The Owner of each Unit shall be eligible to have opportunities from time to time to rent a parking space in the garage, subject to the terms of that certain irrevocable License Agreement between the Association and the owner of each Unit. Each Owner shall be bound by the terms and conditions of said Agreement. The Association shall rent to any Owner a space to park on a month to month basis, subject to a monthly fee payable to the Association. The determination of which of the first Owners will be entitled to use a parking space shall be set forth in the License Agreement.

#### **Section 4.2. Handicapped Parking:**

The parking space(s) identified as spaces "P-HC" on the Plan is/are handicapped spaces. If the occupants of the Units assigned these spaces are not appropriately licensed to use a

handicapped parking space by the State of California and the occupant of another Unit assigned a parking space is appropriately licensed (the "Licensed Occupant"), and the space assigned this Unit is not a handicapped parking space, the Association, on receipt of a written request from the Licensed Occupant, shall require the Owner of a Unit assigned a handicapped space to exchange the handicapped space with the space assigned to the Unit occupied by the Licensed Occupant. The exchange shall remain in effect as long as the Licensed Occupant occupies the Unit and remains licensed to use a handicapped space and shall terminate automatically on the date the Licensed Occupant ceases to occupy the Unit or ceases to be appropriately licensed to use a handicapped parking space, whichever occurs first. The exchange shall be temporary and shall not alter the permanent parking space(s) assigned to any Unit and appurtenant to that Unit. The Owners of the Unit assigned the handicapped spaces covenant to cooperate with the Association and any Licensed Occupant in effecting any exchange required under this Section.

If two or more handicapped spaces are assigned to a Unit where the occupants are not licensed to use a handicapped space and the spaces have not been exchanged with the space of the Licensed Occupant, the selection of the available handicapped space to be exchanged with the space of the Licensed Occupant shall be by agreement between the Owners of the Units with the assigned handicapped spaces. If the Owners cannot reach agreement for any reason within ten days after receipt of written request from the Licensed Occupant to effect the exchange, the selection shall be made by lottery by the President of the Association. The selection resulting from the lottery shall be final and binding. The right to exchange a non-handicapped space for a handicapped space shall be available to any Licensed Occupant on a first-come, first-serve basis. The Board may adopt Rules regulating the exchange of non-handicapped spaces for handicapped spaces that are not inconsistent with the provisions of this Section.

#### **Section 5. Signs:**

Except as provided in this Section and Article XI, Section 5 below regarding the Declarant's rights, owners of Residential Units are not prohibited from displaying or posting noncommercial signs, posters, flags, or banners in a Residential Unit, except as required for the protection of public health or safety or if the posting or display would violate a local, state or federal law. A noncommercial sign, poster, flag, or banner may be made of paper, cardboard, cloth, plastic, or fabric and may be posted or displayed from the yard, window, door, balcony, or outside wall of the Residential Unit, but may not be made of lights, roofing, siding, paving materials, flora, or balloons, or any other similar building, landscaping, or decorative component, or include the painting of architectural surfaces. Noncommercial signs and posters that are more than 9 square feet in size and noncommercial flags or banners that are more than 15 square feet in size may not be displayed or posted.

#### **Section 6. Animals:**

No animals or birds of any kind, shall be raised, bred, or kept in any Condominium, or on any portion of the Project, except that no more than one dog, and two birds or cats may be kept so long as they are not kept for any commercial purpose, and provided they are kept under reasonable control at all times. No pet may be kept on the Project which results in a nuisance as prohibited in Section 2 of this Article, or which weighs 75 pounds or more. Pets shall be allowed in the Restricted (Exclusive Use) Common Area without a leash as long as under verbal control of an occupant of a Unit. In all other Common Areas, pets must be on a leash which is held by a person capable of controlling the pet. Declarant or Association may cause any unleashed dog

found within the Common Area to be removed to a pound or animal shelter under the jurisdiction of the City of San Francisco, State of California. No dog whose barking disturbs other Owners shall be permitted to remain on the Project. Owners shall prevent their pets from soiling any portion of the Common Area.

Prior to any decision by the Board pursuant to this section that an Owner is responsible for the maintenance of a nuisance or any decision to remove a pet from the Project, the Owner shall be provided with written notice specifying the nature of the infraction and an opportunity for a hearing before the Board. The remedies for an alleged nuisance shall not include any measures which may be characterized as "private self-help action" and any Board action in connection with this section shall comply with the provisions of Article IV, Section 2.5 of this Declaration.

#### **Section 7. Garbage and Refuse Disposal:**

All rubbish, trash and garbage shall be regularly removed from the Project, and shall not be allowed to accumulate thereon. Trash, garbage and other waste shall not be kept except in sanitary containers.

#### **Section 8. Radio and Television Antennas and Satellite Dishes:**

No alteration to or modification of the central television antenna system or satellite system or any subsequent cable or other system for television reception as maintained by the Association shall be permitted. An Owner shall be permitted to construct and/or operate his own external video or television antenna or satellite dish (of a diagonal or diameter measurement of 36 inches or less) without the written consent of the Board if such installation complies with any reasonable restrictions imposed by the Association through such Section 1376. Civil Code Section 1376 prohibits the Association from preventing the attachment of an antenna to the building if such antenna is not visible from any street or Common Area. Placement of antennas on the roof is subject to Rules and Regulations promulgated by the Board.

#### **Section 9. No Right to Lease:**

No Owner of a Residential Unit may lease, as leasing is restricted by the Redevelopment Agency limitations for this Project.

#### **Section 10. Clothes Lines:**

No exterior clotheslines shall be erected or maintained and there shall be no outside laundering or drying of clothes.

#### **Section 11. Power Equipment and Car Maintenance:**

No major power equipment, or car maintenance (other than emergency work) shall be permitted on the Project except with prior written approval of the Board. In deciding whether to grant approval the Board shall consider the effects of noise, air pollution, dirt or grease, fire hazard, interference with radio or television reception, and similar objections.

#### **Section 12. Liability of Owners for Damage to Common Area:**

An Owner shall be liable to the Association for all damages to the Common Area or improvements thereon caused by such Owner or any occupant of his Unit or guest, except for that portion of said damage, if any, fully covered by insurance. Liability of an Owner shall be established only after notice to the Owner and a hearing before the Board.

Owners shall not run wires down outside of the building nor drill holes and run wires going into the building.

**Section 13. Curtains or Drapes:**

All drapes or curtains visible from the street or Common Area shall be white or off-white, except with the written consent of the Architectural Control Committee. Only curtains, shades or blinds shall be used as window coverings. No paper, cardboard, aluminum foil, bedsheets or other things may be used as window coverings.

**Section 14. Wall Penetrations:**

There shall be no wall penetration of any type (including picture hangers) of more than one-half inch into the drywall. Any penetration into any wall beyond one-half inch may damage utilities located within the wall.

**Section 15. Moving In/Out and Contractor Rules:**

The Board may adopt Rules regulating the moving of property in and out of a Unit and regulating delivery of materials, supplies, packages, construction work hours, and means of ingress and egress to and from the Condominium. The Rules may include, but are not limited to, Rules regarding the times during which moving in or out may occur, coordination of two or more moves occurring within the same time period, protection for the elevator cabs, disposal of moving boxes and the posting of collateral to pay for damage to the Common Area.

**Section 16. Cook Tops:**

The use of cook top ranges within the Unit may increase condensation within the Unit. Excessive condensation can lead to problems with mold and mildew. Owners are advised to open windows and turn on hood exhaust fans when cook top ranges are in operation.

**Section 17. Deck Restrictions:**

No personal property, including furniture, artwork, planters or plants, space heaters, statuary, or other structures or vegetation in excess of five feet in height or which may be seen from any public street, right-of-way, or from any adjoining terrace, shall be placed on any terrace. Standing water on the terrace can lead to leaks into the Units below. Accordingly, Owners shall not allow water to pool or stand on terrace areas and shall make certain that all planters drain via lines into existing drain systems and/or all potted plants sit on evaporation dishes. No deck area may be used for storage or trash of any kind and must be kept free of any animal waste. No charcoal grills shall be allowed on decks or elsewhere.

**Section 18. Air Ventilation:**

Because the development does not contain a central heating, ventilation or air-conditioning system, in order to ensure periodic air changes within the Units and to avoid condensation build-up and its attendant problems of mold and mildew, Owners and occupants are advised to open the windows to their Units at least once a day to promote air changes within the Unit.

**Section 19. Low-Flow Toilets:**

The Units contain 1.6 gallon low-flow toilets as mandated by law. The low-flow toilets plug easily and if plugged and left unattended can overflow and significantly damage the Owner's Unit and Units below. Each Owner or occupant of a Unit shall maintain a "plumber's helper" or plunger nearby. In the event of an overflow, the toilet water shutoff valve should be closed immediately and a plumber contacted immediately. Each Owner shall be responsible for acquainting himself or herself with shutting off the water at the toilet in case of an overflow. Each Owner shall maintain their toilet and all the parts. The flapper must be replaced periodically and is the Owner's responsibility.

**Section 20. Noise Restrictions:**

Excessive noise shall be prohibited at all times. The proximity of living, working and commercial areas dictates that common sense, good judgment and consideration should be used by Owners and their guests at all times so as to avoid conflict over noise.

**Section 21. Smoking Restrictions:**

Smoking shall not be permitted in the Common Area, including outdoor Common Areas hallways or elevators at any time.

**Section 22. Exterior Penetrations:**

There shall be no penetration of any type of the exterior walls of the Project without the prior written consent of the Board. Any penetration into any such exterior wall could compromise the waterproofing of the Project. The Board is advised to seek the advice of a qualified water proofing expert prior to consenting to any proposed penetration.

**ARTICLE VIII - ARCHITECTURAL CONTROL**

**Section 1. Committee Purpose and Size:**

There shall be no modification, reconstruction or exterior change to any portion of the Common Area, including any Restricted (Exclusive Use) Common Areas, without the express written approval of the Architectural Control Committee which shall consist of three (3) persons. The Board of Directors may choose to act as the Architectural Control Committee.

**Section 2. Appointment, Removal and Term of Office:**

Declarant shall appoint all of the original members of the Architectural Control Committee and all of the replacements until the first anniversary of the issuance of the original Final Public Report for the Project. Declarant shall have the right to appoint and remove a majority of the members of the Architectural Control Committee until such time as the Owners other than Declarant own 90% or more of the Units or five (5) years after the issuance of the original Final Public Report for the Project, whichever occurs first.

After one year from the date of issuance of the original Final Public Report for the Project, the Board shall have the right to appoint one member to the Architectural Control Committee. When Declarant waives or no longer has the right to appoint and remove the members of the Architectural Control Committee, said right shall be vested solely in the Board.

All members appointed by the Board shall be Owners. Exercise of the right of appointment and removal, as set forth herein, shall be evidenced by the specification in the Minutes of the Association of each new Committee member appointed and each Member replaced or removed from the Architectural Control Committee. Vacancies on the Architectural Control Committee, however caused, shall be filled by the Declarant or the Board, whichever then has the power to appoint members.

### **Section 3. Duties:**

It shall be the duty of the Architectural Control Committee to consider and act upon such proposals or plans submitted to it pursuant to the terms of Section 5 hereof, to adopt architectural rules, to perform other duties delegated to it by the Association and to carry out all other duties imposed upon it by this Declaration.

### **Section 4. Meetings:**

The Architectural Control Committee shall meet from time to time as necessary to properly perform its duties hereunder. The vote or written consent of any majority of the Committee shall constitute an act by the Committee unless the unanimous decision of its members is otherwise required by this Declaration. The Committee shall keep and maintain a record of all actions taken by it at such meeting or otherwise. The Architectural Control Committee and its members shall be entitled to reimbursement for reasonable out-of-pocket expenses incurred in the performance of any Architectural Control Committee function.

### **Section 5. Application for Approval of Improvements:**

Any Unit Owner, except Declarant and its designated agents, proposing to perform any work of any kind whatever which requires the prior approval of the Architectural Control Committee shall apply to such Committee for approval by notifying the Architectural Control Committee of the nature of the proposed work in writing and furnishing such information as the Committee may require.

### **Section 6. Basis for Approval:**

- (1) The Association shall provide a fair, reasonable, and expeditious procedure for making its decision. The procedure shall be included in the Association's governing documents. The procedure shall provide for prompt deadlines. The procedure shall state the maximum time for response to an application or a request for reconsideration by the board of directors.
- (2) A decision on a proposed change shall be made in good faith and may not be unreasonable, arbitrary, or capricious.
- (3) A decision on a proposed change shall be consistent with any governing provision of law, including, but not limited to, the Fair Employment and Housing Act (Part 2.8 (commencing with Section 12900) of Division 3 of Title 2 of the Government Code).
- (4) A decision on a proposed change shall be in writing. If a proposed change is disapproved, the written decision shall include both an explanation of why the proposed change is disapproved and a description of the procedure for reconsideration of the decision by the board of directors.
- (5) If a proposed change is disapproved, the applicant is entitled to reconsideration by the board of directors of the Association at an open meeting of the board. This paragraph does not require reconsideration of a decision that is made by the board of directors at a meeting that satisfies the requirements of Section 1363.05. Reconsideration does not constitute "dispute resolution" under Civil Code Section 1363.820.

(b) Nothing in this section authorizes a physical change to the common area in a manner that is inconsistent with an Association's governing documents or governing law.

(c) An Association shall annually provide its members with notice of any requirements for Association approval of physical changes to property. The notice shall describe the types of changes that require Association approval and shall include a copy of the procedure used to review and approve or disapprove a proposed change.

Though it is recognized that the Committee's determination to approve or disapprove an improvement will, of necessity, be subjective to some degree, the members of the Committee shall act reasonably and in good faith. Factors commonly considered by the Committee in reviewing proposed improvements include the quality of workmanship and materials proposed for the improvement project; the harmony of the proposed improvement's exterior design, finish materials, and color with that of the existing structures; and the proposed location of the improvement in relation to existing topography, finished grade elevations, roads, Common Areas, and other structure.

#### **Section 7. Approval:**

All approvals shall be in writing; provided, however, that any request for approval which has not been rejected within thirty (30) days from the date of submission thereof to the Architectural Control Committee shall be deemed approved.

#### **Section 8. Liability:**

Neither the Architectural Control Committee nor any member thereof shall be liable to the Association or to any Owner for any damage, loss or prejudice suffered or claimed on account of: (a) the approval or disapproval of any plans, drawings and specifications, whether or not defective, (b) the construction or performance of any work, whether or not pursuant to approved plans, drawings and specifications, (c) the development of any property within the Project, or (d) the execution and filing of an estoppel certificate, whether or not the facts therein are correct; provided, however, that such member has acted in good faith on the basis of such information as may be possessed by him.

### **ARTICLE IX - MORTGAGEE RIGHTS AND PROTECTION**

Notwithstanding any other provisions of this Declaration to the contrary:

#### **Section 1. Mortgage Permitted:**

Any Owner may encumber his Unit with a Mortgage. For purposes of this Declaration a "Mortgage" means a deed of trust; and a "Mortgagee" also means the Beneficiary under a deed of trust. A "first Mortgage" similarly also means "a first deed of trust".

#### **Section 2. Subordination:**

Any lien created or claimed under the provisions of this Declaration is expressly made subject and subordinate to the rights of any first Mortgage that encumbers all or a portion of the Project, or any Unit, made in good faith and for value, and no such lien shall in any way defeat, invalidate, or impair the obligation or priority of such first Mortgage unless the Mortgagee expressly subordinates his interest, in writing, to such lien.

### **Section 3. Amendment:**

No amendment to this Declaration, the Articles or the By-Laws shall affect the rights of any Mortgagee under any Mortgage made in good faith and for value and recorded before the recordation of any such amendment unless the Mortgagee either joins in the execution of the amendment or approves it in writing as a part of such amendment. A Mortgagee who receives a request for approval of a proposed amendment and fails to respond negatively within thirty (30) days of receipt shall be deemed to have approved the amendment to the same extent as if the Mortgagee affirmatively approved such amendment in writing.

### **Section 4. Rights of Mortgagees:**

No breach of any of the Covenants, Conditions and Restrictions herein contained nor the enforcement of any lien provisions herein, shall render invalid the lien of any first Mortgage (meaning a Mortgage with first priority over any other Mortgage) on any Unit made in good faith and for value, but all of said Covenants, Conditions and Restrictions shall be binding upon and effective against any Owner whose title is derived through foreclosure or trustee's sale or otherwise. Notwithstanding any provision in the Declaration to the contrary, Mortgagees shall have the following rights:

All Institutional Lenders that have filed with the Association a request for notice of default shall be entitled to receive written notice from the Association of any default by the trustor of any deed of trust on a Unit (the beneficial interest in which is held by said Institutional Lender) in the performance of such trustor's obligations under the Governing Documents, which is not cured within thirty (30) days.

The Association shall discharge its obligation to notify Mortgagees by sending written notices required herein to the lender or lenders requesting notice, at the address given on the current request for notice.

First Mortgagees of individual Units may, jointly or singly, pay taxes or other charges which are in default and which may have become a charge against any Association common property and may pay overdue premiums on hazard insurance policies, or secure new hazard insurance coverage on the lapse of a policy, for such common property and first Mortgagees making such payments shall be owed immediate reimbursement for such payment from the Association. Entitlement to such reimbursement shall be reflected in an agreement in favor of all first Mortgagees of Units duly executed by the Association.

Any Mortgagee will, upon request, be entitled to (a) inspect the books and records of the Association during normal business hours, and (b) receive an annual audited financial statement of the Association within ninety (90) days following the end of the fiscal year of the Association, and (c) written notice of all Association meetings and be permitted to designate a representative to attend all such meetings.

Association dues or charges shall include an adequate reserve fund for maintenance, repairs and replacement of those Common Area improvements that must be replaced on a periodic basis, and shall be payable in regular monthly assessments rather than by special Assessments.

Each holder of a first Mortgage lien on a Unit who comes into possession of the Unit by virtue of foreclosure of the Mortgage, or any purchaser at a foreclosure sale under a first deed of trust, will take the Unit free of any claims for unpaid Assessments and charges against the Unit which accrue prior to the time such holder comes into possession of the Unit except for claims from a pro rata reallocation of such Assessments or charges to all Units including the mortgaged Unit, and except for Assessment liens recorded prior to the Mortgage.

Any agreement for professional management of the Project, or any other contract providing for services of the developer, sponsor or builder, may not exceed one (1) year. Any such agreement must provide for termination by either party for cause on ninety (90) days' written notice, and thirty (30) days written notice with cause, and without payment of a termination fee on ninety (90) days or less written notice.

The Project governing instruments contain no provisions creating a "right of first refusal," but should any such rights be created in the future, any such rights shall not impair the rights of any Mortgagee to: (1) foreclose or take title to a Unit pursuant to the remedies provided in the Mortgage, or (2) accept a deed (or assignment) in lieu of foreclosure in the event of a default by a mortgagor, or (3) interfere with a subsequent sale or lease of a Unit so acquired by the Mortgagee.

All insurance policies held by the owners' association must contain a standard mortgage clause providing that the insurer will notify the mortgagee or guarantor on any unit in the condominium project at least 10 days prior to any lapse, cancellation, or material modification of any insurance policy maintained by the owners' association.

#### **Section 5. Consent to Action:**

Except as provided by statute or by other provision of the Governing Documents in case of substantial destruction or condemnation of the Project, and further excepting any reallocation of interests in the Common Area(s) which might occur pursuant to any plan of expansion or phased development contained in the original Governing Documents:

A. The consent of Owners of Units to which at least sixty-seven percent (67%) of the votes in the Association are allocated and the approval of Eligible Mortgage Holders (as defined in Article I of this Declaration) holding Mortgages on Units which have at least sixty-seven percent (67%) of the votes of Units subject to eligible holder Mortgages, shall be required to terminate the legal status of the Project as a condominium project.

B. The vote required to terminate that legal status of the Project after substantial destruction or condemnation of the Project shall be sixty-seven percent (67%) of the total voting power of the Association and fifty-one percent (51%) of the votes allocated to Units which are subject to first Mortgages held by Eligible Mortgage Holders (as defined in Article I of this Declaration).

C. The consent of Owners of Units to which at least sixty-seven percent (67%) of the votes in the Association are allocated and the approval of Eligible Mortgage Holders holding Mortgages on Units which have at least fifty-one percent (51%) of the votes of the Units subject to first Mortgages held by Eligible Mortgage Holders shall be required to add or amend any material provisions of the Governing Documents which establish, provide for, govern or regulate any of the following: (i) voting; (ii) Assessments, Assessment liens or subordination of such

liens; (iii) reserves for maintenance, repair and replacement of the Common Area(s) (or Units if applicable); (iv) responsibility for maintenance and repair of the several portions of the Project; (v) except as provided in Article VIII, Section 5, expansion or contraction of the Project or the addition, annexation or withdrawal of property to or from the Project; (vi) except as provided in Article VIII, Section 5, boundaries of any Unit; (vii) except as provided in Article VIII, Section 5, the interests in the general or Restricted (Exclusive Use) Common Areas; (viii) except as provided in Article VIII, Section 5, convertibility of Units into Common Areas or of Common Areas into Units; (ix) imposition of any right of first refusal or similar restriction on the right of a Unit Owner to sell, transfer, or otherwise convey his or her Unit; (x) any provisions which are for the express benefit of Mortgagees, Eligible Mortgage Holders, or eligible insurers or guarantors of first Mortgages on Units.

D. An addition or amendment to a Governing Document shall not be considered material if it is for the purpose of correcting technical errors, or for clarification only. An Eligible Mortgage Holder who receives a written request to approve additions or amendments who does not deliver or post to the requesting party a negative response within thirty (30) days shall be deemed to have approved such request.

#### **Section 6. Distribution of Insurance and Condemnation Proceeds:**

No Owner, or other party, shall have priority over any right of first Mortgagees of Units pursuant to their Mortgages in case of a distribution to Owners of insurance proceeds or condemnation awards for losses to or a taking of Units or any Common Area. Any provision to the contrary in this Declaration or in the By-Laws or other documents relating to the Project is to such extent void. All applicable fire and all physical loss or extended coverage insurance policies shall contain loss payable clauses acceptable to the affected Mortgagees naming the Mortgagees, as their interests may appear.

#### **Section 7. Notices to Mortgagees of Record:**

On any loss to any Unit covered by a Mortgage, if such loss exceeds Ten Thousand Dollars (\$10,000.00), or on any loss to the Common Area, if such loss exceeds Twenty Thousand Dollars (\$20,000.00), or any taking of such Common Areas, notice in writing of such loss or taking shall be given to each Mortgagee of record. If any Owner is in default under any provision of this Declaration, or the By-Laws, or the Rules adopted by the Association, which default is not cured within thirty (30) days after written notice to such Owner, the Association shall give to the Mortgagee of record of such Owner written notice of such default and of the fact that said thirty (30) day period has expired. The Mortgagee of record shall have the option, but not the obligation, to cure any default. Further, if any Unit and/or the Common Area is made the subject matter of any condemnation or eminent domain proceeding or is otherwise sought to be acquired by a condemning authority, then the first Mortgagee on such Unit shall be given timely written notice by the Association of such proceeding or proposed acquisition and the Mortgagee shall have the right, but not the obligation, to appear in any such proceeding.

**ARTICLE X - DAMAGE, DESTRUCTION OR  
CONDEMNATION OF COMMON AREA  
IMPROVEMENTS**

**Section 1. Damage and Destruction:**

In the event of damage or destruction of the Common Area or a Unit, or any part thereof, the Association shall have the responsibility to repair or replace the same in substantial accordance with the original plans and specifications of the Project.

**Subsection 1.1 Insured Losses:**

If the damage or destruction to the Common Area or a Unit is an insured loss the loss shall be handled as follows:

Minor Casualties: If the insurance proceeds initially offered or paid by the insurer do not exceed Fifty Thousand Dollars (\$50,000) such insurance proceeds shall be paid to the Association in accordance with Article IV, Section 1, Subsection 1.3 of this Declaration. The Board shall then contract to repair or rebuild the damaged portions of the Common Area or a Unit in substantial accordance with the original plans and specifications of the Project, obtain bids in accordance with the following paragraphs, and the insurance funds held by the Association shall be used for such reconstruction.

Major Casualty: If the insurance proceeds initially offered or paid by the insurer exceed Fifty Thousand Dollars (\$50,000), then:

1. All insurance proceeds shall be paid to the Association and deposited in a newly-created account, and held for the benefit of the Owner(s) of the relevant Unit and their Mortgagees as their respective interests may appear.
2. The Board shall obtain firm bids from two or more responsible contractors to rebuild the relevant portion of the Project in accordance with its condition prior to damage and destruction, modified at the direction of the Board to comply with the building codes and construction standard in effect at the time of the rebuilding. To be considered, any contractor's bid shall include the premium payable for a performance, labor and material payment bond from a reputable bonding company.
3. The Board shall then call a meeting of all Owners whose Units have been damaged to review all such submitted bids. A simple majority vote of these affected Owners will be required to accept or reject any bid. The failure by such Owners to either accept a bid or reject all bids shall authorize the Board to accept an unrejected bid it considers most favorable, or to seek further bids.

**Subsection 1.2 Uninsured or Insufficiently Insured Losses:**

If any damage or destruction is uninsured or if the insurance proceeds are insufficient to cover the cost of repairs or replacement of the property damaged or destroyed, the Board will make a special Assessment, in accordance with the provisions outlined in Article V, Section 3 of this Declaration, to cover such cost. Such special Assessment is in addition to any other regular Assessments and is subject to the rules herein relating to special Assessments. Any special Assessment for the rebuilding or major repair work of the structural Common Area housing

Units of the Project will be levied upon the basis of the ratio of the square footage of the Unit to be assessed to the total square footage of floor area of all Units to be assessed.

**Subsection 1.3 Full Insurance Settlement:**

Notwithstanding any provision of this Article X, if the insurance carrier offers the full amount required to repay and restore all of the damage, then the Board shall contract to repair or rebuild the damaged portions of all affected Units, in the manner provided in Article X, Subsection 1.1 for a minor casualty.

**Subsection 1.4 Emergency Repairs:**

Without waiting to obtain insurance settlements or bids, the Board may undertake such emergency repair work after a casualty as it may deem necessary or desirable under the circumstances, and the Board may charge the operating accounts of the Association for the cost thereof. In the event of a casualty, there is a substantial possibility that immediate emergency repairs will be required to eliminate defective or dangerous conditions and to comply with applicable laws, ordinances and regulation, pending settlement of insurance claims and prior to procuring bids for performance of restoration work.

**Subsection 1.5 Decision Not to Rebuild:**

The decision not to rebuild will require the affirmative vote or written assent of seventy-five percent (75%) of each class of Owners. Upon conversion of Class B membership to Class A membership as provided in this Declaration, the affirmative vote or written assent of seventy-five percent (75%) of the votes of Members other than the Grantor shall be required for the decision not to rebuild. In the event the membership elects not to rebuild, the proceeds received by the Association as a result of such decision shall be distributed by the Association among the Owners and their respective Mortgagees according to the respective fair market values of the Units at the time of destruction. The fair market value shall be determined by taking the average of two independent appraisals as commissioned by the Association.

**Section 2. Distribution of Funds in Event of Condemnation:**

A condemnation affecting all or part of the structural Common Area of the Project which is not apportioned among the Owners by a court judgment or by agreement between the condemning authority and each of the affected Owners, shall be distributed among the Owners and their respective Mortgagees according to the respective fair market values of the Units at the time of destruction. The fair market value shall be determined by taking the average of two independent appraisals as commissioned by the Association.

**ARTICLE XI - GENERAL PROVISIONS**

**Section 1. Enforcement of Bonded Obligations:**

When Common Area improvements have not been completed prior to the issuance of the first Final Public Report for the Project and the Association is obliged under a bond or other arrangement (hereinafter called "Bond") to secure performance of the commitment of Declarant to complete the improvements, the following provisions relative to the initiation of action to enforce the obligations of Declarant and the surety under the Bond shall pertain:

The Board shall consider and vote on the question of action by the Association to enforce the obligations under the Bond regarding any improvements for which a Notice of Completion

has not been filed within sixty (60) days after the completion date specified for that improvement in the Planned Construction Statement appended to the Bond. If the Association has given an extension in writing for the completion of any Common Area improvements, the Board shall be directed to consider and vote on the question if a Notice of Completion has not been filed within thirty (30) days after the expiration of any such extension.

There shall be a special meeting of the Members for the purpose of voting to override a decision by the Board not to initiate action to enforce the obligations under the Bond or on the failure of the Board to consider and vote on the question. The meeting shall be required to be held not less than thirty-five (35) nor more than forty-five (45) days after receipt by the Board of a petition for such a meeting signed by Members representing not less than five percent (5%) of the total voting power of the Association.

There shall be a vote by the Members other than Declarant at the special meeting called. A vote of the majority of the voting power of the Association residing in Members other than Declarant to take action to enforce the obligations under the Bond shall be deemed to be the decision of the Association and the Board shall thereafter implement this decision by initiating and pursuing appropriate action in the name of the Association.

#### **Section 2. Invalidity of any Provision:**

Should any provision or portion hereof be declared invalid or in conflict with any law of the jurisdiction where this Project is situated, the validity of all other provisions and portions hereof shall remain unaffected and in full force and effect.

#### **Section 3. Term:**

The covenants and restrictions of this Declaration shall run with and bind the Project, and shall inure to the benefit of and shall be enforceable by the Association or any Owner subject to this Declaration and his legal representatives, heirs, successors and assigns, for a term of thirty (30) years from the date this Declaration is recorded, after which time they shall be automatically extended for successive periods of ten (10) years, unless an instrument in writing, signed by a majority of the then Owners, has been recorded within the year preceding the beginning of any successive period of ten (10) years, agreeing to change said covenants and restrictions, in whole or in part, or to terminate the same.

#### **Section 4. Amendments:**

Except as otherwise stated herein, this Declaration may be amended only by the affirmative vote or written assent of seventy-five percent (75%) of each class of the Owners. Upon conversion of Class B membership to Class A membership as provided in this Declaration, the affirmative vote or written consent of seventy-five percent (75%) of the total voting power of the Association, and seventy-five percent (75%) of the votes of Members other than Declarant, shall be required for amendment of this Declaration. The percentage of voting power necessary to amend a specific clause or provision shall not be less than the percentage of affirmative votes prescribed for the action to be taken under that clause or provision. Any amendment must be recorded and shall become effective upon being recorded in the Official Records of the City and County of San Francisco, State of California.

#### **Section 5. Development Rights:**

Declarant is undertaking the work of developing for sale residential units and certain improvements with the Project. The completion of that work and the sale of said Units is essential to the establishment and welfare of the Property as a residential and commercial community. In order that this work may be completed and said Property be established as a fully occupied residential as rapidly as possible, nothing in this Declaration shall be understood or construed to:

A. Prevent Declarant, its contractors or subcontractors from obtaining reasonable access over and across the Common Area of the Project or from doing within any unsold Unit owned by it whatever is reasonably necessary or advisable in connection with the completion of said work;

B. Prevent Declarant or its representatives from erecting, constructing and maintaining within the Common Area such structures as may be reasonably necessary for completing said work and conducting its business of establishing said Property as a residential and commercial community and disposing of the same in parcels by sale, lease, or otherwise.

C. Prevent Declarant from maintaining such signs on Units still owned by Declarant or on the Common Area as may be necessary for the sale, lease or disposition of the Units therein; or

D. Prevent Declarant from maintaining model homes, sales offices, storage facilities or such related facilities in any unsold Units within the Project necessary or reasonable, in the opinion of Declarant, for sale or disposition of the Units. Declarant shall be entitled to reasonable use of the Common Areas and Common Area facilities for undertaking its sale of the Units.

#### **Section 6. Enforcement:**

Notwithstanding any other provision in this document:

A. Except as otherwise provided herein, the Association or any Owner shall have the right to enforce any and all of the covenants, conditions and restrictions now or hereafter imposed by this Declaration upon the Owners or upon any property within the Project; and

B. Any violation of any state, municipal or local law, ordinance or regulation pertaining to the ownership, occupation or use of any property within the Project is hereby declared to be a violation of this Declaration and subject to any or all of the enforcement procedures herein set forth; and

C. Each remedy provided by this Declaration is cumulative and not exclusive; and

D. The failure to enforce the provisions of any covenant, condition or restriction contained in this Declaration shall not constitute a waiver of any right to enforce any such provisions or any other provision here.

#### **Section 7. Alternative Dispute Resolution:**

This section shall only apply to disputes between the Association and an Owner (or two or more Owners) where (1) the amount in controversy is above \$7,500; and (2) the disputes do not concern the payment of delinquent Assessments and (3) disputes between the Association and Declarant or between Owners and Declarant in relation to defects in design or construction.

**(a) Mediation:**

If the Association and an Owner (or two Owners) or resident are unsuccessful at resolving any failure or alleged failure by an Owner or resident to comply with any provision of this Declaration (other than the provisions concerning Assessments), the By-Laws, or the Rules, the parties shall attempt in good faith to settle the dispute by nonbinding mediation before resorting to court action or binding arbitration. The neutral mediator shall have at least three (3) recent years of substantial experience mediating construction defect and other disputes arising out of condominium projects. Any party desiring mediation shall notify the other party(s) with whom he has a dispute of such desire, including within such notice the name and address of the neutral mediator, and a proposed time and date for the mediation. If any party so notified is unable to attend the mediation at the proposed date, time and place, he may arrange an alternative acceptable to all other parties provided the alternative date is within ten (10) days of the originally proposed date. All properly notified parties agree to appear for the mediation. Unless otherwise agreed by the parties, the costs of mediation shall be borne equally by the parties. Any party may petition a court of competent jurisdiction for an order compelling appearance at mediation.

**(b) Arbitration of Disputes:**

This provision shall only apply after the parties have attempted in good faith but failed to settle any dispute subject to subsection a. above by nonbinding mediation.

Any dispute or claim in law or equity arising out of the Project or the Governing Documents shall be decided by neutral binding arbitration by an experienced arbitrator with three (3) recent years of substantial experience deciding construction defect and other disputes arising out of condominium projects, and not by court action except as provided by California law for judicial review of arbitration proceedings. The parties shall have the right to discovery in accordance with Code of Civil Procedure Section 1283.05. At the hearing, any relevant evidence may be presented by any party and the formal rules of evidence applicable to judicial proceedings shall not govern. Evidence shall be admitted or excluded in the sole discretion of the arbitrator(s).

The arbitration shall proceed with due dispatch and a decision shall be rendered within 30 days after appointment of the arbitrator(s). The arbitrator(s)' decision shall be in writing and in a form sufficient for entry of a judgment in any court of competent jurisdiction in the State of California.

The arbitrator(s)' decision shall pertain, and shall be limited to, the granting of damages not to exceed any party's actual out-of-pocket expenses and the costs of undertaking any repairs, maintenance or reconstruction relating to the dispute and the award of any injunction or other equitable relief. In no event shall the arbitrator(s)' award include any component for punitive or exemplary damages. Costs of the arbitration proceeding shall be borne as determined by the arbitrators.

The following matters are excluded from arbitration hereunder: (a) a judicial or nonjudicial foreclosure or other action or proceeding to enforce a deed of trust, mortgage or real property sales contract as defined in Civil Code Section 2985; (b) an unlawful detainer action; (c) the filing or enforcement of a mechanic's lien; (d) any matter which is within the jurisdiction of a probate court or a small claims court; (e) an action for bodily injury or wrongful death; (f) an action or proceeding to enforce the obligation to pay Regular and Special Assessments, or a non-

judicial foreclosure to enforce a lien against a Unit; or (g) an action or proceeding to compel arbitration and/or mediation, including an action to impose sanctions for frivolous or bad faith activity designed to delay or frustrate arbitration and/or mediation. The filing of a judicial action to enable the recording of a notice of pending action, for order of attachment, receivership, injunction, or other provisional remedies, shall not constitute a waiver of the right to arbitrate under this provision.

**Section 8. Claims Under \$7,500 and Court Actions for Injunctive or Declaratory Relief:**

(a) Where there is contemplated court actions by the Association or any Owner or resident for (1) declaratory relief to interpret or enforce the Governing Documents; (2) injunction relief to interpret or enforce the Governing Documents; or (3) a claim for damages in the amount of \$7,500 or less coupled with either a claim for declaratory or for injunctive relief to interpret or enforce the Governing Documents, the following rules shall apply:

(b) Section 8 of this Article XI does not apply to any court action by the Association for nonpayment of delinquent Assessments. Section 8 shall not apply under circumstances where the Association or Owner who desires to initiate such action ("Complaining Party") is entitled to a temporary restraining order or preliminary injunction in order to avoid irreparable harm or injury or where the applicable time limitation for commencing the action would run within 120 days.

(c) Before initiating any court action against an Owner or resident pursuant to subsection(a) of this Section 8, the Complaining Party shall first comply with the provisions of Civil Code §1354, or a comparable superseding statute, relating to alternative dispute resolution. The procedures described in paragraph (d), below, are intended to satisfy the Civil Code Section 1354 alternative dispute resolution requirements and all notices issued and procedures followed in the alternative dispute resolution process shall comply with the specific requirements imposed by Civil Code §1354.

(d) For claims subject to this section, the parties shall endeavor, as provided in Section 7 of Article XI, to submit their dispute to a form of alternative dispute resolution such as mediation or arbitration. The form of alternative dispute resolution chosen may be binding or non-binding at the option of the parties. Any party to such a dispute may initiate this process by serving on another party to the dispute a Request for Resolution. The Request for Resolution shall include (1) a brief description of the dispute between the parties; (2) a request for alternative dispute resolution; and (3) a notice that the party receiving the Request for Resolution is required to respond thereto within thirty (30) days of receipt or it will be deemed rejected. Service of the Request for Resolution shall be in the same manner as prescribed for service in a small claims action as provided in Section 116.340 of the Code of Civil Procedure. Parties receiving a Request for Resolution shall have 30 days following service of the Request for Resolution to accept or reject alternative dispute resolution and, if not accepted within the 30-day period by a party, shall be deemed rejected by that party. If alternative dispute resolution is accepted by the party upon whom the Request for Resolution is served, the alternative dispute resolution shall be completed within ninety (90) days of receipt of the acceptance by the party initiating the Request for Resolution, unless extended by written stipulation signed by both parties. In arbitration, the costs of the alternative dispute resolution shall be borne by the parties in a manner to be determined by the arbitrator.

(e) At the time of filing a civil action by either the Association or an Owner solely for declaratory relief or injunctive relief, or for declaratory relief or injunctive relief in conjunction with a claim for monetary damages, other than Association Assessments, for seventy-five hundred dollars (\$7,500) or less, related to the enforcement of the Governing Documents, the party filing the action shall file with the complaint a certificate stating that alternative dispute resolution has been completed in compliance with subdivision (e). The failure to file a certificate as required by this subdivision (e) shall be grounds for a demurrer pursuant to Section 430.10 of the Code of Civil Procedure or a motion to strike pursuant to Section 435 of the Code of Civil Procedure unless the filing party certifies in writing that one of the other parties to the dispute refused alternative dispute resolution prior to the filing of the complaint, that preliminary or temporary injunctive relief is necessary or that alternative disputed resolution is not required by subdivision (a), because the limitation period for bringing the action would have run within the 120-day period next following the filing of the action, or the court finds that dismissal of the action for failure to comply with subdivision (a) would result in substantial prejudice to one of the parties.

(f) Once a civil action specified in subdivision (b) to enforce the Governing Documents has been filed by either an Association or an Owner, upon written stipulation of the parties the matter may be referred to alternative dispute resolution and stayed. During this referral, the action shall not be subject to the rules implementing subdivision (c) of Section 68603 of the Government Code.

(g) Members shall annually be provided a summary of the provisions of this section, which specifically references this section. The summary shall include the following language:

“Failure by any Member of the Association to comply with the prefiling requirements of Section 1354 of the Civil Code may result in the loss of your rights to sue the Association or another Member of the Association regarding enforcement of the Governing Documents.”

The summary shall be provided either at the time the pro forma budget required by Section 1365 is distributed or in the manner specified in Section 5016 of the Corporations Code.

(h) Any Request for Resolution sent to any Owner pursuant to subdivision (d) shall include a copy of this section.

### **Section 9. Notice of Civil Actions; Meeting:**

Not later than thirty (30) days prior to the filing by the Association of any civil action against Declarant, the Board shall comply with notification to the Owners of the requirements set forth in Section 1368.4 of the California Civil Code.

### **Section 10. [Intentionally Deleted]**

### **Section 11. Alternative Dispute Resolution:**

This section shall only apply to disputes where (1) the amount in controversy is above \$7,500; and (2) the disputes do not concern the payment of delinquent assessments. This section shall not apply to disputes where the amount in controversy is \$7,500 or less, which disputes are subject to the provisions of Article XI, Section 8 of this Declaration. This subsection shall not apply to disputes regarding the payment of delinquent assessments, which disputes are subject to the provisions of Article V, Section 6, Subsections 6.1 - 6.4 of this Declaration.

**(a) MEDIATION:**

If the Association and an Owner (or two Owners) or resident are unsuccessful at resolving any failure or alleged failure by an Owner or resident to comply with any provision of this Declaration (other than the provisions concerning assessments), the Bylaws and the Rules the parties shall attempt in good faith to settle the dispute by nonbinding mediation before resorting to court action or binding arbitration. The neutral mediator shall have at least three (3) recent years of substantial experience mediating construction defect and other disputes arising out of condominium projects. Any party desiring mediation shall notify the other party(s) with whom he has a dispute of such desire, including within such notice the name and address of the neutral mediator, and a proposed time and date for the mediation. If any party so notified is unable to attend the mediation at the proposed date, time and place, he may arrange an alternative acceptable to all other parties provided the alternative date is within ten (10) days of the originally proposed date. All properly notified parties agree to appear for the mediation. Unless otherwise agreed by the parties, the costs of mediation shall be borne equally by the parties. Any party may petition a court of competent jurisdiction for an order compelling appearance at mediation.

**(b) ARBITRATION OF DISPUTES:**

This provision shall only apply after the parties have attempted in good faith but failed to settle any dispute subject to subsection (a) above by nonbinding mediation.

Any dispute or claim in law or equity arising out of the CC&R's or other Governing Documents shall be decided by neutral binding arbitration by an experienced arbitrator with three (3) recent years of substantial experience deciding disputes arising out of condominium projects, and not by court action except as provided by California law for judicial review of arbitration proceedings. The arbitration shall be initiated by written notice to the other party, setting forth in general terms the nature of the dispute and the relief claimed, and nominating two (2) arbitrators qualified pursuant to this subsection (b). The party receiving the notice shall nominate two arbitrators qualified pursuant to this subsection (b). Within seven (7) days of receipt of all four names, the parties, either personally or through their attorneys, shall choose one of the four (4) nominated arbitrators to arbitrate the dispute. Any arbitrator so nominated shall use the procedures set forth in the current version of the American Arbitration Association's Commercial Rules. In selecting the arbitrator, the provisions of Section 1297.121 of the Code of Civil Procedure shall apply. An arbitrator may be challenged for any of the grounds listed therein or in Section 1297.124 of the Code of Civil Procedure. If the parties are unable to agree on an arbitrator, then either or both the parties shall petition a court of competent jurisdiction to choose one of the four nominated arbitrators, or, if all four nominated arbitrators have conflicts of interest, to appoint a neutral arbitrator qualified pursuant to this subsection (b). The parties shall have the right to discovery in accordance with Code of Civil Procedure Section 1283.05. At the hearing, any relevant evidence may be presented by any party and the formal rules of evidence applicable to judicial proceedings shall not govern. Evidence shall be admitted or excluded in the sole discretion of the arbitrator. The arbitration shall proceed with due dispatch and a decision shall be rendered within 30 days after appointment of the arbitrator(s). The arbitrator(s)' decision shall be in writing and in a form sufficient for entry of a judgment in any court of competent jurisdiction in the State of California.

The arbitrator(s)' decision shall pertain, and shall be limited to, the granting of damages not to exceed any party's actual out-of-pocket expenses and the costs of undertaking any repairs, maintenance or reconstruction relating to the dispute and the award of any injunction or other equitable relief. In no event shall the arbitrator(s)' award include any component for punitive or exemplary damages. Costs of the arbitration proceeding shall be borne as determined by the arbitrators.

The following matters are excluded from arbitration hereunder: (a) a judicial or nonjudicial foreclosure or other action or proceeding to enforce a deed of trust, mortgage or real property sales contract as defined in Civil Code Section 2985; (b) an unlawful detainer action; (c) the filing or enforcement of a mechanic's lien; (d) any matter which is within the jurisdiction of a probate court or a small claims court; (e) an action for bodily injury or wrongful death; (f) an action or proceeding to enforce the obligation to pay Regular and Special Assessments, or a non-judicial foreclosure to enforce a lien against a Unit; or (g) an action or proceeding to compel arbitration and/or mediation, including an action to impose sanctions for frivolous or bad faith activity designed to delay or frustrate arbitration and/or mediation. The filing of a judicial action to enable the recording of a notice of pending action, for order of attachment, receivership, injunction, or other provisional remedies, shall not constitute a waiver of the right to arbitrate under this provision.

**Section 12. Claims Under \$7,500 and Court Actions for Injunctive or Declaratory Relief:**

(a) Section 8 of this Article XI applies only to court actions by the Association or any Owner or resident for (1) declaratory relief to interpret or enforce the Governing Documents; (2) injunction relief to interpret or enforce the Governing Documents; or (3) a claim for damages in the amount of \$7,500 or less coupled with either a claim for declaratory or for injunctive relief to interpret or enforce the Governing Documents.

(b) Section 8 of this Article XI does not apply to any court action by the Association for nonpayment of delinquent Assessments. Section 8 shall not apply under circumstances where the Association or Owner who desires to initiate such action ("Complaining Party") is entitled to a temporary restraining order or preliminary injunction in order to avoid irreparable harm or injury or where the applicable time limitation for commencing the action would run within 120 days.

(c) Before initiating any court action against an Owner or resident pursuant to subsection (a) of this Section 8, the Complaining Party shall first comply with the provisions of Civil Code §1354, or a comparable superseding statute, relating to alternative dispute resolution. The procedures described in paragraph (d), below, are intended to satisfy the Civil Code Section 1354 alternative dispute resolution requirements and all notices issued and procedures followed in the alternative dispute resolution process shall comply with the specific requirements imposed by Civil Code §1354.

(d) For claims subject to this section, the parties shall endeavor, as provided in Section 7 of this Article XI, to submit their dispute to a form of alternative dispute resolution such as mediation or arbitration. The form of alternative dispute resolution chosen may be binding or non-binding at the option of the parties. Any party to such a dispute may initiate this process by serving on another party to the dispute a Request for Resolution. The Request for Resolution shall include (1) a brief description of the dispute between the parties; (2) a request for alternative dispute resolution; and (3) a notice that the party receiving the Request for Resolution

is required to respond thereto within thirty (30) days of receipt or it will be deemed rejected. Service of the Request for Resolution shall be in the same manner as prescribed for service in a small claims action as provided in Section 116.340 of the Code of Civil Procedure. Parties receiving a Request for Resolution shall have 30 days following service of the Request for Resolution to accept or reject alternative dispute resolution and, if not accepted within the 30-day period by a party, shall be deemed rejected by that party. If alternative dispute resolution is accepted by the party upon whom the Request for Resolution is served, the alternative dispute resolution shall be completed within ninety (90) days of receipt of the acceptance by the party initiating the Request for Resolution, unless extended by written stipulation signed by both parties. The costs of the alternative dispute resolution shall be borne by the parties.

(e) At the time of filing a civil action by either the Association or an Owner solely for declaratory relief or injunctive relief, or for declaratory relief or injunctive relief in conjunction with a claim for monetary damages, other than Association Assessments, for five thousand dollars (\$5,000) or less, related to the enforcement of the Governing Documents, the party filing the action shall file with the complaint a certificate stating that alternative dispute resolution has been completed in compliance with subdivision (e). The failure to file a certificate as required by this subdivision (e) shall be grounds for a demurrer pursuant to Section 430.10 of the Code of Civil Procedure or a motion to strike pursuant to Section 435 of the Code of Civil Procedure unless the filing party certifies in writing that one of the other parties to the dispute refused alternative dispute resolution prior to the filing of the complaint, that preliminary or temporary injunctive relief is necessary or that alternative disputed resolution is not required by subdivision (a), because the limitation period for bringing the action would have run within the 120-day period next following the filing of the action, or the court finds that dismissal of the action for failure to comply with subdivision (a) would result in substantial prejudice to one of the parties.

(f) Once a civil action specified in subdivision (b) to enforce the Governing Documents has been filed by either an Association or an Owner, upon written stipulation of the parties the matter may be referred to alternative dispute resolution and stayed. The costs of the alternative dispute resolution shall be borne by the parties. During this referral, the action shall not be subject to the rules implementing subdivision (c) of Section 68603 of the Government Code.

(g) Members shall annually be provided a summary of the provisions of this section, which specifically references this section. The summary shall include the following language:

“Failure by any Member of the Association to comply with the prefiling requirements of Section 1354 of the Civil Code may result in the loss of your rights to sue the Association or another Member of the Association regarding enforcement of the Governing Documents.”

The summary shall be provided either at the time the pro forma budget required by Section 1365 is distributed or in the manner specified in Section 5016 of the Corporations Code.

(h) Any Request for Resolution sent to any Owner pursuant to subdivision (d) shall include a copy of this section.

### **Section 13. Notice of Civil Actions; Meeting:**

Not later than thirty (30) days prior to the filing by the Association of any civil action against Declarant, the Board shall comply with notification to the Owners of the requirements set forth in Section 1368.4 of the California Civil Code.

**Section 14. Alternative Dispute Resolution Involving Claims Between the Association and the Declarant and Any Owner:**

This Section shall apply only to disputes between the Association and any Owner and the Declarant arising from or relating to alleged deficiencies in the design or construction of the Project.

**Subsection 14.1 Waiver of a Trial By a Jury:**

THIS SECTION 14.1 CONTAINS ALTERNATIVE DISPUTE RESOLUTION PROCEDURES THAT INCLUDE A WAIVER OF A TRIAL BY JURY. YOU ARE ADVISED TO READ THESE PROCEDURES CAREFULLY AND CONSULT WITH LEGAL COUNSEL IF YOU HAVE ANY QUESTIONS.

This Section describes the procedures for filing claims against Declarant and certain other designated parties related to this Project. Unless the context indicates otherwise, the definitions set forth in Article 1 of the Declaration shall apply in this Section.

Any claim, dispute or other controversy between the Association and/or any Owner(s) and the Declarant or any director, officer, shareholder, partner, employee or agent of the Declarant or any contractor, subcontractor, design professional, engineer or other person that provided materials, labor or other services to the Project (collectively the "Declarant" for purposes of this Section), the use or condition of any Unit, and/or the design, specifications, surveying, grading, construction, installation and/or operation of any improvements or landscaping located thereon, including but not limited to any claims for violation of the construction standards (the "Functionality Standards") set forth in Civil Code sections 896 and 897, whether based in contract, tort or statute violation, (individually and collectively the "Claim") shall be subject to the Claim procedures set forth in Sections 1 and 2 of this Section.

It is intended that the procedures in this Section become operative only if the Claim cannot be resolved in accordance with Declarant's normal customer service procedures; provided however, a Claim may be filed under the provisions in this Section without complying with Declarant's normal customer service procedures.

Declarant, the Association and each Owner covenant not to commence any litigation without complying with the procedures described in Sections 14.1 and 14.2. If any party breaches the foregoing, the other party may obtain an appropriate order compelling the breaching party to comply with the procedures. Except as is expressly authorized by law, nothing herein shall reduce or extend any applicable time frame within which legal action must be commenced, including applicable statutes of limitation or repose and time frames set forth in Civil Code Sections 896, 897 and 941.

Title 7 of Part 2 of Division 2 of the Civil Code (Civil Code sections 895 through 945.5) commonly known as "SB 800" sets forth functionality standards that describe how the improvements and landscaping within this Development should function during certain applicable time periods (the "Functionality Standards"). SB 800 impacts the legal rights of the Association and each Owner. Civil Code sections 910 through 938 contain prelitigation procedures that Declarant may elect to use or Declarant may elect to use. Declarant's election is set forth in Section 1. The Association and Owner have certain rights under SB 800 if the improvement or landscaping fails to meet a Functionality Standard during the applicable time

period. These rights may be lost as described in Civil Code Section 945.5, including if the Association or Owner: (1) fails to follow the Declarant's or the manufacturer's reasonable recommendations regarding inspection and maintenance, including schedules; (2) fails to follow the home maintenance guidelines; (3) fails to provide Declarant with timely notice after a discovery of the violation of the Functionality Standard or to allow Declarant reasonable and timely access for repairs; or (4) unreasonably fails to minimize or prevent damages in a timely manner.

#### **Subsection 14.2 Nonadversarial Prelitigation Procedures:**

If the Association or an Owner (the "Claimant") elects to make a Claim, including any Claim for violation of the standards set forth in Civil Code sections 896 or 897, the Claim shall be subject to the nonadversarial prelitigation procedures set forth in this Section 14.2. Civil Code sections 910 through 938 set forth certain nonadversarial prelitigation procedures for the resolution of claims made for violation of the standards under Civil Code Sections 896 or 897. As authorized by Civil Code section 914, Declarant has elected not to use these procedures and to use instead the alternative nonadversarial prelitigation procedures set forth in this Section 14.2. The Claimant shall notify Declarant in writing of the Claim pursuant to the Claim notice requirements in Section 14.3 of this Section. The notice shall: (i) contain the Claimant's name and address, (ii) state that the Claimant elects to commence the procedures described below to resolve the Claim; and (iii) describe the nature and location of the Claim in reasonable detail (the "Claim Notice"). The Claim is subject to the following nonadversarial prelitigation procedures:

(i) Notice, Right to Inspect, and Right to Corrective Action. Within 90 days of Declarant's receipt of the Claim Notice, the Claimant and Declarant's representatives shall meet at the Claimant's Property to discuss the Claim. At such meeting or at such other mutually-agreeable time, Declarant's representatives shall have full access to the Project for the purposes of inspecting the Project and investigating the Claim. The parties shall negotiate in good faith in an attempt to resolve the Claim. If the Claimant and Declarant cannot agree on the validity of the Claim, the corrective action needed, the party to take the corrective action or any other matter related to the Claim within 90 days of Declarant's receipt of the Claim Notice or such longer time as may be mutually acceptable to the Claimant and Declarant, either party may commence the mediation procedures described in Section 2(ii) below. If the parties agree on any corrective action, Declarant's representatives shall be provided full access to the Project to take and complete corrective action. Declarant shall commence the corrective work no later than 90 days following the Claimant's acceptance of the proposed corrective action, and shall use commercially reasonable efforts to complete the work within 180 days. If Declarant fails to respond to the Claim Notice or fails to meet with the Claimant within the time period required herein, the Claimant is released from any further obligation to comply with the nonadversarial procedures in this Section 2 and may proceed to initiate the binding adversarial procedures in Section 3.

(ii) Mediation. If the Claim is not resolved in accordance with the procedures described in Section 2(i) and except as otherwise provided in Section 2(i), either the Claimant or the Declarant may submit the Claim to mediation under the mediation procedures adopted by the Judicial Arbitration and Mediation Services ("JAMS") or any successor thereto or to any other entity offering mediation services that is acceptable to the Claimant and the Declarant. The parties shall cooperate so that the mediation hearing can be held as soon as practicable. If the mediation hearing cannot take place within 120 days of Declarant's receipt of the Claims Notice

or such later date as may be acceptable to Claimant and Declarant, the parties are released from any further obligation under this Section 2(ii) and either party may proceed to initiate the binding adversarial procedures described in Section 3 of this Section.

Each party shall bear their own mediation expenses provided that the initial mediation administrative fee and the mediator's fee for a maximum of two hours shall be borne by Declarant and thereafter equally by the parties unless they agree otherwise. Any party to the mediation may at anytime after a minimum of four hours of mediation terminate the mediation by notifying the other parties and the mediator and proceed to the binding adversarial procedures described in Section 3 of this Section.

No person shall serve as a mediator who has any financial or personal interest in the result of the mediation, except by the written consent of all parties. Prior to accepting any appointment, the prospective mediator shall disclose any circumstances likely to create a presumption of bias or prevent a prompt commencement of the mediation process.

Each party shall submit a brief memorandum setting forth its position with regard to the issues that need to be resolved within ten days of the selection of the mediator or within such time frame established by the mediator. The mediation shall be commenced within ten days following the submittal of the memoranda. The mediation shall be held in the county in which the Project is located or such other place as is mutually acceptable to the parties.

The mediator has discretion to conduct the mediation in the manner in which the mediator believes is most appropriate for reaching a settlement of the Claim. The mediator is authorized to conduct joint and separate meetings with the parties and to make oral and written recommendations for settlement. Whenever necessary, the mediator may also obtain expert advice concerning technical aspects of the Claim, provided the parties agree and assume the expenses of obtaining such advice. The mediator does not have the authority to impose a settlement on the parties.

The mediation shall be subject to the provisions of Evidence Code sections 1115 through 1128, or any successor statutes thereto, except as the parties may agree otherwise in writing or orally in accordance with the requirements of Evidence Code section 1118.

Persons other than the parties, the representatives and the mediator may attend mediation sessions only with the permission of the parties and the consent of the mediator. Confidential information disclosed to a mediator by the parties or by witnesses in the course of the mediation shall not be divulged by the mediator. All records, reports, or other documents received by the mediator while serving in such capacity shall be confidential. There shall be no stenographic record of the mediation process.

If the Claim is not resolved in accordance with these nonadversarial prelitigation procedures, the Claim shall be resolved in accordance with the binding adversarial procedures set forth in Section 3 of this Section.

#### **Subsection 14.3 Binding Adversarial Procedures:**

If Claimant and Declarant cannot resolve the entire Claim in accordance with the procedures in Section 2 of this Section or if corrective action is undertaken by Declarant and the parties disagree on the adequacy of the corrective action or any other claims arising from

the corrective action, the portion of the Claim not resolved, including any unresolved claims arising out of the corrective action undertaken by Declarant or Declarants agents, shall be resolved in accordance with the following binding adversarial procedure.

Either party may commence binding arbitration by submitting the Claim to Judicial Arbitration and Mediation Services ("JAMS") for resolution under the JAMS commercial arbitration rules, or to any other entity offering mediation services that is acceptable to the Claimant and to Declarant. The arbitration will be heard by a single arbitrator unless the Claimant and Declarant otherwise agree in writing. The Claimant and Declarant each waives the right to a jury trial.

The Association, each Owner and Declarant acknowledge and agree that any Claim involving the design, specification, surveying, grading, construction, installation or operation of any Improvement or landscaping within the Project, including any Claim under Civil Code Sections 896 and 897, involves interstate commerce and is subject to and governed by the Federal Arbitration Act, notwithstanding any State or local laws or ordinances to the contrary and notwithstanding the fact the parties have elected to utilize certain State law arbitration procedures to resolve the Claim. The following provisions and procedures shall apply in all cases unless the parties agree otherwise in writing:

(i) the proceedings shall be heard in the County in which the Project is located;

(ii) the matter shall be heard by a single arbitrator who shall be a retired judge or attorney with at least five years experience in real estate construction defect matters;

(iii) the fee to initiate the arbitration shall be paid by the Declarant and the arbitrator's fees shall be borne equally by Declarant and the Claimant, unless Declarant agrees in writing to advance the arbitrator's fees, provided that arbitration costs and fees, including any initiation fee and the arbitrator's fees, ultimately shall be borne as determined by the arbitrator;

(vi) each party shall bear its own attorneys' fees and costs (including expert costs) for the arbitration;

(v) the arbitrator shall be appointed within 60 days of the administrator's receipt of a written request to arbitrate the dispute. In selecting the arbitrator, the provisions of section 1297.121 of the Code of Civil Procedure shall apply. The arbitrator appointed to serve shall be a neutral and impartial individual. The arbitrator may be challenged for any of the grounds listed therein or in section 1297.124 of the Code of Civil Procedure;

(vi) the arbitrator may require one or more pre-hearing conferences;

(vii) the parties shall be entitled to discovery to the extent allowed by section 1283.05 of the Code of Civil Procedure;

(viii) the arbitrator shall be authorized to provide all recognized remedies available in law or equity;

(ix) the arbitrator in his or her discretion may award costs (including the initiation fee and the arbitrator's fees) and/or attorneys' fees to the party that the arbitrator determines was the prevailing party;

(x) the arbitrator's decision shall be final and binding on the parties unless corrected or validated under the grounds authorized in Code of Civil Procedure section 1286.2 or 1286.6; and,

(xi) The arbitrator's decision maybe enforced in any court of competent jurisdiction.

If any provision of this Section 3 shall be determined to be unenforceable or to have been waived, the remaining provisions shall be deemed to be severable therefrom and enforceable according to their terms.

Notwithstanding anything to the contrary, if any party determines in good faith that not all necessary and appropriate parties, including, but not limited to, contractors, subcontractors, design professionals, and/or material suppliers, will participate in the arbitration in order to accomplish a complete and final resolution of the Claim, this party shall notify the other party or parties in writing identifying the parties that will not participate; and thereafter all parties to the Claim shall be released from any obligation to participate in the arbitration, and any party may file a lawsuit in any court of competent jurisdiction to resolve the Claim.

#### **Subsection 14.4 Agent for Services of Claim Notice:**

Notice of any Claim made, including Civil Code Section 896 and 897 claims, or requests for information including requests for copies of the documents described in Section 5 or for copies of the documents described in Sections 1 through 4, may be served on Declarant's agent via certified mail, overnight mail or personal delivery. The name and address of Declarant's agent for this purpose is:

MSPDI Turk, LLC,  
2370 Market Street, Suite 458  
San Francisco, CA 94114

If the notice cannot be served on Declarant's agent at the above-referenced address because the agent is no longer located at the address or the agent has changed and Declarant has not provided the Claimant with an updated address or the name and/or address of the new agent, the Claimant may serve the claim notice on Declarant's agent for notice under Civil Code Section 912(e) on file with the California Secretary of State's Office in Sacramento, California. The current telephone numbers and website for the Secretary of State's Office are: (916) 657-5448 or (916) 653-3984 and [www.ss.ca.gov](http://www.ss.ca.gov). Written request can be mailed to the California Secretary of State, Special Filings, P.O. Box 942877, Sacramento, California, 94277-0001.

If the Claim notice is served via mail, it shall be assumed received by Declarant on the third business day following deposit into the U.S. Mails. If delivered via overnight mail, such as Federal Express or UPS, it shall be assumed received on the next business day. If delivered personally, it shall be assumed received on the date of personal delivery. These assumptions may be rebutted by Declarant if Declarant did not receive actual notice.

#### **Subsection 14.5 Documents and Subsequent Owners:**

Declarant has or will provide copies of certain documents to the initial purchasers of homes in this Development:

- (a) The Bylaws and Articles of Incorporation of the Homeowners Association;
- (b) The Budget of the Association;
- (c) The Declaration of Covenants, Conditions and Restrictions;
- (d) The Disposition and Development Agreement or Owner Participation Agreement;
- (e) Smoke Detector Statement of Compliance;
- (f) Americans with Disabilities Act Supplement;
- (g) Homeowners Guide to Earthquake Safety & Environmental Hazards Booklet & Receipt;
- (h) Notice of Prelitigation Procedure;
- (i) Disclosure Statement Pursuant to Civil Code Section 1102;
- (j) Natural Hazard Disclosure Statement;
- (k) Proposition 65 Disclosure;
- (l) Homeowners' Association Rules & Regulations;
- (m) Homeowners' Association Move-in/out Policies.

The initial purchasers shall retain the foregoing documents (the "Documents") and on transfer of title to a subsequent owner shall transfer the Documents or provide true and complete copies to the new owner(s) on or before transfer of title and instruct the new owner(s) that they are to retain the Documents and transfer or provide copies to any subsequent owner(s). Replacement copies of the Documents may be obtained from Declarant by contacting Declarant at Declarant's principal place of business or through the agent for claim notice purposes described in Section 4 of this Section. Declarant may charge a reasonable fee for providing replacement copies. Initial purchasers and subsequent owners, must comply with the inspection and maintenance guidelines provided by the Declarant and any manufacturer.

#### **Subsection 14.6 Covenants:**

The covenants, restrictions, rights, duties, benefits and burdens benefit and bind each Unit and each Owner and successive Owner thereto as covenants running with the land and equitable servitudes and pursuant to the authority of Civil Code Section 945.

#### **Subsection 14.7 Amendments:**

Notwithstanding anything in the Declaration to the contrary: (i) the provisions in this Section may not be modified or waived without the prior written consent of Declarant; (ii) the provisions in this Section may be modified or waived with respect to any particular Claim with the written consent of Declarant and the Claimant or Claimants that made the Claim. The Board of Directors shall have full power and authority to approve any modifications or waivers with Declarant with respect to any Claim made by the Association.

**Subsection 14.8 Claims Filing Period:**

Nothing herein extends any time periods in which a claim or action must be filed under Civil Code Sections 896 or 897 or otherwise extends any applicable statutes of limitations or statutes of repose, except as expressly authorized by law.

**Section 15. Fair Housing:**

No Owner shall, either directly or indirectly, forbade or restrict the conveyance, encumbrance, leasing or mortgaging, or occupancy of his Unit to any person for reasons of race, color, religion, sex, sexual orientation, marital status, national origin, ancestry or adulthood of any vendee, lessee or occupant.

IN WITNESS WHEREOF, the undersigned, being the Declarant herein, has executed this Declaration this 11 day of April, 2012.

MSPDI TURK, LLC,

A California limited liability company

By: Michael Simmons Property

Development, Inc.,

A California corporation

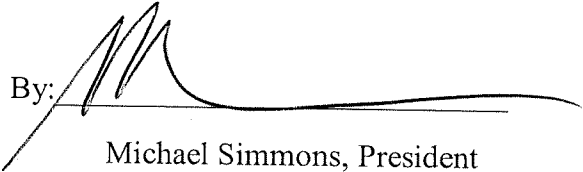
By:   
Michael Simmons, President

**[ALL SIGNATURES MUST BE ACKNOWLEDGED]**

**ACKNOWLEDGEMENT**

SEE ATTACHED CERTIFICATE  
DATE 4/11/12 NOTARY INITIALS ASK

CALIFORNIA ALL-PURPOSE ACKNOWLEDGMENT

CIVIL CODE § 1189

State of California

County of San Francisco

On 4/11/12 before me, Adam G. Keim, Notary Public

personally appeared Michael Simmons

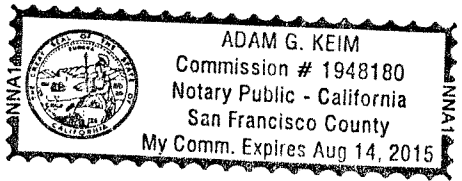

who proved to me on the basis of satisfactory evidence to be the person(s) whose name(s) is/are subscribed to the within instrument and acknowledged to me that he/she/they executed the same in his/her/their authorized capacity(ies), and that by his/her/their signature(s) on the instrument the person(s), or the entity upon behalf of which the person(s) acted, executed the instrument.

I certify under PENALTY OF PERJURY under the laws of the State of California that the foregoing paragraph is true and correct.

WITNESS my hand and official seal.

Signature: [Handwritten Signature]

Place Notary Seal Above

OPTIONAL

Though the information below is not required by law, it may prove valuable to persons relying on the document and could prevent fraudulent removal and reattachment of this form to another document.

Description of Attached Document

Title or Type of Document: Declaration of Covenants, Conditions and Restrictions
Document Date: 4/11/12
Number of Pages: 72 project

Signer(s) Other Than Named Above: N/A

Capacity(ies) Claimed by Signer(s)

- Signer's Name:
Corporate Officer - Title(s):
Individual
Partner - Limited General
Attorney in Fact
Trustee
Guardian or Conservator
Other:

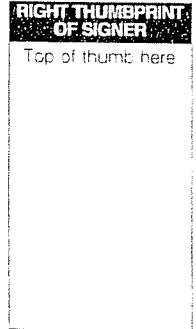

- Signer's Name:
Corporate Officer - Title(s):
Individual
Partner - Limited General
Attorney in Fact
Trustee
Guardian or Conservator
Other:

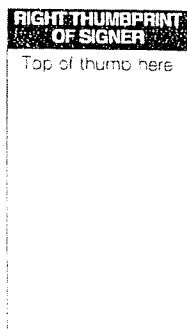

Signer Is Representing:

Signer Is Representing:

## **EXHIBIT A**

### **LEGAL DESCRIPTION**

All that certain real property, as shown on that certain map entitled, "Final Map No. 5914, a 32 Unit Residential Condominium Project", which Map was filed for record in the Office of the Recorder of the City and County of San Francisco, State of California on November 22, 2011 in Book 117 of Condominium Maps at Pages 51 to 53, inclusive.

**Exhibit B**  
**CONDOMINIUM PLAN**

**EXHIBIT "B"**  
**A RESIDENTIAL CONDOMINIUM PLAN FOR**  
**1345 TURK STREET**  
SAN FRANCISCO, CALIFORNIA  
ASSESSOR'S BLOCK 0756, LOT 017

BEING ALL THAT CERTAIN REAL PROPERTY IN THE CITY AND COUNTY OF SAN FRANCISCO, STATE OF CALIFORNIA, AS SHOWN ON THAT CERTAIN MAP ENTITLED "FINAL MAP NO. 5914", FILED FOR RECORD ON NOVEMBER 22, 2011, IN BOOK 117 OF CONDOMINIUM MAPS, PAGES 51 THROUGH 53, ON FILE IN THE OFFICE OF THE RECORDER OF THE CITY AND COUNTY OF SAN FRANCISCO.

**SURVEYOR'S STATEMENT:**

I, THE UNDERSIGNED, HEREBY STATE THAT I AM A LICENSED LAND SURVEYOR IN THE STATE OF CALIFORNIA, AND THIS CONDOMINIUM PLAN CONSISTING OF 24 SHEETS WAS PREPARED UNDER MY SUPERVISION AND THAT THIS PLAN TRULY REPRESENTS THE BOUNDARIES AND ELEVATIONS OF THE PARCELS AND COMMON AREA. I ALSO STATE THE SURVEY MADE UNDER MY DIRECTION DURING THE MONTH OF MARCH 2012, IS TRUE AND COMPLETE AS SHOWN.



*Frederick T. Seher*

FREDERICK T. SEHER  
LICENSED LAND SURVEYOR NO. 6216  
EXPIRATION DATE: MARCH 31, 2014

04-11-12

DATE:

**GENERAL NOTES:**

1. THE SUBDIVISION DEPICTED HEREON IS SUBJECT TO THE PROVISIONS OF THE DAVIS-STIRLING COMMON INTEREST DEVELOPMENT ACT.
2. **UNIT.** A UNIT CONSISTS OF THE AREA BOUNDED BY THE INTERIOR UNFINISHED SURFACES OF ITS PERIMETER WALLS, BEARING WALLS, FLOORS, FIREPLACES, CEILINGS, WINDOWS AND INTERIOR PORTIONS OF WINDOW FRAMES AND TRIM, DOORS (INCLUDING WINDOWS IN DOORS) AND INTERIOR PORTIONS OF DOOR FRAMES AND TRIM; INCLUDING BOTH THE PORTIONS OF THE BUILDING SO DESCRIBED AND THE AIRSPACE SO ENCOMPASSED. A UNIT INCLUDES (I) THE WALLBOARD, PLASTER AND PAINT ON ALL INTERIOR SURFACES LOCATED OR EXPOSED WITHIN THE UNIT, (II) WINDOW SASHES OR OTHER ELEMENTS THAT DIRECTLY CONTACT THE GLASS PORTION OF THE WINDOW, (III) DOOR AND WINDOW HARDWARE AND ALL MECHANICAL ELEMENTS OF DOORS AND WINDOWS, (IV) PLUMBING, HEATING, AIR CONDITIONING AND ELECTRICAL FIXTURES OR APPLIANCES LOCATED OR EXPOSED WITHIN THE UNIT, AND (V) WATER HEATERS, FURNACES OR AIR CONDITIONERS SERVING ONLY THE UNIT. A UNIT DOES NOT INCLUDE (i) STRUCTURAL COMPONENTS OF WALLS, CEILINGS, AND FLOORS, (ii) ANY PORTION OF THE FRAMES OF WINDOWS OR EXTERIOR DOORS NOT EXPOSED WITHIN A UNIT INTERIOR, OR (iii) PORTIONS OF PLUMBING, HEATING, AIR CONDITIONING, OR ELECTRICAL SYSTEMS SERVING MORE THAN ONE UNIT.
3. **COMMON AREA.** THE COMMON AREA CONSISTS OF THE ENTIRE PROPERTY EXCEPT FOR THE UNITS.
4. DIMENSIONS SHOWN AND ELEVATIONS NOTED ON THE CONDOMINIUM PLAN ARE INTENDED TO BE THE UNFINISHED INTERIOR SURFACES OF THE WALLS, FLOORS AND CEILINGS.
5. BUILDING WALLS OF THE UNITS ARE AT NINETY DEGREES AND WALLS ARE 0.8 FEET THICK UNLESS OTHERWISE INDICATED. DIMENSIONS ARE SHOWN IN FEET AND DECIMALS THEREOF.
6. BAY WINDOWS, FIRE ESCAPES AND OTHER ENCROACHMENTS (IF ANY SHOWN HEREON, THAT EXIST, OR THAT MAY BE CONSTRUCTED) ONTO OR OVER TURK STREET ARE PERMITTED THROUGH AND ARE SUBJECT TO THE RESTRICTIONS SET FORTH IN THE BUILDING CODE AND PLANNING CODE OF THE CITY AND COUNTY OF SAN FRANCISCO. THIS MAP DOES NOT CONVEY ANY OWNERSHIP INTEREST IN SUCH ENCROACHMENT AREAS TO THE CONDOMINIUM UNIT OWNER(S).

**GENERAL NOTES CONTINUED ON SHEET 2**

**EXHIBIT "B"**  
**A RESIDENTIAL CONDOMINIUM PLAN FOR**  
**1345 TURK STREET**

SAN FRANCISCO, CALIFORNIA  
ASSESSOR'S BLOCK 0756, LOT 017

**GENERAL NOTES CONTINUED:**

7. THE AREAS ENTITLED "P-1", "P-2", "P-3" AND "P-5" THROUGH "P-24" ARE PARKING AREAS AND "HC-4" IS AN AREA FOR HANDICAP PARKING PURPOSES, AND ARE SUBJECT TO A LICENSE AGREEMENT BETWEEN THE HOMEOWNERS' ASSOCIATION AND INDIVIDUAL OWNERS.
8. THE AREAS ENTITLED "D-101", "D-102", "D-103", "D-104", "D-105", "D-105-A", "D-106", "D-106-A", "D-107", "D-107-A", "D-108", "D-108-A", "D-109", "D-109-A", "D-110", "D-110-A", "D-111", "D-111-A", "D-112", "D-112-A", "D-201", "D-202", "D-203", "D-204", "D-205", "D-206", "D-207", "D-208", "D-209", "D-210", "D-211", "D-212", "D-215", "D-216", "D-217", "D-218" AND "D-220" ARE EXCLUSIVE USE EASEMENT AREAS FOR DECK PURPOSES AND SHALL BE GRANTED AS AN APPURTENANCE TO THE CORRESPONDINGLY NUMBERED UNIT. THE VERTICAL LIMITATIONS SHALL BE THE SAME AS THE ADJOINING UNIT.
9. ELEVATIONS SHOWN HEREON WERE OBTAINED FROM A GROUP OF CITY BENCHMARKS, LOCATED AT THE INTERSECTION OF TURK STREET AND FILLMORE STREET; ELEVATIONS ARE BASED ON CITY OF SAN FRANCISCO DATUM. S.W. CORNER, LETTER "O" IN "OPEN" TOP HPFS HYDRANT. ELEVATION = 102.105

**EXHIBIT "B"**  
**A RESIDENTIAL CONDOMINIUM PLAN FOR**  
**1345 TURK STREET**  
SAN FRANCISCO, CALIFORNIA  
ASSESSOR'S BLOCK 0756, LOT 017

**OWNER'S STATEMENT:**

WE HEREBY STATE THAT WE ARE THE ONLY OWNERS OF AND HOLDERS OF SECURITY INTEREST OR HAVE SOME RECORD TITLE OR INTEREST IN AND TO THE REAL PROPERTY INCLUDED WITH THE SUBDIVISION SHOWN UPON THE ATTACHED CONDOMINIUM PLAN; THAT WE ARE THE ONLY PERSONS WHOSE CONSENT IS NECESSARY TO PASS CLEAR TITLE TO SAID REAL PROPERTY; THAT WE CONSENT TO THE MAKING AND RECORDING OF SAID CONDOMINIUM PLAN AND SUBDIVISION AS SHOWN; THAT SAID CONDOMINIUM PLAN CONSTITUTES AND CONSISTS OF CERTIFIED DIAGRAMMATIC FLOOR PLANS WITHIN THE MEANING OF PARAGRAPH 1351(E) OF THE CIVIL CODE OF THE STATE OF CALIFORNIA AND THAT WE HEREBY CONSENT TO THE MAKING AND RECORDING OF SAID CONDOMINIUM PLAN PURSUANT TO CHAPTER 1, TITLE 6, PART 4, DIVISION SECOND OF THE CIVIL CODE OF THE STATE OF CALIFORNIA.

IN WITNESS WHEREOF WE HAVE CAUSED THESE PRESENTS TO BE EXECUTED THIS

17 DAY OF April, 2012.

OWNER(S): MSPDI TURK, LLC, A CALIFORNIA LIMITED LIABILITY COMPANY,  
BY: MICHAEL SIMMONS PROPERTY DEVELOPMENT, INC., A CALIFORNIA CORPORATION

  
BY: MICHAEL SIMMONS, PRESIDENT

**OWNER'S ACKNOWLEDGEMENT:**

STATE OF CALIFORNIA

COUNTY OF San Francisco

ON 4/17/12, BEFORE ME, Adam G. Keim, Notary Public  
(INSERT NAME AND TITLE OF OFFICER)

PERSONALLY APPEARED Michael Simmons  
WHO PROVED TO ME ON THE BASIS OF SATISFACTORY EVIDENCE TO BE THE PERSON(S) WHOSE NAME(S) IS/ARE  
SUBSCRIBED TO THE WITHIN INSTRUMENT AND ACKNOWLEDGED TO ME THAT HE/SHE/THEY EXECUTED THE SAME  
IN HIS/HER/THEIR AUTHORIZED CAPACITY(IES), AND THAT BY HIS/HER/THEIR SIGNATURE(S) ON THE INSTRUMENT  
THE PERSON(S), OR THE ENTITY UPON BEHALF OF WHICH THE PERSON(S) ACTED, EXECUTED THE INSTRUMENT.

I CERTIFY UNDER PENALTY OF PERJURY UNDER THE LAWS OF THE STATE OF CALIFORNIA THAT THE FOREGOING  
PARAGRAPH IS TRUE AND CORRECT.

WITNESS MY HAND AND OFFICIAL SEAL.

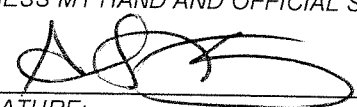
  
SIGNATURE: \_\_\_\_\_

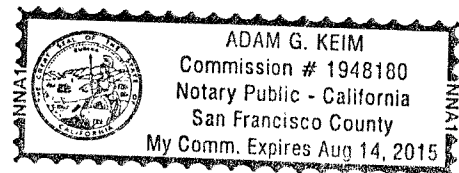

**EXHIBIT "B"**  
**A RESIDENTIAL CONDOMINIUM PLAN FOR**  
**1345 TURK STREET**

SAN FRANCISCO, CALIFORNIA  
ASSESSOR'S BLOCK 0756, LOT 017

City and County of San Francisco, a municipal corporation (as successor agency to the Redevelopment Agency of the City and County of San Francisco), acting by and through the Mayors Office of Housing

~~TRUSTEE~~ / BENEFICIARY:

BY: *Olson Lee*

Director, Mayor's Office of Housing  
CAPACITY:

Olson Lee  
PRINTED NAME:

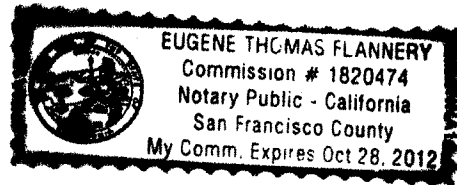

**TRUSTEE / BENEFICIARY'S ACKNOWLEDGEMENT:**

STATE OF CALIFORNIA

COUNTY OF SAN FRANCISCO

ON APRIL 16, 2012, BEFORE ME, EUGENE T. FLANNERY, NP  
(INSERT NAME AND TITLE OF OFFICER)

PERSONALLY APPEARED OLSON LEE  
WHO PROVED TO ME ON THE BASIS OF SATISFACTORY EVIDENCE TO BE THE PERSON(S) WHOSE NAME(S) IS/ARE SUBSCRIBED TO THE WITHIN INSTRUMENT AND ACKNOWLEDGED TO ME THAT HE/SHE/THEY EXECUTED THE SAME IN HIS/HER/THEIR AUTHORIZED CAPACITY(IES), AND THAT BY HIS/HER/THEIR SIGNATURE(S) ON THE INSTRUMENT THE PERSON(S), OR THE ENTITY UPON BEHALF OF WHICH THE PERSON(S) ACTED, EXECUTED THE INSTRUMENT.

I CERTIFY UNDER PENALTY OF PERJURY UNDER THE LAWS OF THE STATE OF CALIFORNIA THAT THE FOREGOING PARAGRAPH IS TRUE AND CORRECT.

WITNESS MY HAND AND OFFICIAL SEAL

*Eugene T. Flannery*  
SIGNATURE:

**EXHIBIT "B"**  
**A RESIDENTIAL CONDOMINIUM PLAN FOR**  
**1345 TURK STREET**

SAN FRANCISCO, CALIFORNIA  
ASSESSOR'S BLOCK 0756, LOT 017

WELLS FARGO BANK, NATIONAL ASSOCIATION  
TRUSTEE / BENEFICIARY: \_\_\_\_\_

Margaret Schrand  
BY: \_\_\_\_\_

SENIOR VICE PRESIDENT  
CAPACITY: \_\_\_\_\_

MARGARET M. SCHRAND  
PRINTED NAME: \_\_\_\_\_

**TRUSTEE / BENEFICIARY'S ACKNOWLEDGEMENT:**

STATE OF CALIFORNIA

COUNTY OF San Francisco )

ON April 12, 2012, BEFORE ME, Lisa Park, Notary Public  
(INSERT NAME AND TITLE OF OFFICER)

PERSONALLY APPEARED Margaret M. Schrand  
WHO PROVED TO ME ON THE BASIS OF SATISFACTORY EVIDENCE TO BE THE PERSON(S) WHOSE NAME(S) IS/ARE  
SUBSCRIBED TO THE WITHIN INSTRUMENT AND ACKNOWLEDGED TO ME THAT HE/SHE/HEY EXECUTED THE SAME  
IN HIS/HER/THEIR AUTHORIZED CAPACITY(IES), AND THAT BY HIS/HER/THEIR SIGNATURE(S) ON THE INSTRUMENT  
THE PERSON(S), OR THE ENTITY UPON BEHALF OF WHICH THE PERSON(S) ACTED, EXECUTED THE INSTRUMENT.

I CERTIFY UNDER PENALTY OF PERJURY UNDER THE LAWS OF THE STATE OF CALIFORNIA THAT THE FOREGOING  
PARAGRAPH IS TRUE AND CORRECT.

WITNESS MY HAND AND OFFICIAL SEAL.

Lisa Park  
SIGNATURE: \_\_\_\_\_

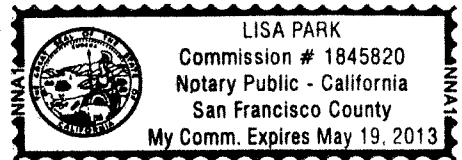

**EXHIBIT "B"**  
**A RESIDENTIAL CONDOMINIUM PLAN FOR**  
**1345 TURK STREET**

SAN FRANCISCO, CALIFORNIA  
 ASSESSOR'S BLOCK 0756, LOT 017

**SCHEDULE OF UNDIVIDED INTEREST IN THE COMMON AREA**  
**1345 TURK STREET CONDOMINIUMS**

THE PERCENTAGE OF OWNERSHIP INTEREST OF EACH OWNER AS A TENANT IN  
 COMMON IS AS FOLLOWS:

<u>UNIT NUMBER</u>	<u>ASSESSOR'S LOT NUMBER</u>	<u>PERCENTAGE</u>	<u>SQ. FT.</u>
101	019	4.0%	1,237
102	020	3.9%	1,205
103	021	3.9%	1,204
104	022	3.9%	1,200
105	023	4.0%	1,207
106	024	3.9%	1,203
107	025	2.1%	626
108	026	2.1%	628
109	027	3.9%	1,201
110	028	3.9%	1,201
111	029	2.1%	629
112	030	2.6%	796

**EXHIBIT "B"**  
**A RESIDENTIAL CONDOMINIUM PLAN FOR**  
**1345 TURK STREET**

SAN FRANCISCO, CALIFORNIA  
 ASSESSOR'S BLOCK 0756, LOT 017

**SCHEDULE OF UNDIVIDED INTEREST IN THE COMMON AREA**  
**1345 TURK STREET CONDOMINIUMS**

**THE PERCENTAGE OF OWNERSHIP INTEREST OF EACH OWNER AS A TENANT IN  
 COMMON IS AS FOLLOWS:**

<u>UNIT NUMBER</u>	<u>ASSESSOR'S LOT NUMBER</u>	<u>PERCENTAGE</u>	<u>SQ. FT.</u>
201	031	3.2%	963
202	032	3.3%	1,005
203	033	3.2%	985
204	034	3.2%	984
205	035	3.2%	967
206	036	3.2%	966
207	037	3.2%	986
208	038	3.2%	980
209	039	3.2%	972
210	040	3.2%	985
211	041	3.2%	968
212	042	3.2%	974
213	043	2.1%	628
214	044	2.1%	634
215	045	3.2%	967
216	046	3.2%	985
217	047	3.2%	966
218	048	3.2%	983
219	049	2.1%	626
220	050	2.1%	653

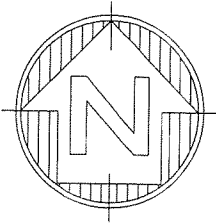

# TURK STREET

68.75' WIDE

FILLMORE STREET 68.75' WIDE

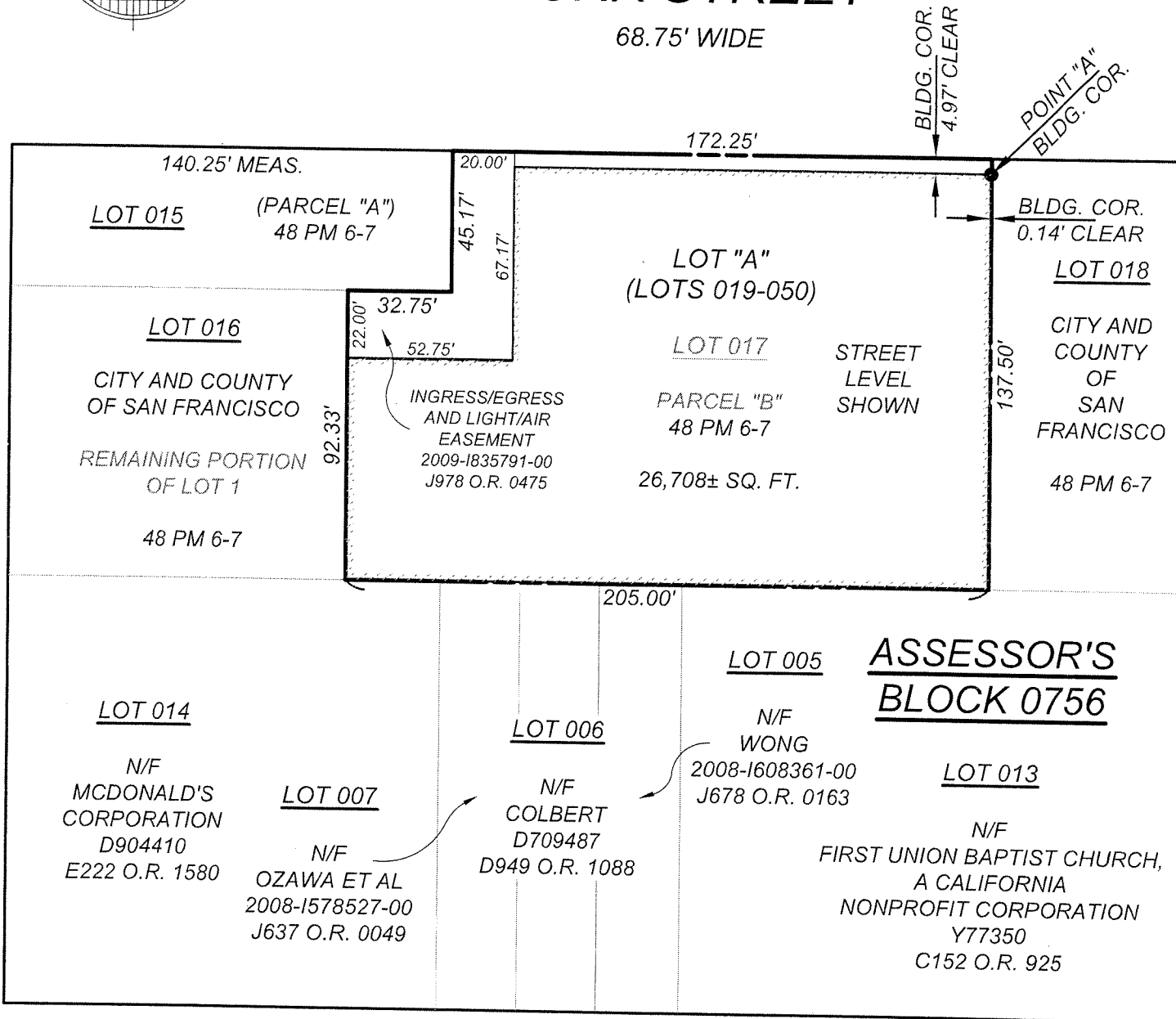

# GOLDEN GATE AVENUE

68.75' WIDE



N/F : NOW OR FORMERLY  
PM : PARCEL MAP

SURVEY: FTS		<b>Frederick T. Seher &amp; Associates, Inc.</b> PROFESSIONAL LAND SURVEYORS 841 LOMBARD STREET, SAN FRANCISCO, CA PHONE (415) 921-7690 FAX (415) 921-7655	1345 TURK STREET ASSESSOR'S BLOCK 0756, LOT 017 CONDOMINIUM PLAN	
DRAWN: OG			SCALE: 1" = 50'	SHEET NO. 8 OF 24
CHECKED: HRF		JOB NO. 1288-08 DATED: APRIL, 2012		

TURK STREET

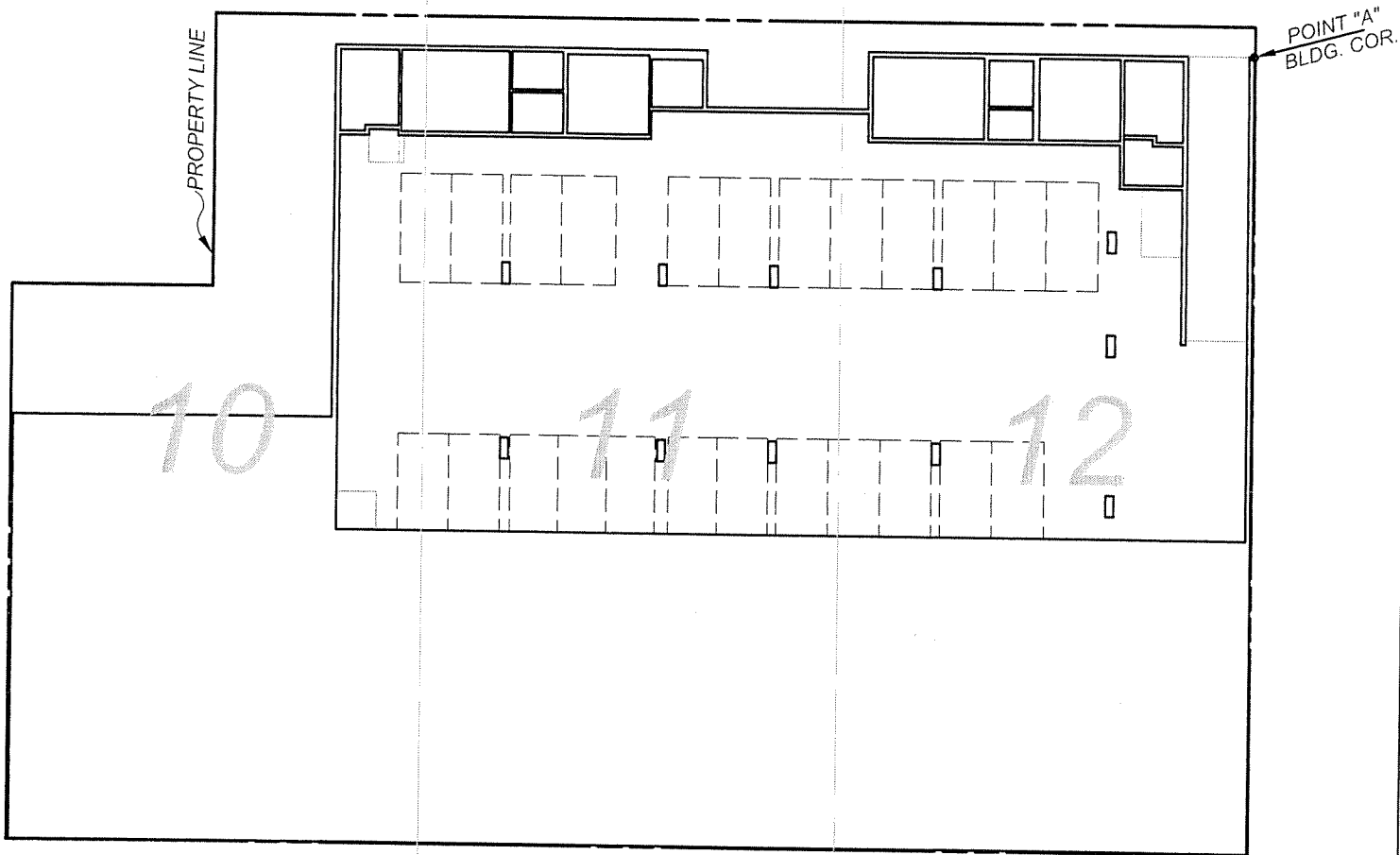

SEE SHEET # FOR  
DETAIL INFORMATION



BASEMENT LEVEL

UPPERMOST ELEVATION (U.E.) = 100.9'  
LOWERMOST ELEVATION (L.E.) = 91.2'

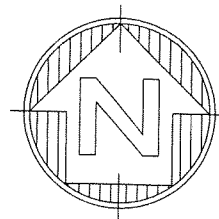

SURVEY:  
FTS  
DRAWN:  
OG  
CHECKED:  
HRF

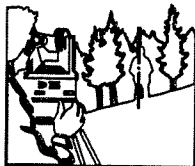

*Frederick T. Seher & Associates, Inc.*

PROFESSIONAL LAND SURVEYORS  
841 LOMBARD STREET, SAN FRANCISCO, CA  
PHONE (415) 921-7690 FAX (415) 921-7655

1345 TURK STREET  
ASSESSOR'S BLOCK 0756, LOT 017  
CONDOMINIUM PLAN

JOB NO. 1288-08 DATED: APRIL, 2012

SCALE: 1" = 30'

SHEET NO. 9 OF 24

# TURK STREET

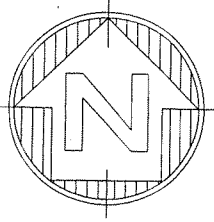

PROPERTY LINE

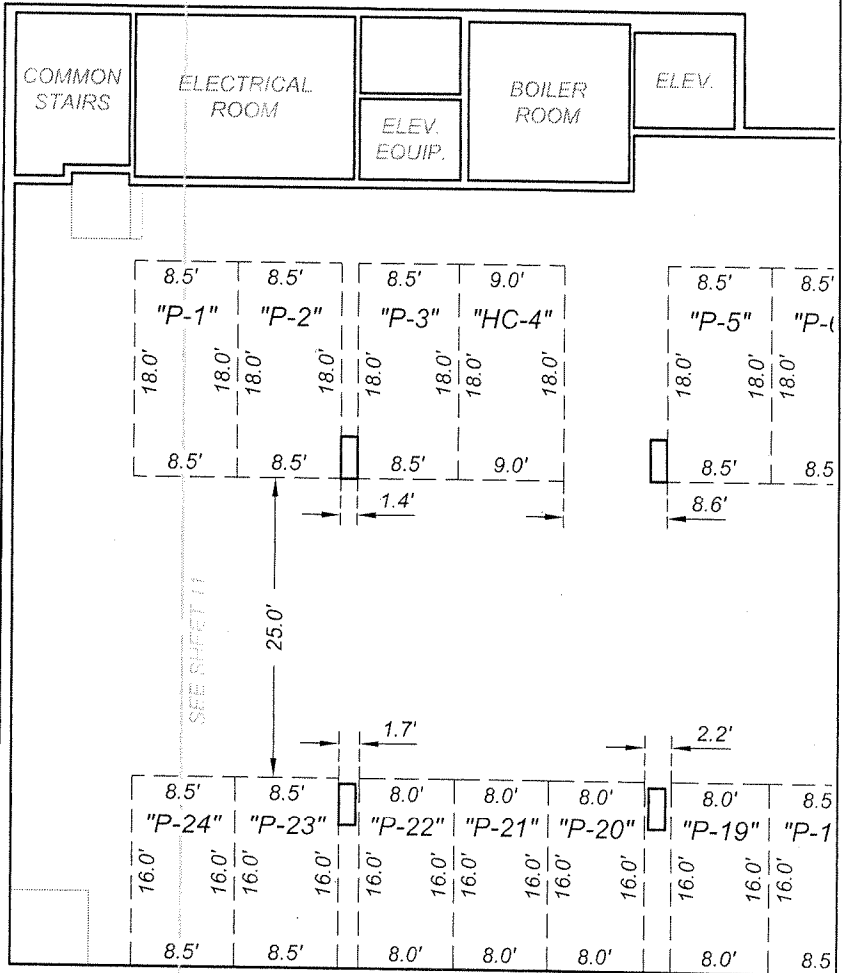

## BASEMENT LEVEL

UPPERMOST ELEVATION (U.E.) = 100.9'  
 LOWERMOST ELEVATION (L.E.) = 91.2'

SURVEY:  
 FTS  
 DRAWN:  
 OG  
 CHECKED:  
 HRF

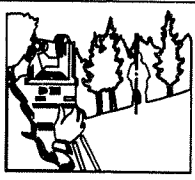

**Frederick T. Seher & Associates, Inc.**  
 PROFESSIONAL LAND SURVEYORS  
 841 LOMBARD STREET, SAN FRANCISCO, CA  
 PHONE (415) 921-7690 FAX (415) 921-7655

JOB NO. 1288-08      DATED: APRIL, 2012

1345 TURK STREET  
 ASSESSOR'S BLOCK 0756, LOT 017  
 CONDOMINIUM PLAN

SCALE: 1" = 16'      SHEET NO. 10 OF 24

# TURK STREET

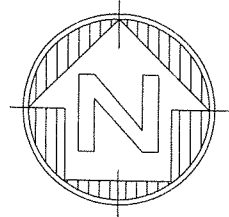
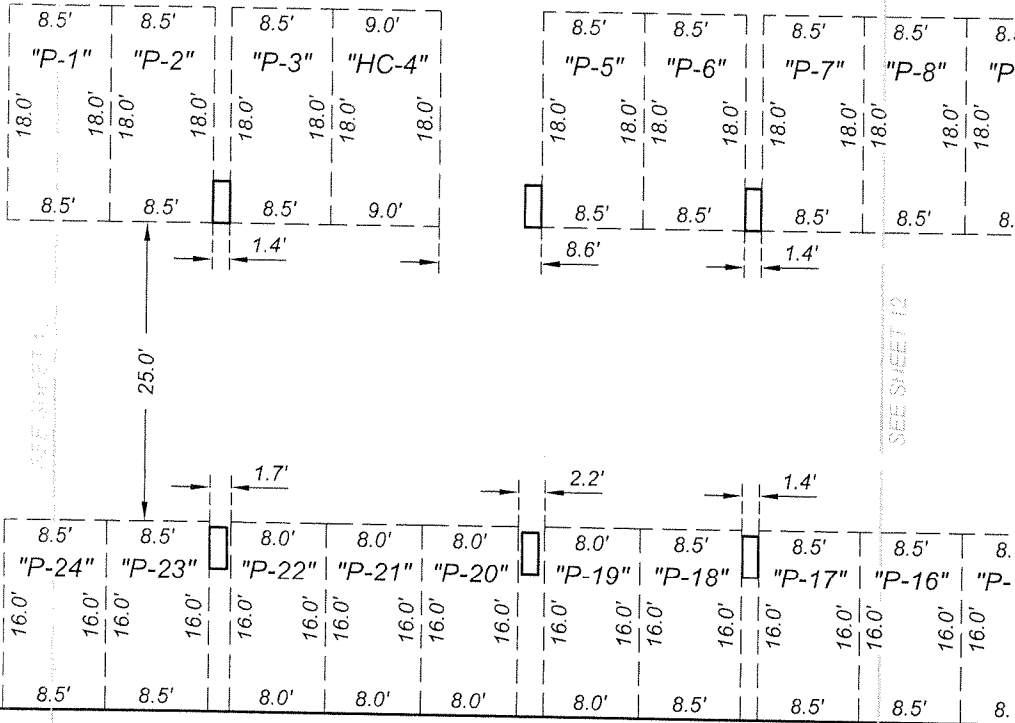
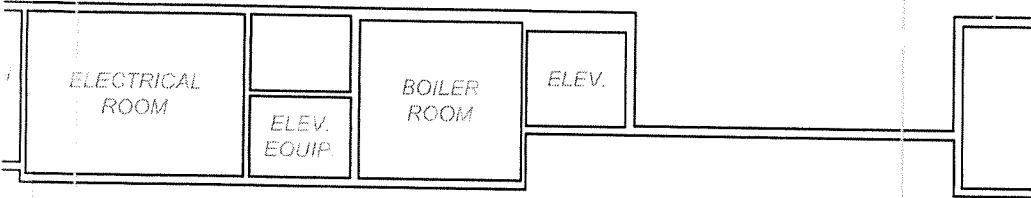

## BASEMENT LEVEL

UPPERMOST ELEVATION (U.E.) = 100.9'  
 LOWERMOST ELEVATION (L.E.) = 91.2'

SURVEY: FTS		<b>Frederick T. Seher &amp; Associates, Inc.</b> PROFESSIONAL LAND SURVEYORS 841 LOMBARD STREET, SAN FRANCISCO, CA PHONE (415) 921-7690 FAX (415) 921-7655	<b>1345 TURK STREET</b> <b>ASSESSOR'S BLOCK 0756, LOT 017</b> <b>CONDOMINIUM PLAN</b>	
DRAWN: OG		JOB NO. 1288-08      DATED: APRIL, 2012	SCALE: 1" = 16'	SHEET NO. 11 OF 24
CHECKED: HRF				

# TURK STREET

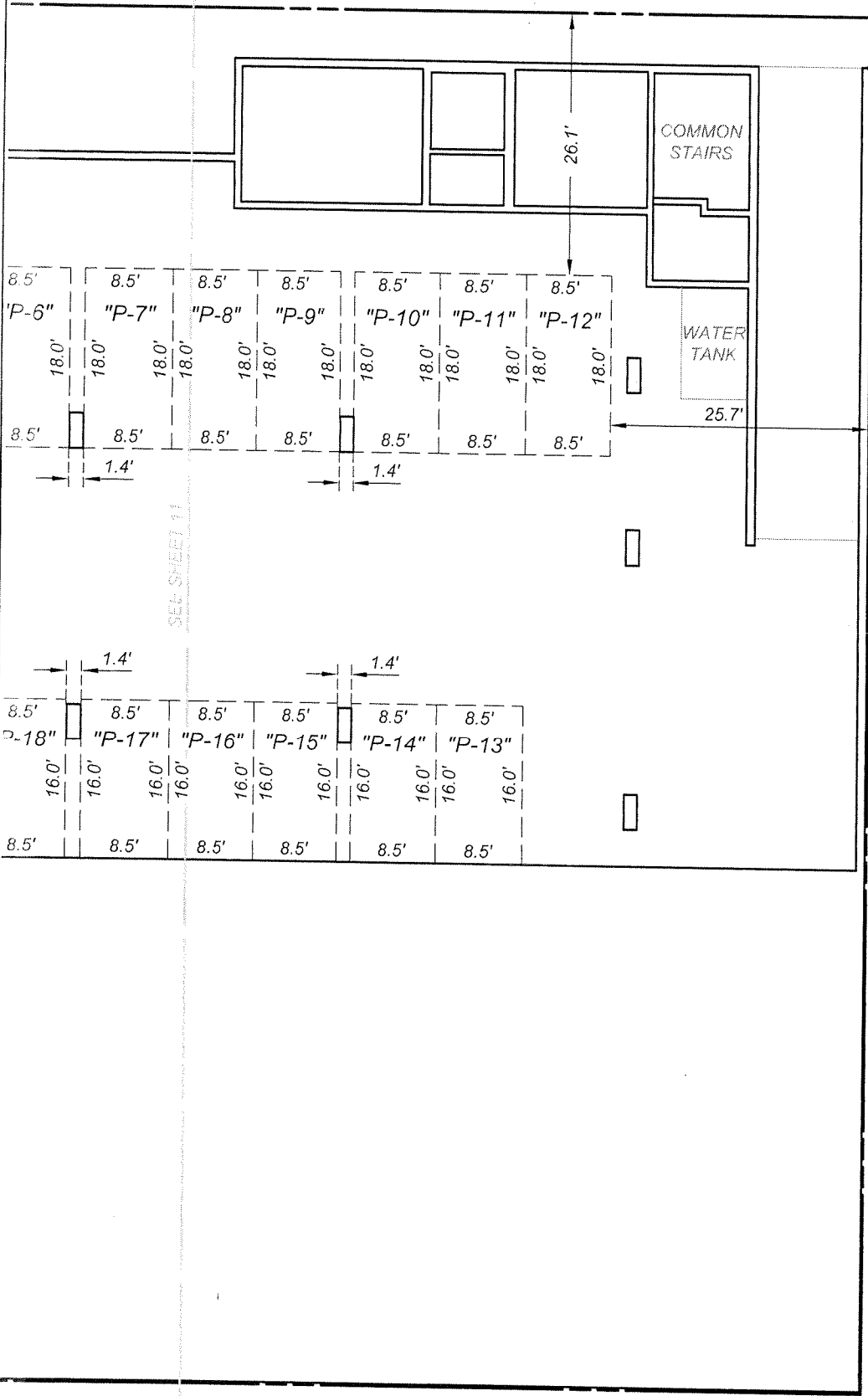

POINT "A"  
BLDG. COR.

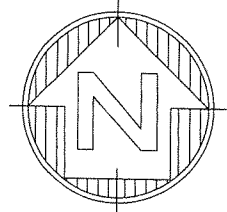

## BASEMENT LEVEL

UPPERMOST ELEVATION (U.E.) = 100.9'  
LOWERMOST ELEVATION (L.E.) = 91.2'

SURVEY:  
FTS  
DRAWN:  
OG  
CHECKED:  
HRF

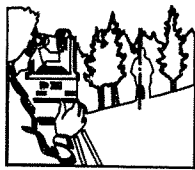

*Frederick T. Seher & Associates, Inc.*  
PROFESSIONAL LAND SURVEYORS  
841 LOMBARD STREET, SAN FRANCISCO, CA  
PHONE (415) 921-7690 FAX (415) 921-7655

1345 TURK STREET  
ASSESSOR'S BLOCK 0756, LOT 017  
CONDOMINIUM PLAN

JOB NO. 1288-08 DATED: APRIL, 2012

SCALE: 1" = 16'

SHEET NO. 12 OF 24

# TURK STREET

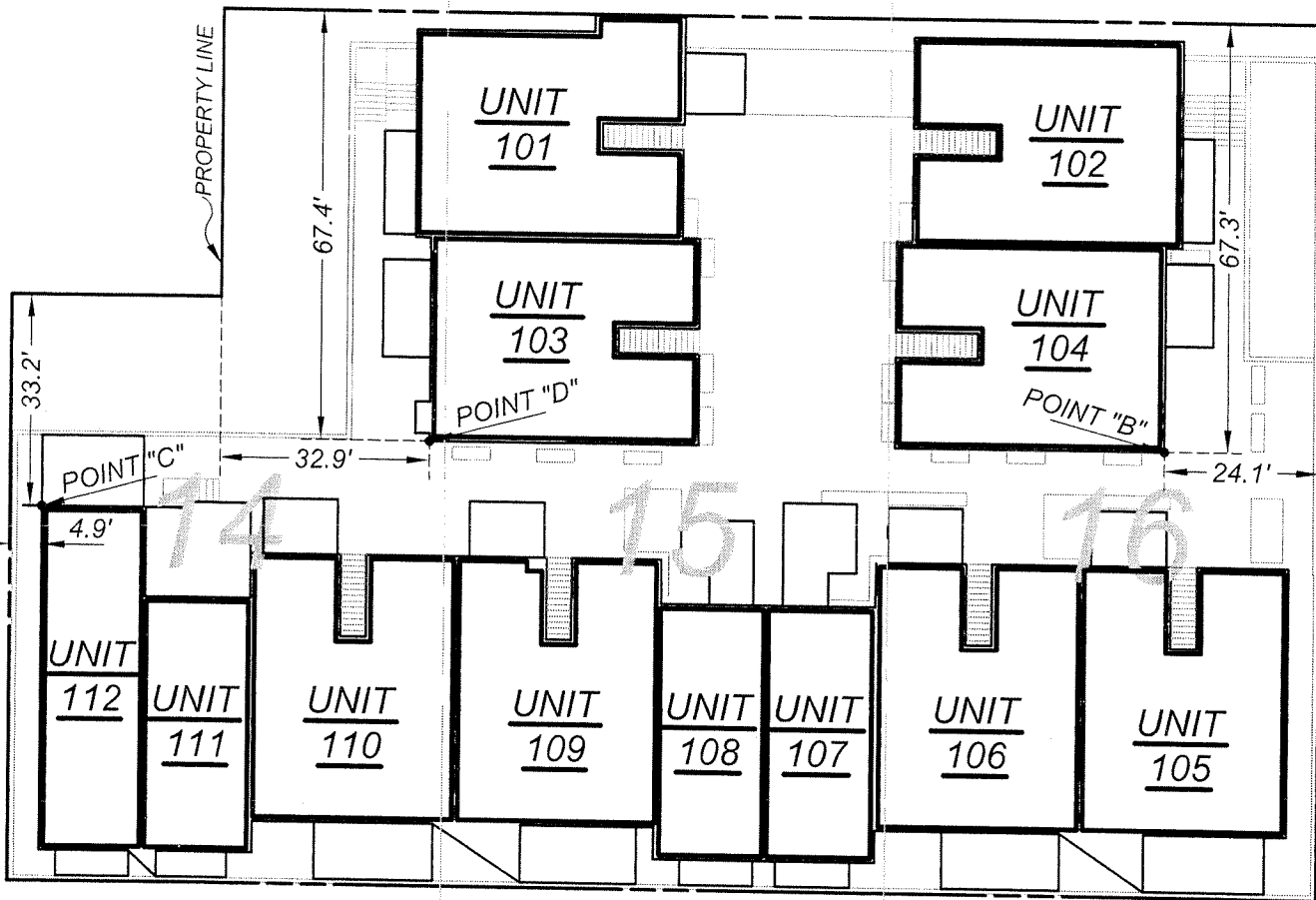

SEE SHEET # FOR  
DETAIL INFORMATION

## STREET LEVEL

UPPERMOST ELEVATION (U.E.) = 111.0'  
LOWERMOST ELEVATION (L.E.) = 102.0'  
(EXCEPT WHERE NOTED)

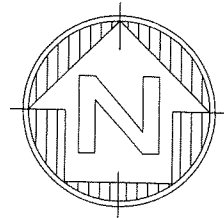

SURVEY: FTS  
DRAWN: OG  
CHECKED: HRF

**Frederick T. Seher & Associates, Inc.**  
PROFESSIONAL LAND SURVEYORS  
841 LOMBARD STREET, SAN FRANCISCO, CA  
PHONE (415) 921-7690 FAX (415) 921-7655

**1345 TURK STREET**  
**ASSESSOR'S BLOCK 0756, LOT 017**  
**CONDOMINIUM PLAN**

JOB NO. 1288-08      DATED: APRIL, 2012      SCALE: 1" = 30'      SHEET NO. 13 OF 24

# TURK STREET

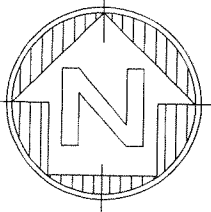

## STREET LEVEL

UPPERMOST ELEVATION (U.E.) = 111.0'  
 LOWERMOST ELEVATION (L.E.) = 102.0'  
 (EXCEPT WHERE NOTED)

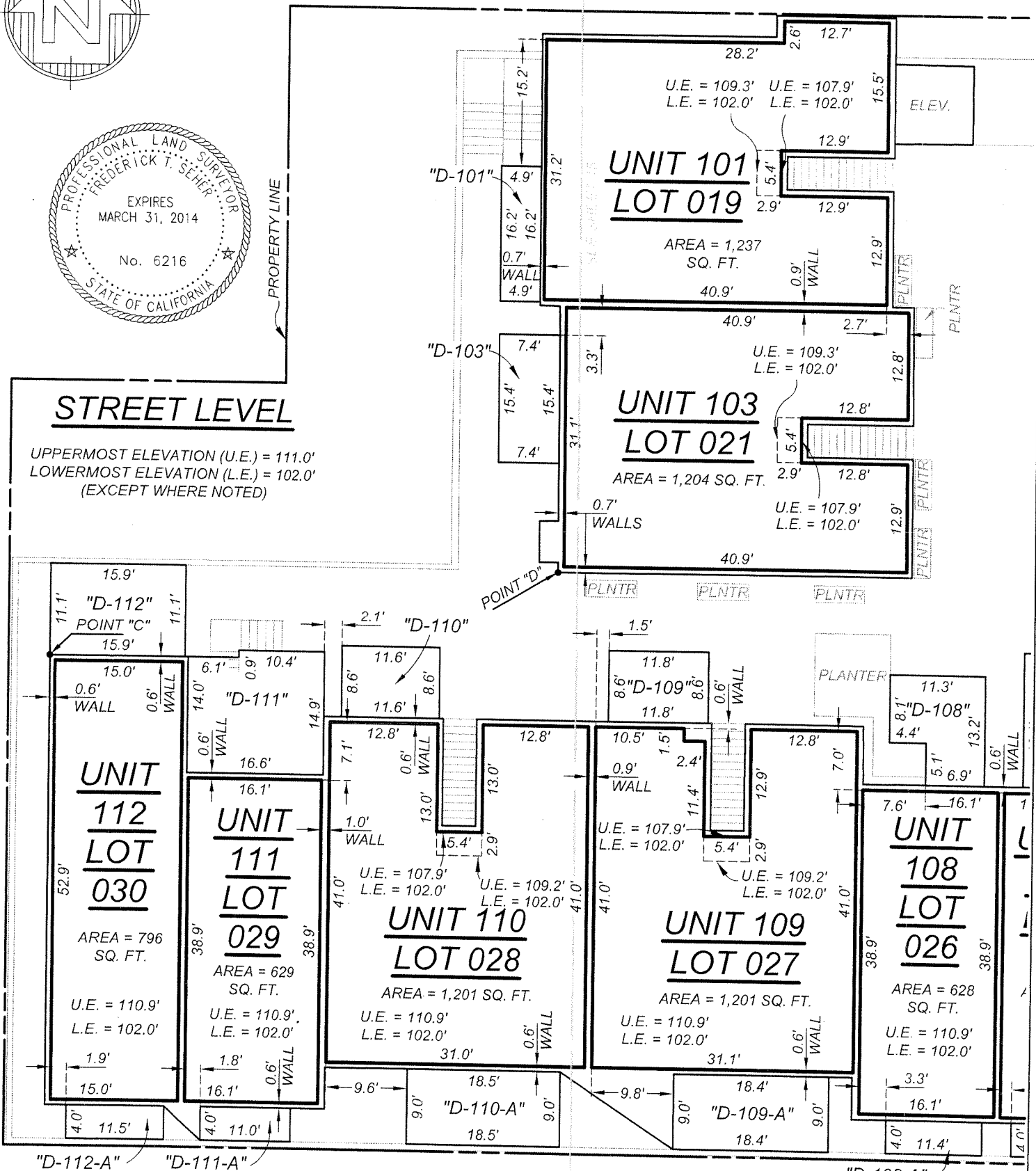

SURVEY: FTS  
 DRAWN: OG  
 CHECKED: HRF

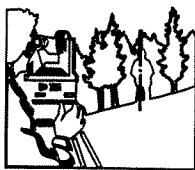

**Frederick T. Seher & Associates, Inc.**  
 PROFESSIONAL LAND SURVEYORS  
 841 LOMBARD STREET, SAN FRANCISCO, CA  
 PHONE (415) 921-7690 FAX (415) 921-7655

1345 TURK STREET  
 ASSESSOR'S BLOCK 0756, LOT 017  
 CONDOMINIUM PLAN

JOB NO. 1288-08 DATED: APRIL, 2012

SCALE: 1" = 16'

SHEET NO. 14 OF 24

# TURK STREET

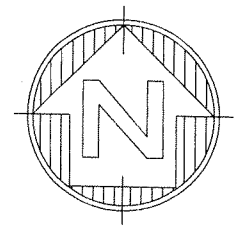
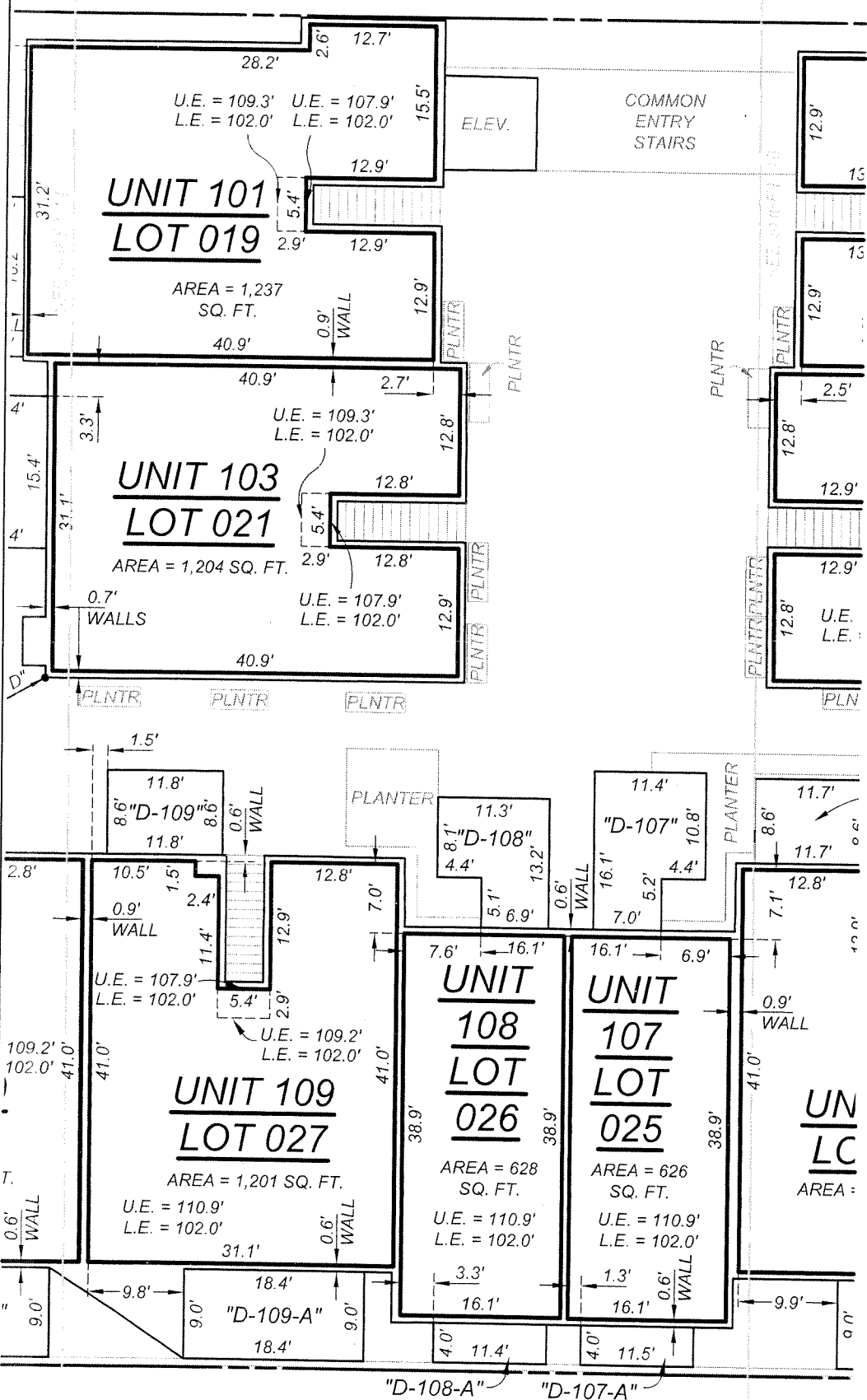

## STREET LEVEL

UPPERMOST ELEVATION (U.E.) = 111.0'  
 LOWERMOST ELEVATION (L.E.) = 102.0'  
 (EXCEPT WHERE NOTED)

SURVEY: FTS  
 DRAWN: OG  
 CHECKED: HRF

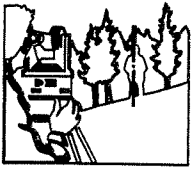

**Frederick T. Seher & Associates, Inc.**  
 PROFESSIONAL LAND SURVEYORS  
 841 LOMBARD STREET, SAN FRANCISCO, CA  
 PHONE (415) 921-7690 FAX (415) 921-7655

1345 TURK STREET  
 ASSESSOR'S BLOCK 0756, LOT 017  
 CONDOMINIUM PLAN

JOB NO. 1288-08 DATED: APRIL, 2012

SCALE: 1" = 16'

SHEET NO. 15 OF 24

# TURK STREET

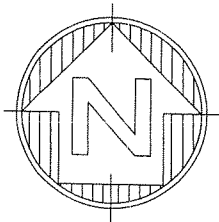
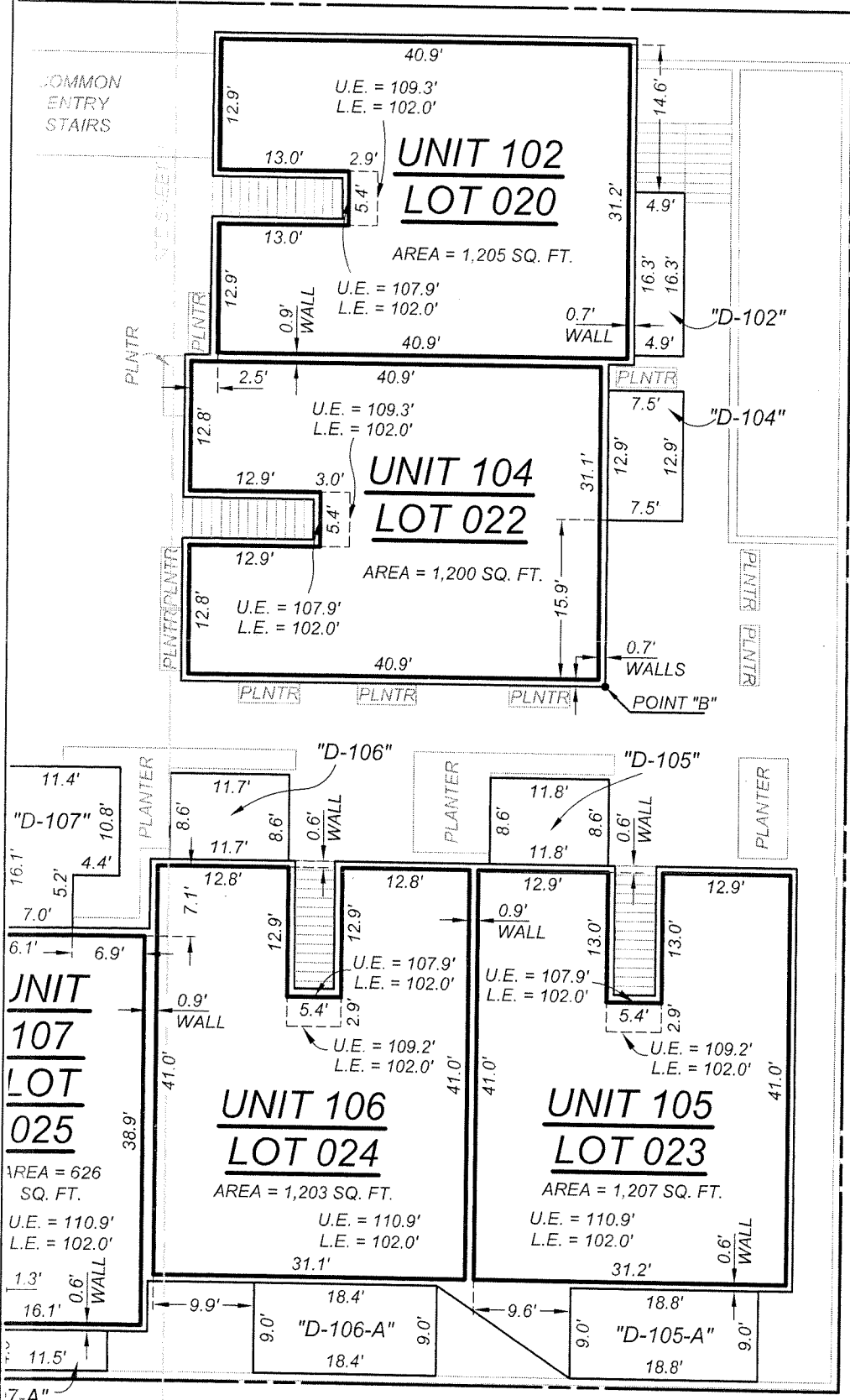

## STREET LEVEL

UPPERMOST ELEVATION (U.E.) = 111.0'  
 LOWERMOST ELEVATION (L.E.) = 102.0'  
 (EXCEPT WHERE NOTED)

SURVEY: FTS  
 DRAWN: OG  
 CHECKED: HRF

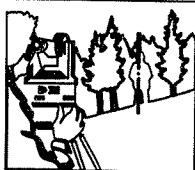

**Frederick T. Seher & Associates, Inc.**  
 PROFESSIONAL LAND SURVEYORS  
 841 LOMBARD STREET, SAN FRANCISCO, CA  
 PHONE (415) 921-7690 FAX (415) 921-7655

**1345 TURK STREET**  
**ASSESSOR'S BLOCK 0756, LOT 017**  
**CONDOMINIUM PLAN**

# TURK STREET

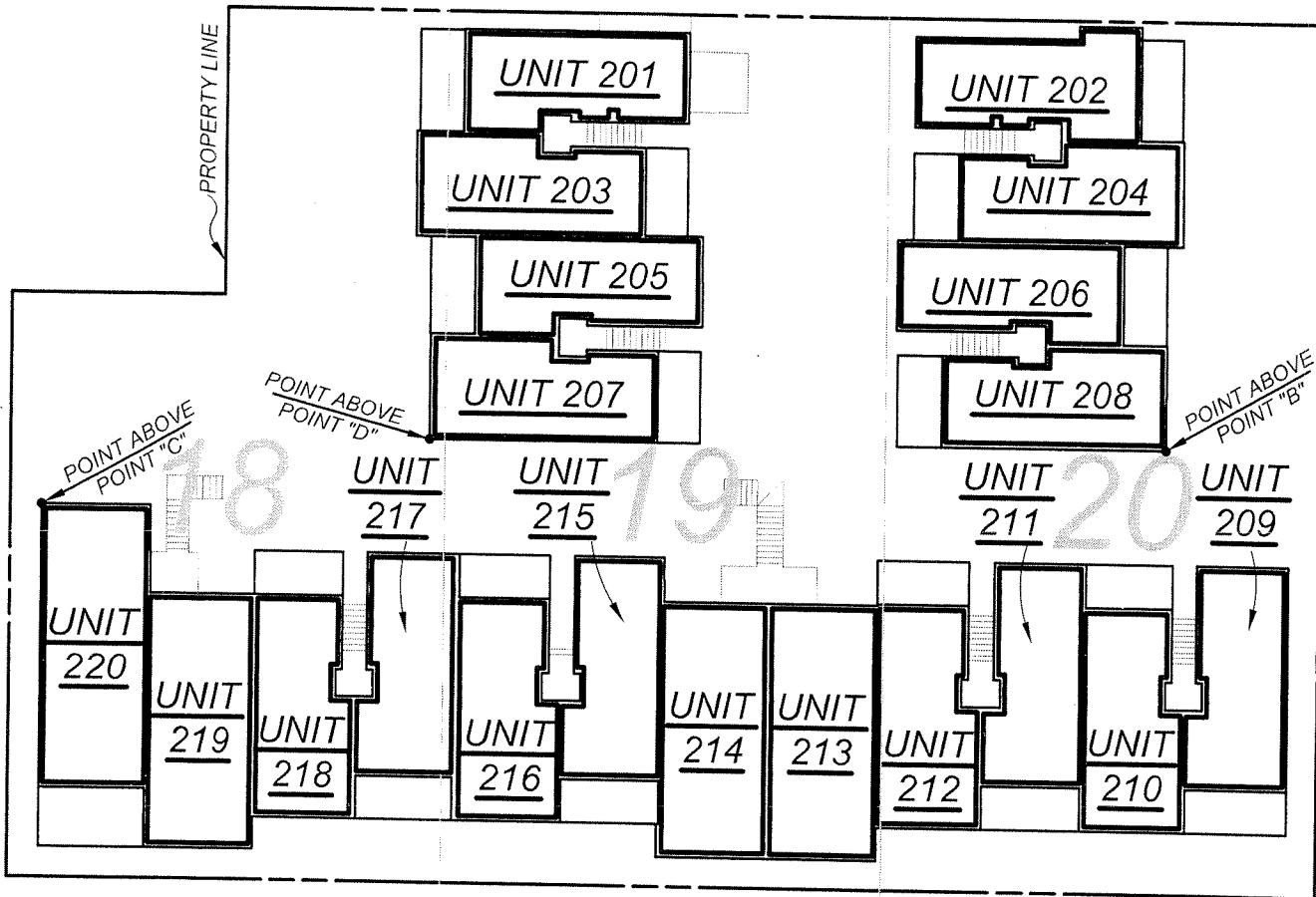

SEE SHEET # FOR  
DETAIL INFORMATION



## 2ND FLOOR

UPPERMOST ELEVATION (U.E.) = 121.1'  
LOWERMOST ELEVATION (L.E.) = 112.0'  
(EXCEPT WHERE NOTED)

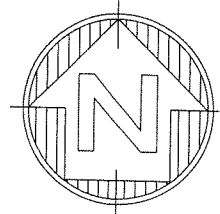

SURVEY:  
FTS  
DRAWN:  
OG  
CHECKED:  
HRF

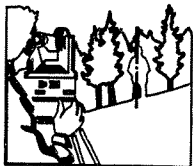

**Frederick T. Seher & Associates, Inc.**

PROFESSIONAL LAND SURVEYORS  
841 LOMBARD STREET, SAN FRANCISCO, CA  
PHONE (415) 921-7690 FAX (415) 921-7655

1345 TURK STREET  
ASSESSOR'S BLOCK 0756, LOT 017  
CONDOMINIUM PLAN

JOB NO. 1288-08      DATED: APRIL, 2012

SCALE: 1" = 30'

SHEET NO. 17 OF 24

# TURK STREET

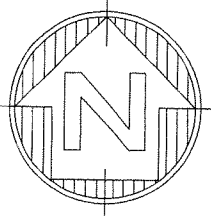

PROPERTY LINE

## 2ND FLOOR

UPPERMOST ELEVATION (U.E.) = 121.1'  
 LOWERMOST ELEVATION (L.E.) = 112.0'  
 (EXCEPT WHERE NOTED)

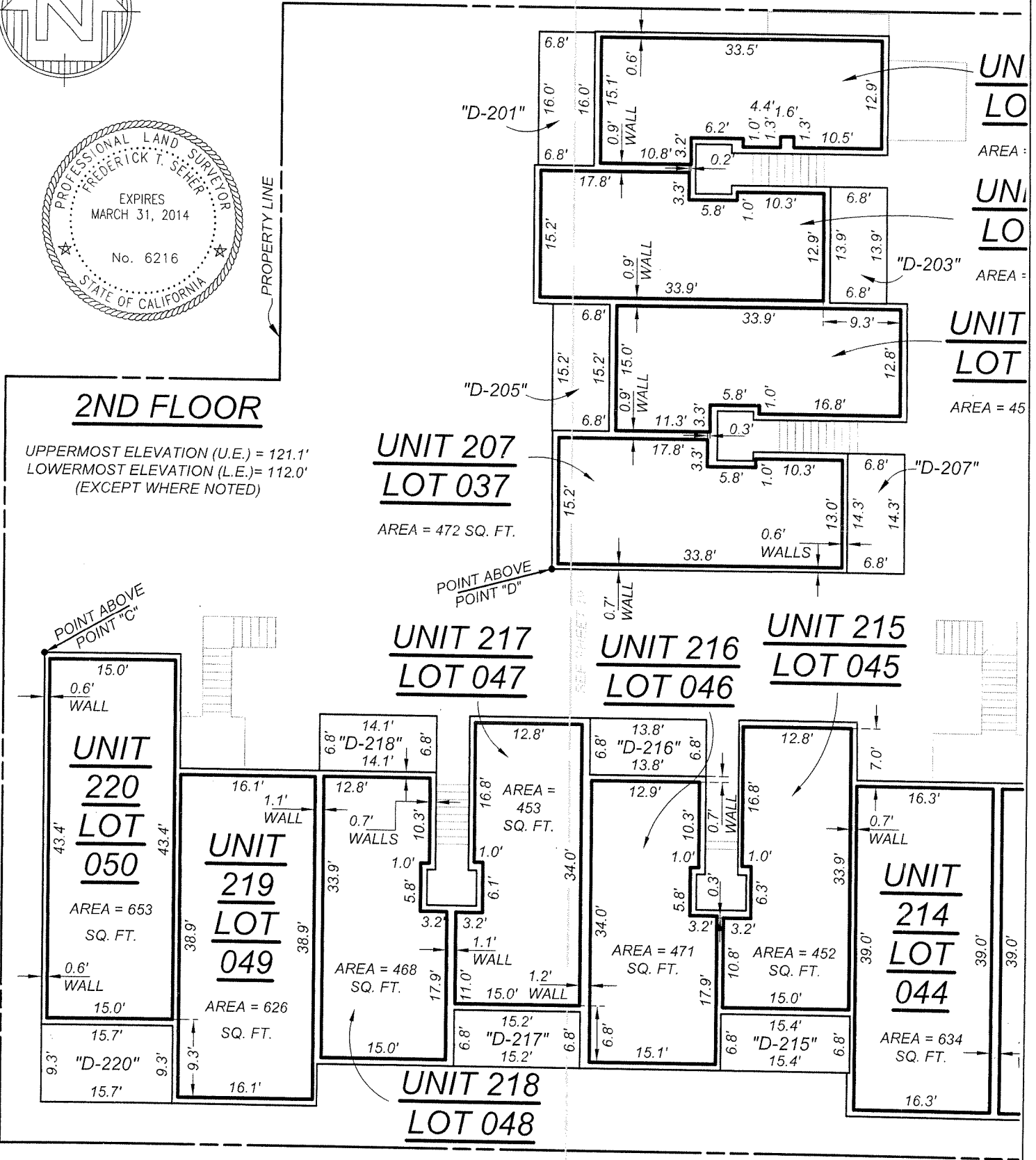

UN  
LO

AREA :

UNI  
LO

AREA :

UNIT  
LOT

AREA = 45

**UNIT 207**  
**LOT 037**

AREA = 472 SQ. FT.

**UNIT 217**  
**LOT 047**

**UNIT 216**  
**LOT 046**

**UNIT 215**  
**LOT 045**

**UNIT 220**  
**LOT 050**

AREA = 653  
SQ. FT.

**UNIT 219**  
**LOT 049**

AREA = 626  
SQ. FT.

**UNIT 218**  
**LOT 048**

AREA = 468  
SQ. FT.

AREA = 453  
SQ. FT.

AREA = 471  
SQ. FT.

AREA = 452  
SQ. FT.

**UNIT 214**  
**LOT 044**

AREA = 634  
SQ. FT.

SURVEY:	
FTS	
DRAWN:	
OG	
CHECKED:	
HRF	

**Frederick T. Seher & Associates, Inc.**  
 PROFESSIONAL LAND SURVEYORS  
 841 LOMBARD STREET, SAN FRANCISCO, CA  
 PHONE (415) 921-7690 FAX (415) 921-7655

1345 TURK STREET  
 ASSESSOR'S BLOCK 0756, LOT 017  
 CONDOMINIUM PLAN

# TURK STREET

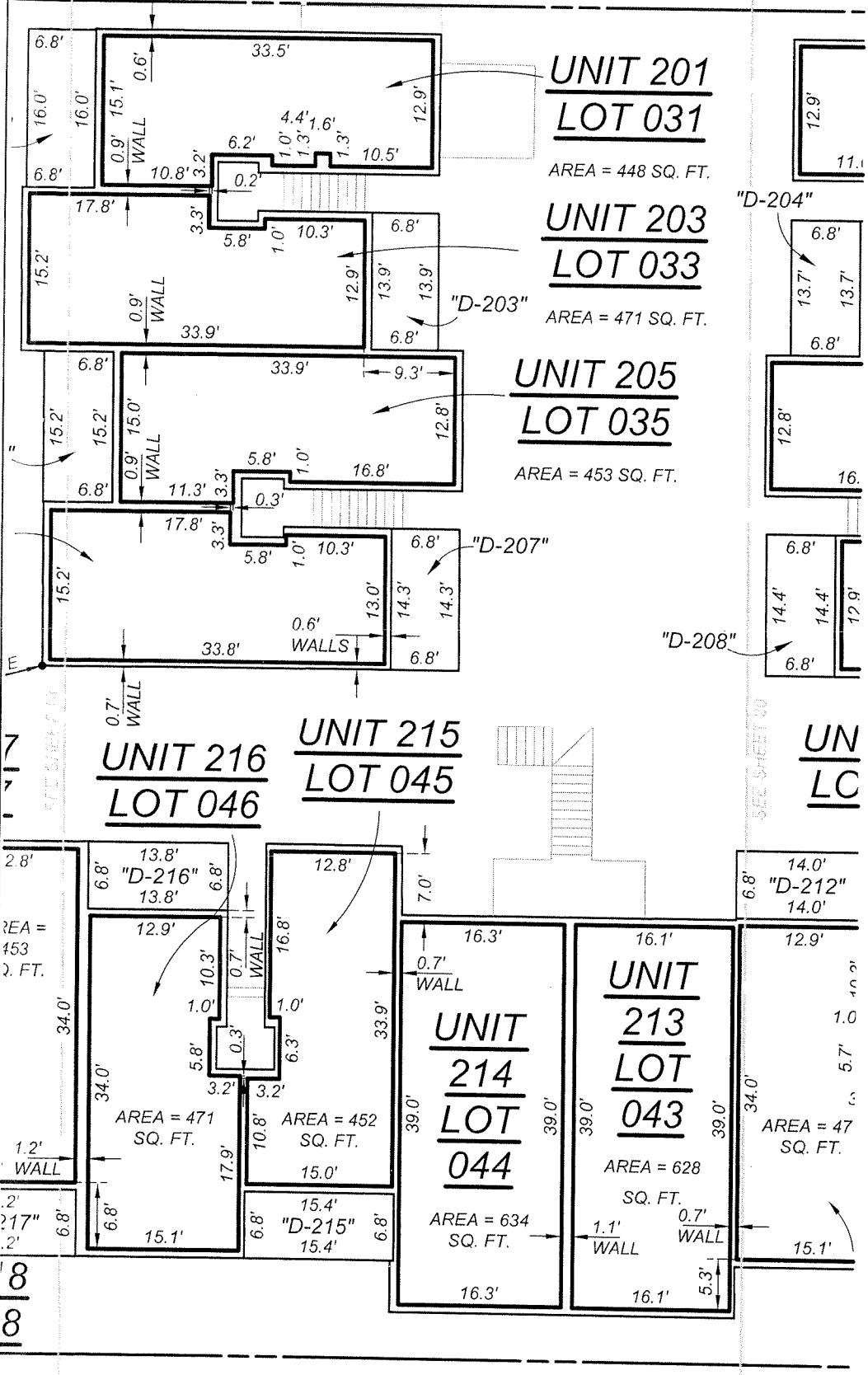

**UNIT 201**  
**LOT 031**

AREA = 448 SQ. FT.

**UNIT 203**  
**LOT 033**

AREA = 471 SQ. FT.

**UNIT 205**  
**LOT 035**

AREA = 453 SQ. FT.

**UNIT 215**  
**LOT 045**

**UNIT 216**  
**LOT 046**

**UN**  
**LC**

**UNIT 214**  
**LOT 044**

**UNIT 213**  
**LOT 043**

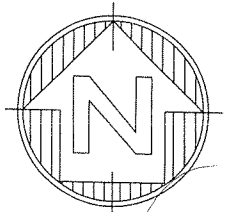

## 2ND FLOOR

UPPERMOST ELEVATION (U.E.) = 121.1'  
LOWERMOST ELEVATION (L.E.) = 112.0'  
(EXCEPT WHERE NOTED)

SURVEY: FTS  
DRAWN: OG  
CHECKED: HRF

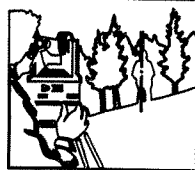

**Frederick T. Seher & Associates, Inc.**  
PROFESSIONAL LAND SURVEYORS  
841 LOMBARD STREET, SAN FRANCISCO, CA  
PHONE (415) 921-7690 FAX (415) 921-7655

1345 TURK STREET  
ASSESSOR'S BLOCK 0756, LOT 017  
CONDOMINIUM PLAN

JOB NO. 1288-08 DATED: APRIL, 2012

SCALE: 1" = 16'

SHEET NO. 19 OF 24

# TURK STREET

**IT 201**  
**T 031**

= 448 SQ. FT.

**IT 203**  
**T 033**

= 471 SQ. FT.

**205**  
**035**

3 SQ. FT.

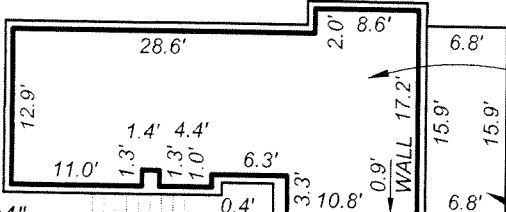

**UNIT 202**  
**LOT 032**

AREA = 472 SQ. FT.

"D-202"

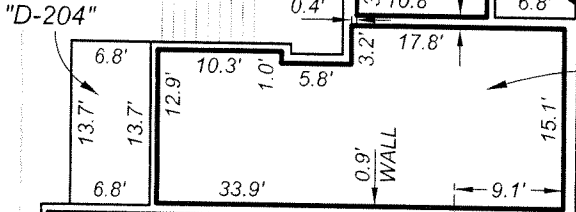

**UNIT 204**  
**LOT 034**

AREA = 471 SQ. FT.

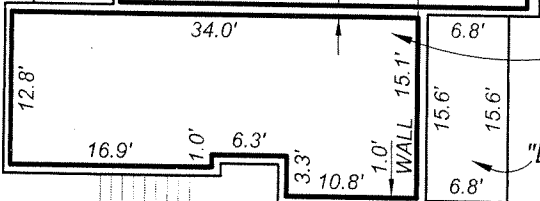

**UNIT 206**  
**LOT 036**

AREA = 452 SQ. FT.

"D-206"

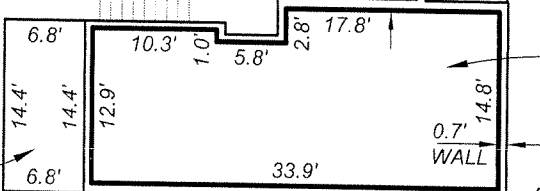

**UNIT 208**  
**LOT 038**

AREA = 465 SQ. FT.

"D-208"

POINT ABOVE  
POINT "B"

**UNIT 211**  
**LOT 041**

**UNIT 210**  
**LOT 040**

**UNIT 209**  
**LOT 039**

**UNIT 213**  
**LOT 043**

AREA = 628  
SQ. FT.

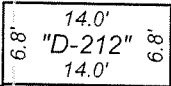
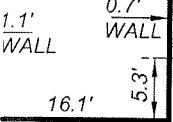

AREA = 471  
SQ. FT.

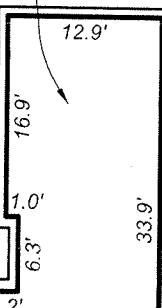

AREA = 454  
SQ. FT.

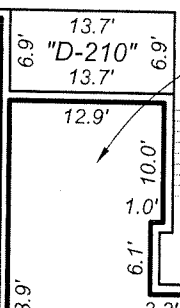

AREA = 472  
SQ. FT.

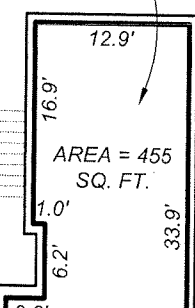

AREA = 455  
SQ. FT.

**UNIT 212**  
**LOT 042**

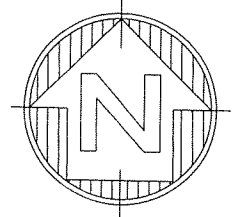

## 2ND FLOOR

UPPERMOST ELEVATION (U.E.) = 121.1'  
LOWERMOST ELEVATION (L.E.) = 112.0'  
(EXCEPT WHERE NOTED)

SURVEY:  
FTS  
DRAWN:  
OG  
CHECKED:  
HRF



**Frederick T. Seher & Associates, Inc.**

PROFESSIONAL LAND SURVEYORS  
841 LOMBARD STREET, SAN FRANCISCO, CA  
PHONE (415) 921-7690 FAX (415) 921-7655

1345 TURK STREET  
ASSESSOR'S BLOCK 0756, LOT 017  
CONDOMINIUM PLAN

JOB NO. 1288-08

DATED: APRIL, 2012

SCALE: 1" = 16'

SHEET NO. 20 OF 24

TURK STREET

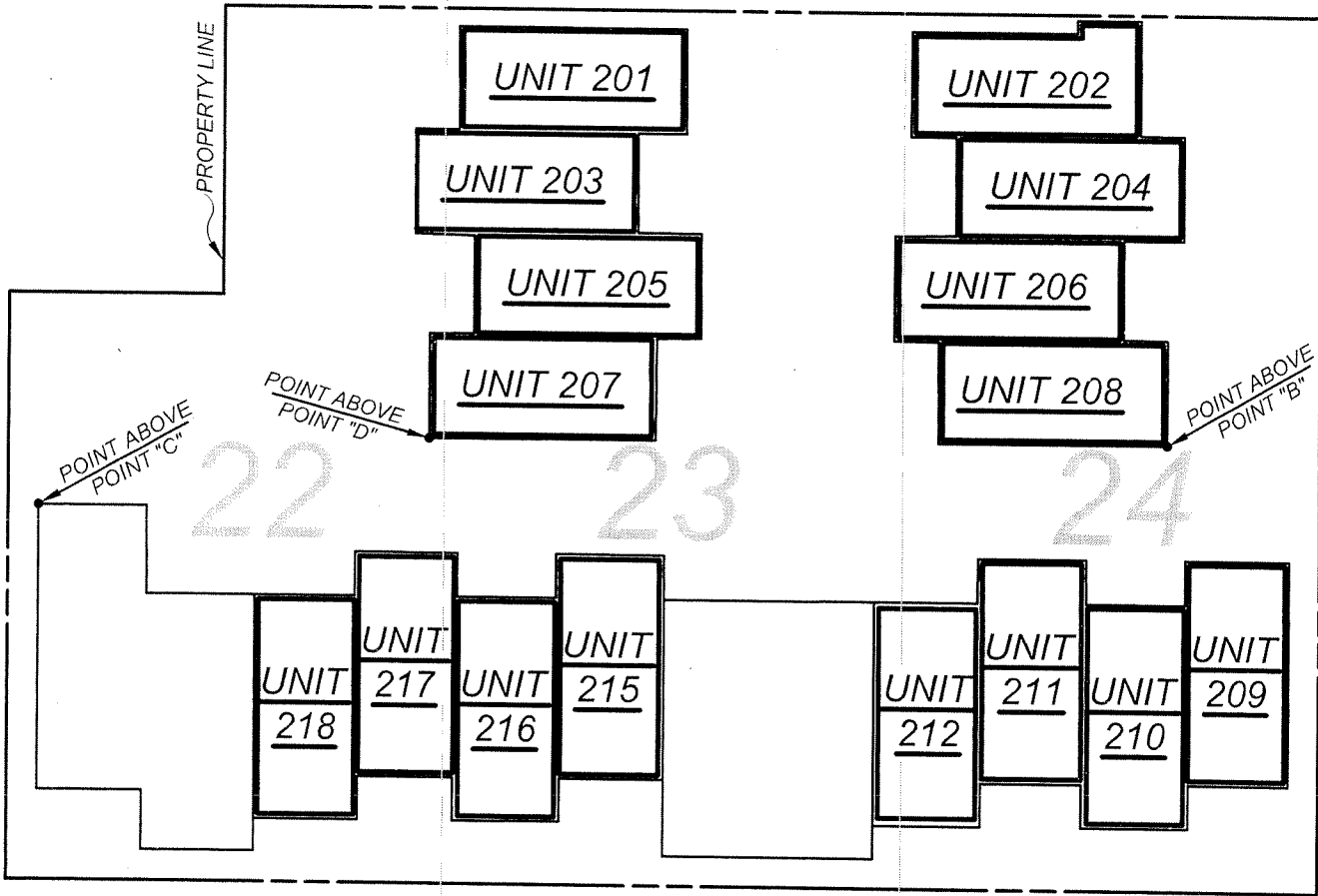

SEE SHEET # FOR  
DETAIL INFORMATION



3RD FLOOR

UPPERMOST ELEVATION = 130.0'  
LOWERMOST ELEVATION = 122.1'

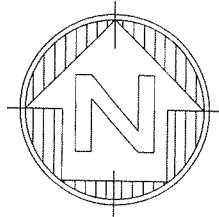

SURVEY: FTS		Frederick T. Seher & Associates, Inc.	1345 TURK STREET	
DRAWN: O.G.		PROFESSIONAL LAND SURVEYORS 841 LOMBARD STREET, SAN FRANCISCO, CA PHONE (415) 921-7690 FAX (415) 921-7655	ASSESSOR'S BLOCK 0756, LOT 017	
CHECKED:			CONDOMINIUM PLAN	
		JOB NO. 1288-08      DATED: APRIL, 2012	SCALE: 1" = 30'	SHEET NO. 21 OF 24

# TURK STREET

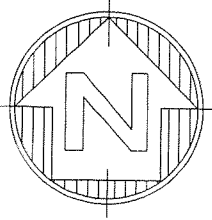

PROPERTY LINE

## 3RD FLOOR

UPPERMOST ELEVATION = 130.0'  
 LOWERMOST ELEVATION = 122.1'

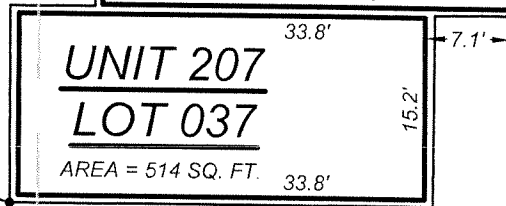
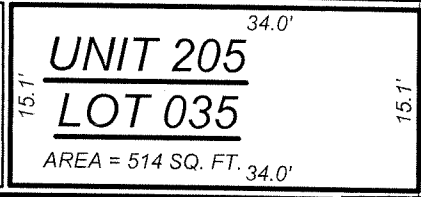
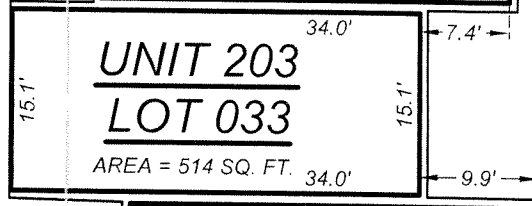
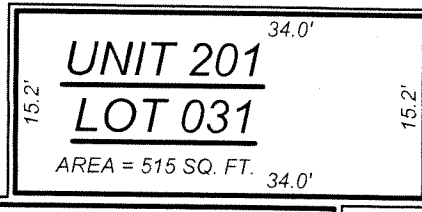

POINT ABOVE  
POINT "D"

POINT ABOVE  
POINT "C"

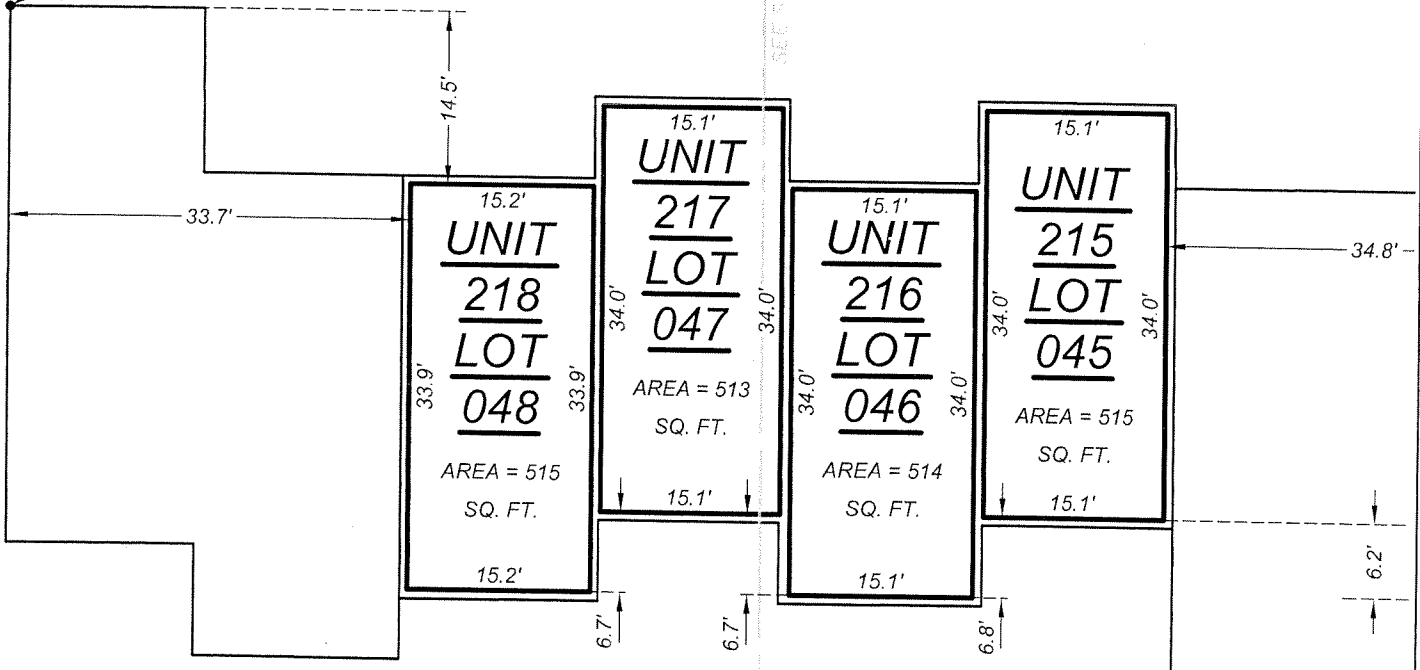

SURVEY: FTS  
 DRAWN: OG  
 CHECKED: HRF

**Frederick T. Seher & Associates, Inc.**  
 PROFESSIONAL LAND SURVEYORS  
 841 LOMBARD STREET, SAN FRANCISCO, CA  
 PHONE (415) 921-7690 FAX (415) 921-7655

1345 TURK STREET  
 ASSESSOR'S BLOCK 0756, LOT 017  
 CONDOMINIUM PLAN

# TURK STREET

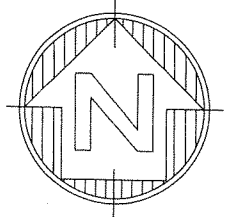
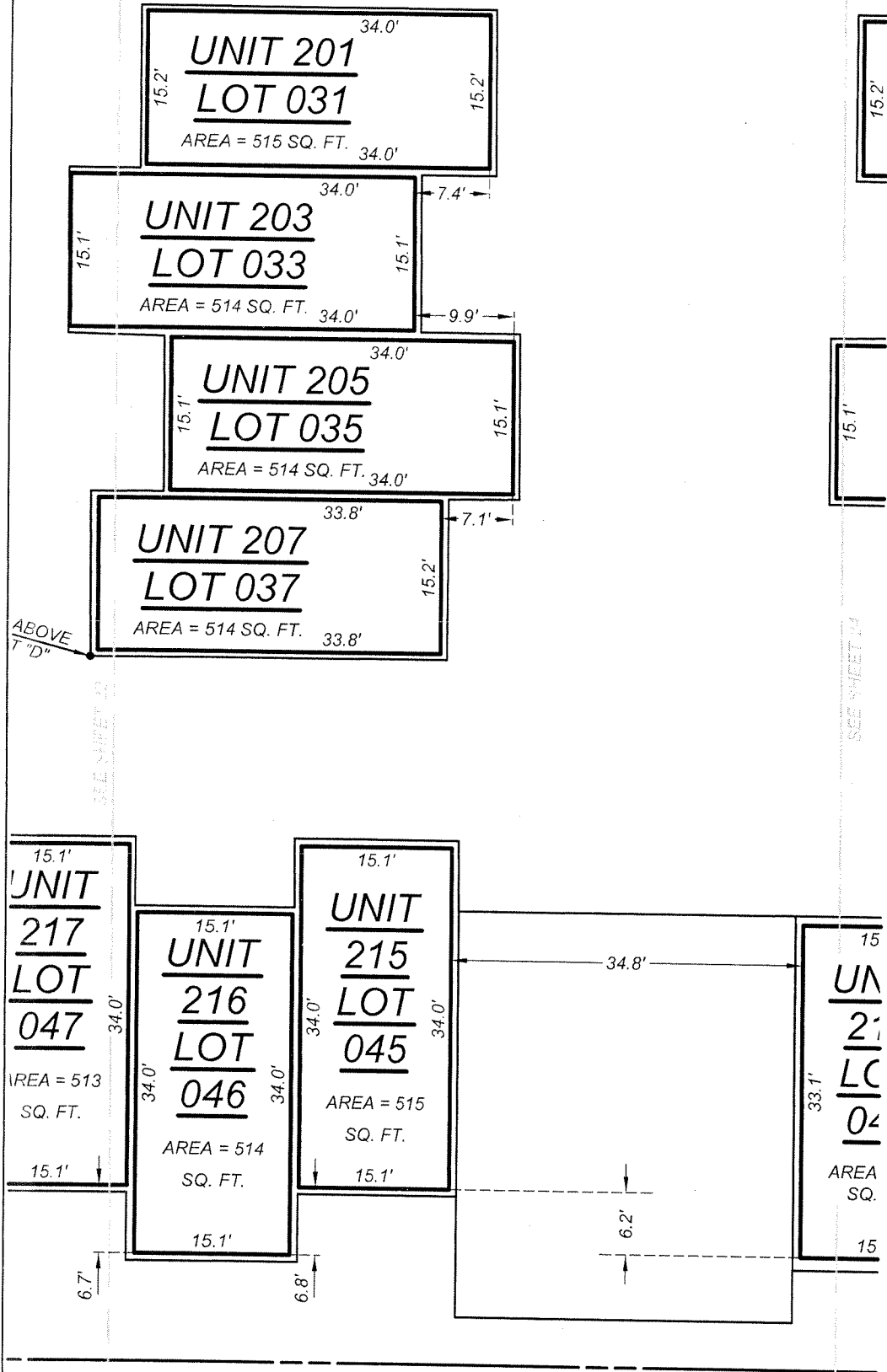

## 3RD FLOOR

UPPERMOST ELEVATION = 130.0'  
LOWERMOST ELEVATION = 122.1'

SURVEY: FTS DRAWN: OG CHECKED: HRF		<b>Frederick T. Seher &amp; Associates, Inc.</b> PROFESSIONAL LAND SURVEYORS 841 LOMBARD STREET, SAN FRANCISCO, CA PHONE (415) 921-7690 FAX (415) 921-7655	<b>1345 TURK STREET</b> <b>ASSESSOR'S BLOCK 0756, LOT 017</b> <b>CONDOMINIUM PLAN</b>
		JOB NO. 1288-08      DATED: APRIL, 2012	SCALE: 1" = 16'      SHEET NO. 23 OF 24

# TURK STREET

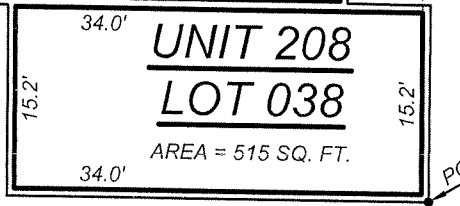
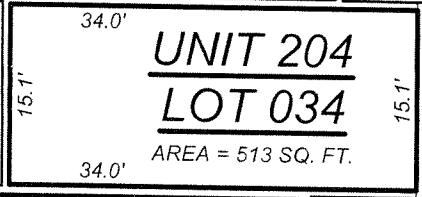
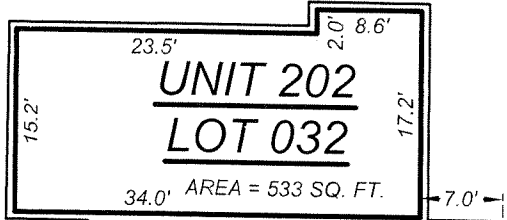

SEE SURVEY 23

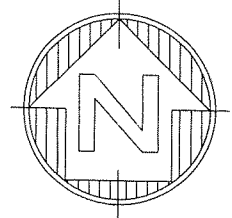
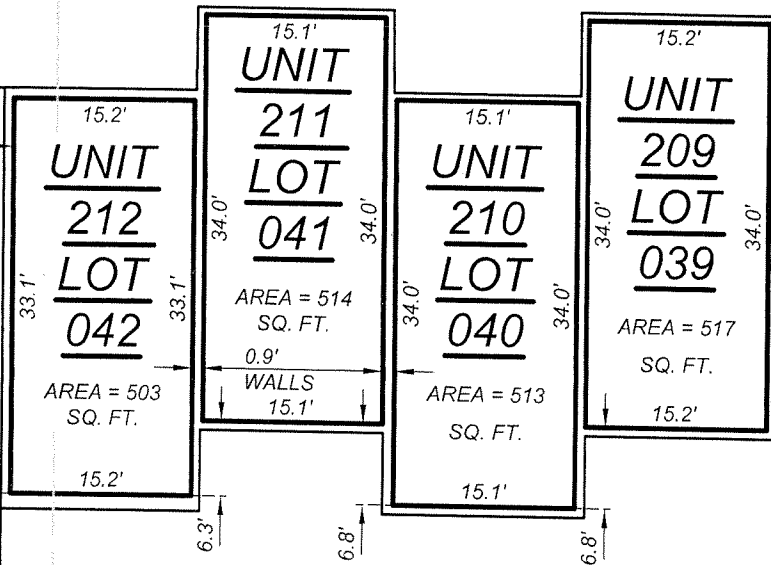

## 3RD FLOOR

UPPERMOST ELEVATION = 130.0'  
LOWERMOST ELEVATION = 122.1'

SURVEY: FTS  
DRAWN: OG  
CHECKED: HRF

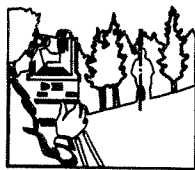

**Frederick T. Seher & Associates, Inc.**  
PROFESSIONAL LAND SURVEYORS  
841 LOMBARD STREET, SAN FRANCISCO, CA  
PHONE (415) 921-7690 FAX (415) 921-7655

1345 TURK STREET  
ASSESSOR'S BLOCK 0756, LOT 017  
CONDOMINIUM PLAN

JOB NO. 1288-08      DATED: APRIL, 2012

SCALE: 1" = 16'      SHEET NO. 24 OF 24



## EXHIBIT D

### UNIT MAINTENANCE AND REPAIR RESPONSIBILITIES<sup>1</sup>

#### ASSOCIATION

##### **Within the Unit:**

Building fire alarm system  
Structural repairs to load-bearing walls  
Fire sprinkler heads and systems  
(i) structural components of walls, ceilings, and floors, (ii) any portion of the frames of windows or exterior doors not exposed within a unit interior, or (iii) portions of plumbing, heating air conditioning, or electrical systems serving more than one unit.<sup>2</sup>

##### **Within the Common Area:**

Exterior door surfaces (including repainting or refinishing including terrace railing and surfaces)  
Dividing wall between terraces  
Elastomeric terrace membranes  
Cleaning exterior window surfaces  
Pipes and drains

#### CONDOMINIUM OWNER

##### **Within the Unit:**

All areas defined as a "Unit" in the General Notes on the Condominium Plan.

**Outside the Unit:** All areas defined as "Common Areas" as defined in the general Notes on the Condominium Plan and individual heating units on the roof which serve one unit only.

---

<sup>1</sup> The purpose of this exhibit is to informally describe the party responsible for maintaining and repairing items located within the Unit and within certain portions of the Common Area located in close proximity to the Unit. It is not intended to be an all-inclusive list and the terms in the body of the document shall control.

<sup>2</sup> Pursuant to Article IV Section 1.1 of the Declaration, these items shall be maintained and repaired by the Association.

**EXHIBIT E**

**FORM OF LIMITED EQUITY HOME OWNERSHIP  
PROGRAM DECLARATION OF RESTRICTIONS FOR  
FOR-SALE AFFORDABLE HOUSING UNITS AND  
OPTION TO PURCHASE AGREEMENT**

Free Recording Pursuant to  
Government Code Section 27383 at the  
Request of the Mayor's Office of Housing  
of the City and County of San Francisco

RECORDING REQUESTED BY AND  
WHEN RECORDED RETURN TO:

Mayor's Office of Housing as Successor Agency  
to the San Francisco Redevelopment Agency  
1 South Van Ness Avenue, 5<sup>th</sup> Floor  
San Francisco, California 94103  
Attn: HOUSING DIVISION

1345 Turk Street, Unit #000

(Space Above This Line for Recorder's Use)

Block 756, Lot 000

**LIMITED EQUITY HOME OWNERSHIP PROGRAM**  
**DECLARATION OF RESTRICTIONS FOR FOR-SALE AFFORDABLE**  
**HOUSING UNITS AND OPTION TO PURCHASE AGREEMENT**

**Section 1. Parties.**

THIS DECLARATION OF RESALE RESTRICTIONS AND OPTION TO PURCHASE AGREEMENT ("Declaration") is made as of \_\_\_\_\_, 2012, (the "Effective Date") by and between **Buyer, Vested Title** ("Owner") and the City and County of San Francisco, a municipal corporation, acting through the Mayor's Office of Housing, as successor to the Redevelopment Agency of the City and County of San Francisco (the "City"), a public body, corporate and politic, of the state of California. Owner is purchasing that certain real property in the City with a street address of **1345 Turk Street, Unit #000, San Francisco, California 94115**, and more particularly described on Exhibit A to the Grant Deed ("Property"). Capitalized terms used in this Declaration have the meanings given to them in Section 4 below.

**Section 2. Recitals.**

The following recitals of fact are a material part of this Declaration:

(a) The City has developed a program to provide home ownership opportunities to individuals and families with low and moderate incomes by offering homes for sale at prices which are below those otherwise prevailing in the market;

(b) The City's intent is to preserve the affordability of such homes by restricting the resale price;

- (c) Such homes constitute a valuable community resource; and
- (d) It is necessary, proper and in the public interest for the City to protect and preserve this resource by administering occupancy and resale controls by means of this Declaration.

NOW, THEREFORE, in consideration of the substantial economic benefits inuring to Owner and the public purposes to be achieved under the affordable housing program, Owner and the City agree as follows:

**Section 3. Owner's Affordable Purchase Price.**

The Owner's Affordable Purchase Price for the Property described in Section 1, above, is **\$000,000**. This is the purchase price which is affordable to a household earning **00.00%** of Area Median Income, adjusted for a Household Size of one person for one-bedroom units, and one person per bedroom plus one for all other unit sizes, using a five percent (5%) down payment and a thirty (30)-year, fixed rate mortgage with commercially reasonable points and fees, and with a total annual payment for principal, interest, taxes, insurance and homeowner's association dues which does not exceed 33% of the household's Gross Annual Income. The mortgage interest rate used in the calculation shall be the higher of 1) the ten-year rolling average interest rate, as calculated by the City (or its successor) based on data provided by Fannie Mae, Freddie Mac, or an equivalent, nationally recognized mortgage financing institution, or 2) the current, commercially reasonable rate available through an City-approved lender.

**Section 4. Definitions.**

As used in this Declaration, the capitalized terms set forth below shall have the following meanings:

- (a) "Addendum to Deed of Trust" means the supplemental document to the Deed of Trust, executed by a Qualified Purchaser in favor of the City.
- (b) "Affordable Purchase Price" for Owner is defined in Section 3.
- (c) "City" is defined in Section 1.
- (d) "City Note" is the promissory note executed by Owner in favor of the City, which is secured by a Deed of Trust executed by Owner in favor of the City, in the form attached.
- (e) "Area Median Income" ("AMI") means the median income for a household, adjusted solely for Household Size, residing in the City, as determined by the City pursuant to publications issued by the United States Department of Housing and Urban Development for the San Francisco Primary Metropolitan Statistical Area, from time to time.

(f) “Broker” means a real estate broker licensed by the State of California Department of Real Estate and approved by the City to assist Owner in identifying Qualifying Purchasers for the Transfer of the Property.

(g) “Buyer Acknowledgement” means the acceptance of terms and conditions in the City’s Loan Disclosure Information form.

(h) “Capital Improvements” is defined in Section 10.1.

(i) “Catastrophic Illness” means an illness or injury that incapacitates Owner for an extended period of time, or that incapacitates a member of Owner’s family, which incapacity requires Owner to take time off from work for an extended period to care for that family member, and taking extended time off from work creates a financial hardship for Owner because he or she has exhausted all of his or her sick leave and other paid time off.

(j) “Certificate Holder” means those households with a valid Certificate of Preference issued by the City that entitles the holder to receive preference in consideration for housing due to displacement by prior redevelopment activities.

(k) “City” means the City and County of San Francisco.

(l) “Closing Costs” means the reasonable and customary costs incurred by Owner in transferring the Property.

(m) “Damage” means deficiencies in the Property occurring during Owner’s ownership of the Property, including without limitation: (1) violations of applicable building, plumbing, electric, fire or housing codes; (2) needed repair to appliances furnished to Owner upon purchase of the Property; (3) holes and other defects (except for holes from picture hangers) in walls, ceilings, floors, doors, windows, screens, carpets, drapes, countertops and similar appurtenances; and (4) repairs needed, as determined by City, to put the Property into saleable condition, including without limitation cleaning and painting.

(n) “DDA” is defined in Section 5.1.

(o) “Declaration” is defined in Section 1.

(p) “Deed of Trust” means one or more Deeds of Trust on this Property, executed by Owner in favor of the City.

(q) “Developer” is defined in Section 5.1.

(r) “Domestic Partner” means any person who has or enters into a domestic partnership currently registered with a governmental body pursuant to State or local law authorizing such registration.

(s) “Down Payment Assistance Loan” is a loan of down payment funds made by the City to Owner for purchase of the Property.

(t) “Effective Date” is defined in Section 1.

(u) “Events of Default” are defined in Section 11.1.

(v) “Fair Market Value” means the cash purchase price for the Property that a willing buyer would pay to a willing seller at the time of sale, neither being under a compulsion to buy or sell, as determined by an independent, MAI-certified appraiser who has experience in residential appraisals in San Francisco.

(w) “Household Size” means the number of persons for whom the Property will be a Principal Residence. The Affordable Purchase Price shall be established by using a Household Size that assumes occupancy by one person for one-bedroom units. For all other units, the assumption is occupancy by one person per bedroom plus one. Household Size for occupancy shall be a minimum of one person per bedroom.

(x) “Grant Deed” is defined in Section 8.1(b).

(y) “Gross Annual Income” means pre-tax money earned annually by a household including overtime pay, commissions, dividends, and any other source of income.

(z) “Income Certification” has the meaning set forth in Section 7.

(aa) “Notice” is defined in Section 13.4.

(bb) “Notice of Proposed Transfer” is defined in Section 7.1.

(cc) “Occupancy Certificate” is defined in Section 13.3.

(dd) “Owner” is defined in Section 1, and upon Owner’s death includes the personal representative administering the Owner’s estate.

(ee) “Owner’s Proceeds” means the amount due to Owner upon Transfer of the Property to a Qualifying Purchaser or upon exercise of the City’s Purchase Option, according to the terms of this Declaration.

(ff) “Permitted Exceptions,” means those title exceptions that are listed on the Permitted Exceptions attachment.

(gg) “Principal Residence” means the location at which an individual resides for at least ten (10) months out of each calendar year or such shorter period of time as the City, in its sole discretion, shall determine.

(hh) “Property” is defined in Section 1.

(ii) “Purchase Option” is defined in Section 9.1.

(jj) “Purchase Option Assignee” is defined in Section 9.3.

(kk) “Qualifying Purchaser” means persons and families who are first time homebuyers as defined in Internal Revenue Service Code and approved by the City whose Gross Annual Income, adjusted for Household Size, does not exceed 00.00% of Area Median Income.

(ll) “Repair Costs” means the costs to repair Damage to the Property.

(mm) “Resale Affordable Price” means a purchase price which is affordable to a household earning 00.00% of current Area Median Income, adjusted for a Household Size of one person for one-bedroom units and one person per bedroom plus one for all other unit sizes, using a five percent (5%) down payment and a thirty (30)-year fixed mortgage with commercially reasonable points and fees, and with a total annual payment for principal, interest, taxes, insurance and homeowner’s association dues which does not exceed 33% of the household’s Gross Annual Income. The mortgage interest rate used in the calculation shall be the higher of 1) the ten-year rolling average of interest rates, as calculated by the City (or its successor) based on data provided by Fannie Mae, Freddie Mac, or an equivalent, nationally recognized mortgage lending institution, or 2) the current, commercially reasonable rate available through an City-approved lender.

(nn) “Senior Lender” means any Lender to which the City has agreed to subordinate its interests in the Property.

(oo) “Senior Lien” means any deed of trust for the purpose of securing a loan from the Senior Lender to finance or refinance the purchase of the property.

(pp) “Transfer” means any voluntary or involuntary sale, assignment or transfer of any interest in the Property.

(qq) “Unauthorized Transfer” is defined in Section 11. Related Documents.

## **Section 5.**

**5.1 Disposition and Development Agreement.** The City and MSPDI Turk, LLC, a California limited liability company (“Developer”) entered into that certain Disposition and Development Agreement, dated for reference purposes only as of February 2, 2010 and recorded on April 22, 2010 as Document No. 2010-1955753-00 in the City’s Official Records (“DDA”), including the Limited Equity for For-Sale Affordable Housing Program attached thereto as Attachment F to the DDA (the “Housing Program”), concerning the development of affordable housing units. The DDA and the

Housing Program are on file with the City as public records and are incorporated herein by reference. Under the DDA, and the Housing Program, the Property is income and price restricted to be affordable to persons or households earning not more than 120% of Area Median Income. This Declaration is being executed and recorded in accordance with the DDA and partially satisfies the requirements therein.

**5.2 Former Western Addition Redevelopment Project Area Plan.** The Property is in the City within the Former Western Additional Redevelopment Area Plan, adopted by Ordinance No. 113-06, on May 16, 2006.

**5.3 City Note and Deed of Trust.** Owner executed an City Note in favor of City, dated \_\_\_\_\_, 2011, secured by a Deed of Trust and Addendum to Deed of Trust on the Property.

**Section 6. Affordable Restrictions.**

**6.1 Restrictions.** Owner shall own and occupy the Property as Owner's Principal Residence, and Owner shall not lease the Property, or any portion thereof, without the City's prior written consent. Owner shall submit to the City on an annual basis a certification that Owner has occupied the Property as Owner's Principal residence for at least ten (10) months in the preceding year.

**6.2 Term.** This Declaration shall remain in effect for forty-five (45) years from the Effective Date until such time as the Property is Transferred pursuant to the terms of this Declaration, at which time a declaration with the same form and substance as this Declaration shall become effective for forty-five (45) years from the effective date of such declaration. Upon the expiration of this Declaration due to completion of the 45-year Term, Owner must repay to the City the difference between the Resale Affordable Price and the Fair Market Value, as determined at the completion of the Term. In lieu of this payment to the City, Owner may renew the Term of this Agreement for an additional forty-five (45) years.

**6.3 Owner Representations and Warranties.** In applying to purchase the Property, Owner submitted an Income Certification form. Owner acknowledges that reasonable efforts may be made to verify such Income Certification, including without limitation calling Owner's employers or other sources of income to confirm the income shown. Owner represents and warrants to the City that the Income Certification and any financial and other information Owner previously provided to City for the purpose of qualifying to purchase the Property was true and correct at the time it was given and remains true and correct as of the date of this Declaration.

## **Section 7. Transfer Procedures.**

**7.1 Notice of Proposed Transfer.** Except as provided in Sections 7.5 and 7.6(a), if Owner desires to Transfer the Property, Owner shall deliver written notice to City ("Notice of Proposed Transfer"), and City shall calculate the Resale Affordable Price and notify Owner of the same.

**7.2 Priority to Certificate Holders.** An Owner may transfer the Property only to a Qualifying Purchaser or the City. The City shall give notice to Certificate Holders who shall have priority in purchasing the Property over all other Qualified Purchasers, except for transferees under Section 7.5 and 7.6(a) and the City. If no Certificate Holders express interest in purchasing the Property or are not otherwise qualified, then Owner shall market the Property as set forth in Section 7.3 below.

**7.3 Marketing the Property.** Owner shall work with Broker to locate a Qualifying Purchaser for Transfer of the Property at the Resale Affordable Price. Owner and Broker shall use diligence and good faith in marketing the Property as evidence by all of the following:

- Listing the Property on the MLS Listing;
- Advertising the Property in the Real Estate section of at least two (2) newspapers of general circulation in the City;
- Conducting at least two (2) open houses of the Property; and
- Requesting that the City list the Property on the City's website.

If Owner and Broker, acting diligently and in good faith, are unable to locate a Qualifying Purchaser after one hundred and fifty (150) days from the date of City's receipt of the Notice of Proposed Transfer, then the percentage of AMI defining Qualifying Purchasers shall be increased to 150% of the AMI set forth in Section 3., up to a maximum of 120% of AMI. The Resale Affordable Purchase Price shall remain the same, unless adjusted pursuant to Section 8.4.

**7.4 Inspection.** Within thirty (30) days after the City's receipt of the Notice of Proposed Transfer, City shall have the right to enter and inspect the Property. The City shall give Owner twenty-four (24) hours prior written notice before conducting an inspection. The City may inspect the Property to determine if any Damage exists. In the event any Damage is noted, the City shall determine the Repair Costs and shall deliver written notice to Owner specifying the Damage and the Repair Costs. Owner shall either: (a) repair the Damage at Owner's cost, or (b) cause the escrow agent at closing to pay the Repair Costs to City from Owner's Proceeds, as provided in Section 8.3. If Owner elects to repair the Damage, the City shall have the right to re-inspect the Property under the terms of this Section 7.4 after the repairs are complete. If the City determines in the City's sole discretion that Damage still remains, Owner shall cause the escrow agent at

closing to pay the remaining Repair Costs to the City, but only to the extent such funds are available after payment of the Senior Lien. If Owner elects to repair the Damage, all repairs and the re-inspection shall be completed without extending the closing date, unless extended by mutual written agreement of both the City and Owner.

**7.5 Transfer to Spouse or Domestic Partner.** If an Owner marries or becomes a Domestic Partner after purchasing the Property, the spouse or Domestic Partner may become a co-Owner. An Owner intending to add a spouse or Domestic Partner as a co-Owner must present his or her marriage certificate or Domestic Partnership registration to the City for review, and the proposed co-Owner shall execute an addendum to this Declaration and any other City documents related to the Property by which the co-Owner shall assume the same rights and responsibilities with respect to those documents as the Owner.

**7.6 Transfer Upon Owner's Death.**

(a) Upon Owner's death, the Property may be Transferred to any co-Owner previously approved by the City without further City approval, but such co-Owner shall notify City within thirty (30) days of the Transfer.

(b) Upon the death of Owner and all City approved co-Owners, the Property may be Transferred by inheritance, will, or any other function of law to a Qualifying Purchaser. The proposed transferee shall submit an Income Certification form and any other information reasonably requested by the City to verify that the proposed transferee meets the requirements for a Qualifying Purchaser. The City shall have forty-five (45) days after receipt of all required information to determine whether the proposed transferee is a Qualifying Purchaser. If the City determines that the proposed transferee is a Qualifying Purchaser, the Property may be Transferred to the proposed transferee for no consideration. The proposed transferee shall execute a new Declaration and any other City documents related to the Property by which the proposed transferee shall assume the same rights and responsibilities with respect to those documents as the Owner. If the City determines that the proposed transferee is not a Qualifying Purchaser, the Property shall be Transferred pursuant to Sections 7.1 – 7.4, inclusive.

**Section 8. Closing.**

**8.1 Conditions to Closing.** Except as provided in Sections 7.5, 7.6(a) and Transfers by foreclosure or the Senior Lender's acceptance of a deed in lieu of foreclosure, all Transfers shall take place through an escrow with a mutually acceptable escrow company. It shall be a condition to closing, other than a Transfer to a co-Owner pursuant to Sections 7.5 or 7.6(a), that the escrow agent involved in the closing has received the following:

(a) Written confirmation from the City of the Resale Affordable Price and either (i) the identity of the Qualifying Purchaser or (ii) notification that the City is exercising the Purchase Option;

(b) A standard title company form grant deed, executed and acknowledged by Owner (or the City as attorney in fact for Owner) granting the Property to the Qualifying Purchaser (“Grant Deed”), which shall be recorded in the City’s Official Records;

(c) A declaration with the same form and substance as this Declaration executed and acknowledged by the Qualifying Purchaser and the City, which shall be recorded in the City’s Official Records;

(d) An City Note secured by a Deed of Trust and Addendum to Deed of Trust, executed by the Qualifying Purchaser on the City’s standard forms, which Deed of Trust and Addendum shall be recorded in the City’s Official Records; and

(e) A signed copy of the Buyer Acknowledgement contained in the Loan Disclosure Information.

**8.2 Closing Procedures For Sale to Qualifying Purchaser.** At closing, Owner shall convey the Property to the Qualifying Purchaser by Grant Deed. Owner shall cause a mutually acceptable title company to issue to the Qualifying Purchaser a CLTA standard coverage owner’s form of title insurance policy in the amount of the Resale Affordable Price insuring title to the Property vested in the Qualifying Purchaser, subject only to standard printed form exceptions, the City’s Deed of Trust and exclusions, liens for current taxes and assessments not yet due or payable, the new declaration and such other matters as were exceptions to title as of \_\_\_\_\_ [date of sale to first Owner] or are accepted by the Qualifying Purchaser in writing, as set forth in the Permitted Exceptions attachment. All closing costs and title insurance premiums shall be paid pursuant to the custom in the City.

**8.3 Owner’s Proceeds.** The value of the Owner’s Proceeds from a Transfer of the Property shall be calculated as follows. Owner’s Proceeds equal:

- (a) The Resale Affordable Price;
- (b) Less the amount necessary to release the Senior Liens;
- (c) Less Closing Costs;
- (d) Less any Repair Costs due to the City pursuant to Section 7.4;
- (e) Plus the depreciated value of Capital Improvements.

**8.4 Resale Affordable Price.**

(a) Notwithstanding anything in this Declaration to the contrary, if the Resale Affordable Price is less than the original principal amount of the Senior Liens, then the

City may increase the percentage of AMI to a level sufficient to allow for a Resale Affordable Price which covers the original principal amount of the Senior Liens, up to a maximum of 120% of AMI. If, after adjustment of the Resale Affordable Price described above, if any, the Resale Affordable Price is less than the sum of the Owner's Affordable Price plus the Closing Costs, then the City through its Executive Director as authorized in Resolution No. 73-2000 dated May 23, 2000 shall deposit into escrow the funds necessary to cover the Owner's original down payment funds and Closing Costs. Such deposit into escrow shall be in addition to City's deposit into escrow of the depreciated value of the Capital Improvements. After such adjustment, the value of the Owner's Proceeds shall be calculated according to Section 8.3.

(b) City and Owner acknowledge that the Senior Lien holder will not release the Senior Lien unless it is repaid in full. If the Senior Lien holder does not release the Senior Lien because the Owner has not or cannot fully repay it, then the sale will be cancelled or the Owner will be in default under the Senior Lien.

## **Section 9. City's Purchase Option.**

**9.1 Grant of Option.** Owner grants to City an option to purchase the Property upon the occurrence of an Event of Default under Section 11.1 ("Purchase Option").

**9.2 Exercise of Option.** City may exercise the Purchase Option as follows:

(a) If the Purchase Option is triggered as a result of an Event of Default under Sections 11.1(a) – (d), then the City may exercise the Purchase Option within ninety (90) days after the City gives written notice of default to Owner.

(b) If the Purchase Option is triggered as a result of Owner's default under the Senior Lien as defined in Section 11.1(e), then the City may exercise the Purchase Option by giving written notice to Owner and Senior Lender at any time prior to five (5) business days before the date of a foreclosure sale, as the same may be postponed from time to time, under the Senior Lien pursuant to California Civil Code § 2924f. Though the Senior Lender shall not be required to do so, the Senior Lender shall endeavor to provide the City with a copy of any notice of default that it issues to Owner.

**9.3 Assignment of Purchase Option.** Prior to or after exercise of the Purchase Option, the City may assign the Purchase Option to a governmental City, non-profit organization, or a Qualifying Purchaser ("Purchase Option Assignee"), who shall be subject to this Declaration.

**9.4 Grant of Power of Attorney.** Owner hereby grants to the City an irrevocable power of attorney coupled with an interest to act on Owner's behalf to execute, acknowledge and deliver any and all documents relating to the Purchase Option.

**9.5 Non-Liability of City.** The City shall not be held liable by reason of its exercise or non-exercise of the Purchase Option.

## **Section 10. Capital Improvements; Maintenance.**

**10.1 Capital Improvements.** A “Capital Improvement” is a permanent improvement to the Property made during Owner’s ownership of the Property which: (a) has a value in excess of one-half of one percent (0.5%) of the Affordable Purchase Price originally paid by Owner but less than ten percent (10%) of the Affordable Purchase Price originally paid by Owner; (b) has a useful life of greater than five (5) years subsequent to the proposed Transfer by Owner; and (c) has been made with all required permits and approvals, including without limitation homeowner’s association and governmental approvals obtained prior to the construction or installation of the Capital Improvement(s).

**10.2 Credits for Capital Improvements.** Owner shall receive credit at the time of Transfer for Capital Improvements made to the Property as follows:

(a) At least thirty (30) days prior to the date of Transfer, Owner shall deliver to the City a list of the Capital Improvement(s), if any, made to the Property. The City shall determine whether the proposed improvements qualify as Capital Improvement(s), as defined in Section 10.1.

(b) The value of Capital Improvements shall equal the cost of all Capital Improvements with each improvement depreciated by a factor of seven percent (7%) per year from the date of the Capital Improvement’s completion.

**10.3 Maintenance.** Owner shall not destroy or damage the Property, allow the Property to deteriorate, or commit waste on the Property. Owner shall maintain the Property in compliance with all applicable laws, ordinances and regulations and in a good and clean condition and all appliances and fixtures shall be in good working order.

## **Section 11. Default and Remedies.**

**11.1 Events of Default.** The occurrence of any one of the following events or circumstances shall constitute an “Event of Default” by Owner under this Declaration.

(a) Owner has actually Transferred or attempted to Transfer the Property in violation of the covenants and restrictions contained in this Declaration (“Unauthorized Transfer”).

(b) The City has determined in the City’s sole discretion that the Property is not Owner’s Principal Residence.

(c) Owner fails to pay real estate taxes, assessments or homeowner’s association dues, when due or Owner fails to maintain insurance in such amounts as required under this Declaration; or Owner places any mortgages, encumbrances or liens upon the Property in violation of this Declaration; and such event or condition shall not

have been cured within thirty (30) days following the date of written notice to cure by the City to Owner.

(d) Owner fails to perform any other agreements or obligations on Owner's part to be performed under this Declaration, and such failure continues for thirty (30) days following the date of written notice to cure by the City to Owner, or in the case of a default not susceptible of cure within thirty (30) days, Owner fails to promptly commence such cure within thirty (30) days and thereafter fails to diligently prosecute such cure to completion.

(e) Owner causes or permits a default under the Senior Lien and fails to cure the same in accordance with the cure provisions in the Senior Lien.

(f) Owner is in default of a term of the City Note and/or the Deed of Trust.

**11.2 Remedies.** Upon the occurrence of an Event of Default by Owner, City may exercise any or all of the remedies set forth below:

(a) City shall have the right to exercise the Purchase Option;

(b) City shall have the right to institute an action for specific performance of the terms of this Declaration, for an injunction prohibiting a proposed Transfer in violation of this Declaration, or for a declaration that a Transfer is void; and

(c) City shall have the right to institute an action for foreclosure on its Deed of Trust and/or to accept a deed in lieu of foreclosure.

(d) City shall have the right to exercise all other remedies permitted by law or at equity.

## **Section 12. Lender Provisions.**

**12.1 Purposes of Financing.** Subject to the City's prior written approval, Owner may encumber title to the Property for the sole purpose of securing (a) purchase money financing, (b) refinancing (but only up to the amount of the original Senior Liens), or (c) refinancing up to the amount of the original Senior Liens, plus fifty percent (50%) of the value of the Resale Affordable Price less the Owner's Affordable Purchase Price. Refinancing under option (c), above, shall be permitted only for making Capital Improvements to the Property, meeting post-secondary educational expenses incurred by a household member after the date of purchase, meeting the costs of an Owner's or Owner's immediate family member's Catastrophic Illness, or securing funds required to implement a dissolution of marriage or domestic partnership agreement. Owner shall not cause or permit any other mortgages, encumbrances or liens upon the Property. Owner shall submit to the City on an annual basis a certification that Owner has not refinanced the Property in violation of this Section 12.1.

**12.2 Subordination.** This Declaration shall be subordinate to the City-approved Senior Lien.

**12.3 Default and Foreclosure.** Owner shall provide a copy of any notice of default under the Senior Lien to the City within three (3) days of Owner's receipt. In the event of any default under the Senior Lien, City, in addition to any other rights and remedies it may have under this Declaration, at law or in equity, shall have the right to:

- (a.) cure such default pursuant to Section 12.4;
- (b.) exercise its Purchase Option pursuant to Section 9.2(b); or
- (c.) foreclose its Deed of Trust on the Property.

City's rights under this Section 12.3 shall not prevent the Senior Lender from commencing a judicial or nonjudicial foreclosure of the Senior Lien. If the City, in its sole discretion, does not act pursuant to Sections 12.3(a-b) above, and the Senior Lender acquires the Property through foreclosure or acceptance of a deed-in-lieu of foreclosure, future sales of the Property shall not be subject to the resale restrictions provided herein.

**12.4 Right to Cure.** Although the City has no obligation to do so, the City may perform any act required of Owner in order to prevent a default under, or an acceleration of the indebtedness secured by, the Senior Lien or the commencement of any foreclosure or other action to enforce the collection of such indebtedness. If the City elects to cure any such default, Owner shall pay the expenses incurred by the City in effecting any cure upon demand within thirty (30) days, together with the interest thereon at the maximum interest rate permitted by law. Failure of Owner to timely reimburse the City shall constitute an Event of Default under Section 11.1(d).

### **Section 13. Miscellaneous.**

**13.1 Damage and Destruction; Condemnation; Insurance.** If the Property is condemned or the improvements located on the Property are damaged or destroyed, all proceeds from insurance or condemnation shall be distributed in accordance with this Section 13.1, subject to the requirements of the Senior Lien. Insurance shall be maintained in the types and amounts required under the Senior Lien. Unless Owner, the City, and Senior Lender otherwise agree in writing, insurance proceeds shall be applied to restore or repair the Property damaged. If Owner, the City and Senior Lender determine that restoration or repair cannot be made, or if the Property is condemned, the insurance or condemnation proceeds shall first be allocated to pay the outstanding value of the Senior Lien and all associated fees of the Senior Lender, with the balance distributed between the Owner and City as follows. The proceeds attributable to the Property shall be multiplied by a fraction. The numerator is the Resale Affordable Price as calculated under this Declaration and the denominator is the Fair Market Value of the Property as of the date immediately prior to the damage, destruction or condemnation.

The resulting amount shall be allocated to the Owner and the balance shall be allocated to the City.

**13.2 No Discrimination; Lead-Based Paint Prohibition.** Owner shall comply with all applicable laws and regulations regarding non-discrimination and lead-based paint prohibitions.

**13.3 Owner Occupancy Verification.** To insure compliance with this Declaration's requirement that Owner use the Property as his/her Principal Residence, Owner shall provide City with a completed Occupancy Certificate ("Occupancy Certificate"), to be provided by the City by February 1 of each year for the previous calendar year.

**13.4 Notices.** Any notice, demand or other communication required or permitted to be given under this Declaration (a "Notice") by either party to the other party shall be in writing and sufficiently given or delivered if transmitted by (a) registered or certified United States mail, postage prepaid, return receipt requested, (b) personal delivery, or (c) nationally recognized private courier services, in every case addressed as follows:

If to City: Mayor's Office of Housing  
of the City and County of San Francisco  
1 South Van Ness Avenue, 5<sup>th</sup> floor  
San Francisco, California 94103  
Attention: Executive Director

If to Owner: 1345 Turk Street, Unit # \_\_\_\_\_  
San Francisco, CA 94115

Any such Notice transmitted in accordance with this Section 13.4 shall be deemed delivered upon receipt, or upon the date delivery was refused. Any party may change its address for notices by written Notice given to the other party in accordance with the provisions of this Section 13.4.

**13.5 Remedies Cumulative.** Subject to applicable law, the City's rights and remedies, whether provided by law, in equity or by this Declaration, shall be cumulative, and the exercise of any one or more of such rights or remedies shall not preclude the exercise of any other or further rights or remedies for the same or any other default or breach. No waiver with respect to the performance of any of Owner's obligations shall be effective except to the extent the particular obligation is expressly waived, nor shall it be a waiver with respect to any other rights or remedies of any other of Owner's obligations.

**13.6 Attorneys' Fees for Enforcement.** If any action or legal proceeding is instituted by Owner or the City arising out of this Declaration, the prevailing party therein shall recover reasonable attorneys' fees and costs in connection with such action or proceeding. For purposes of this Agreement, reasonable fees of any in-house counsel

for the City shall be based on the fees regularly charged by private attorneys with an equivalent number of years of professional experience in the subject matter area of the law for which the City's in-house counsel's services were rendered who practice in law firms located within the City.

**13.7 Integration.** This Declaration constitutes an integration of the entire understanding and agreement of the Owner and the City with respect to the subject matter hereof. Any representations, warranties, promises, or conditions, whether written or oral, not specifically and expressly incorporated in this Declaration, shall not be binding on any of the parties, and Owner and the City each acknowledge that they have not relied, in entering into this Declaration, on any representation, warranty, promise or condition, not specifically and expressly set forth in this Declaration. All prior discussions and writings have been, and are, merged and integrated into, and are superseded by, this Declaration.

**13.8 Severability.** In the event that any provision of this Declaration is determined to be illegal or unenforceable, such determination shall not affect the validity or enforceability of the remaining provisions hereof, all of which shall remain in full force and effect.

**13.9 Successors and Assigns.** This Declaration shall be binding upon and inure to the benefit of the successors and assigns of the City. The City may assign or transfer its rights under this Declaration upon thirty (30) days written notice to Owner. It is expressly agreed by Owner that Owner may assign his or her rights to this Declaration only by Transfer pursuant to Section 7 or by the City's exercise of the Purchase Option pursuant to Section 9.

**13.10 Headings.** The headings within this Declaration are for the purpose of reference only and shall not limit or otherwise affect any of the terms of this Declaration.

**13.11 Time for Performance.** Time is of the essence in the performance of the terms of this Declaration. All dates for performance (or cure) shall expire at 5:00 p.m. on the performance or cure date. Any performance date which falls on a Saturday, Sunday or City holiday is automatically extended to the next City working day.

**13.12 Amendments.** Any modification or waiver of any provision of this Declaration or any amendment thereto must be in writing and signed by a person or persons having authority to do so, on behalf of both the City and Owner.

**13.13 Controlling Agreement.** Owner covenants that Owner has not executed and will not execute any other agreement with provisions contradictory to or in opposition to the provisions of this Declaration. Owner understands and agrees that this Declaration shall control the rights and obligations between Owner and the City.

**13.14 Governing Law.** This Declaration shall be governed by, and construed and enforced in accordance with, the internal laws of the state of California.

**13.15 Recordation.** Owner shall cause this Declaration to be recorded in the City's Official Records.

IN WITNESS WHEREOF, Owner and the City have executed this Declaration as of the date written above.

**CITY:**

Mayor's Office of Housing of the  
City and County of San Francisco, a  
public body, corporate and politic

**OWNER:**

\_\_\_\_\_  
**Buyer Name**

By: \_\_\_\_\_  
Olson Lee  
Director

\_\_\_\_\_  
**Buyer Name**

ALL SIGNATURES MUST BE NOTARIZED.

----- Attach All Purpose California Notary Acknowledgment -----

Free Recording Pursuant to Government  
Code Section 27383 at the Request of the  
Mayor's Office of Housing of the City and  
County of San Francisco

When recorded, mail to:  
Mayor's Office of Housing as Successor to  
the San Francisco Redevelopment Agency  
1 South Van Ness Avenue, 5<sup>th</sup> Floor  
San Francisco, California 94103  
Attention: Housing Division

----- Space Above This Line for Recorder's Use -----

1345 Third Street, Unit #000  
Assessor's Block 756, Lot 000

**SHORT FORM DEED OF TRUST AND ASSIGNMENT OF RENTS**

**THIS DEED OF TRUST**, made on \_\_\_\_\_, **2012**, between **Name, Vested Title**, ("TRUSTOR" or "OWNER"), whose address is **1345 Turk Street, Unit #000, San Francisco, California 94115**, and **Old Republic Title Company, a California corporation**, ("TRUSTEE"), and the City and County of San Francisco, a municipal corporation, acting through the Mayor's Office of Housing, as successor to the Redevelopment Agency of the City and County of San Francisco (the "City"), a public body, corporate and politic, whose address is 1 South Van Ness Avenue, 5<sup>th</sup> Floor, San Francisco, California 94103, ("**CITY**" or "**BENEFICIARY**"),

**WITNESSETH:** That Trustor IRREVOCABLY GRANTS, TRANSFERS AND ASSIGNS to TRUSTEE IN TRUST, WITH POWER OF SALE, that property in San Francisco County, California, described as Attachment "A" attached hereto and made a part hereof.

TOGETHER WITH the rents, issues and profits thereof, SUBJECT, HOWEVER, to the right, power and authority given to and conferred upon Beneficiary by paragraph (10) of the provisions incorporated herein by reference to collect and apply such rents, issues and profits.

**For the Purpose of Securing:** 1. Performance of each agreement of Trustor incorporated by reference or contained herein. 2. Payment of the indebtedness evidenced by one promissory note of even date herewith, and any extension or renewal thereof, executed by Trustor in favor of Beneficiary or order. 3. Payment of such further sums as the then record owner of said property hereafter may borrow from Beneficiary, when evidenced by another note (or notes) reciting it is so secured.

**To Protect the Security of this Deed of Trust, Trustor Agrees:**

By the execution and delivery of this Deed of Trust and the note secured hereby, that provisions (1) to (14), inclusive, of the fictitious deed of trust recorded in Santa Barbara County and Sonoma County October 18, 1961, and in all other counties October 23, 1961, in the book and at the page of Official Records in the office of the county recorder of the county where said property is located, noted below opposite the name of such county, viz:

INITIALS \_\_\_\_\_

COUNTY BOOK PAGE  
San Francisco A332 905

which provisions, identical in all counties, (printed on the attached unrecorded pages) are hereby adopted and incorporated herein and made a part hereof as fully as though set forth herein at length; that Trustor will observe and perform said provisions; and that the references to property, obligations and parties in said provisions shall be construed to refer to the property, obligations, and parties set forth in this Deed of Trust.

The undersigned Trustor requests that a copy of any Notice of Default and of any Notice of Sale hereunder be mailed to the address hereinbefore set forth.

STATE OF CALIFORNIA  
COUNTY OF SAN FRANCISCO

On \_\_\_\_\_, before me,  
\_\_\_\_\_, Notary Public,  
personally appeared, **Buyer Name**,  
proved to me on the basis of satisfactory  
evidence, to be the person(s) whose name  
is/are subscribed to the within instrument  
and acknowledged to me that he/she/they  
executed the same in his/her/their  
authorized capacity(ies), and that by  
his/her/their signature(s) on the instrument  
the person(s), or the entity upon behalf of  
which the person(s) acted, executed the  
instrument.

\_\_\_\_\_

**Buyer Name**

\_\_\_\_\_

**Buyer Name**

I certify under penalty of perjury under  
the laws of the State of California that the  
foregoing paragraph is true and correct.

Witness my hand and official seal.

Signature \_\_\_\_\_

**DO NOT RECORD**

The following is a copy of provisions (1) to (14), inclusive, of the fictitious deed of trust, recorded in each county in California, as stated in the foregoing Deed of Trust and incorporated by reference in said Deed of Trust as being a part thereof as if set forth at length therein.

**TO PROTECT THE SECURITY OF THIS DEED OF TRUST, TRUSTOR AGREES:**

- (1) To keep said property in good condition and repair; not to remove or demolish any building thereon; to complete or restore promptly and in good and workmanlike manner any building which may be constructed, damaged or destroyed thereon and to pay when due all claims for labor performed and materials furnished therefor; to comply with all laws affecting said property on requiring any alterations or improvements to be made thereon; not to commit or permit waste thereof; not to commit, suffer or permit any act upon said property in violation of law; to cultivate, irrigate, fertilize, fumigate, prune and do all other acts which from the character or use of said property may be reasonably necessary, the specific enumerations herein not excluding the general.
- (2) To provide, maintain and deliver to Beneficiary fire insurance satisfactory to and with loss payable to Beneficiary. The amount collected under any fire or other insurance policy may be applied by Beneficiary upon any indebtedness secured hereby and in such order as Beneficiary may determine, or at option of Beneficiary the entire amount so collected or any part thereof may be released to Trustor. Such application or release shall not cure or waive any default or notice of default hereunder or invalidate any act done pursuant to such notice.
- (3) To appear in and defend any action or proceeding purporting to affect the security hereof or the rights or powers of Beneficiary or Trustee; and to pay all costs and expenses, including cost of evidence of title and attorney's fees in a reasonable sum, in any such action or proceeding in which Beneficiary or Trustee may appear, and in any suit brought by Beneficiary to foreclose this Deed.
- (4) To pay: at least ten days before delinquency all taxes and assessments affecting said property, including assessments on appurtenant water stock; when due, all incumbrances, charges and liens, with interest, on said property or any part thereof, which appear to be prior or superior hereto; all costs, fees and expenses of this Trust. Should Trustor fail to make any payment or to do any act as herein provided, then Beneficiary or Trustee, but without obligation so to do and without notice to or demand upon Trustor and without releasing Trustor from any obligation hereof, may: make or do the same in such manner and to such extent as either may deem necessary to protect the security hereof, Beneficiary or Trustee being authorized to enter upon said property for such purposes; appear in and defend any action or proceeding purporting to affect the security hereof or the rights or powers of Beneficiary or Trustee; pay, purchase, contest or compromise any incumbrance, charge or lien which in the judgment of either appears to be prior or superior hereto; and, in exercising any such powers, pay necessary expenses, employ counsel and pay his reasonable fees.
- (5) To pay immediately and without demand all sums so expended by Beneficiary or Trustee, with interest from date of expenditure at the amount allowed by law in effect at the date hereof, and to pay for any statement provided for by law in effect at the date hereof regarding the obligation secured hereby any amount demanded by the Beneficiary not to exceed the maximum allowed by law at the time when said statement is demanded.

INITIALS \_\_\_\_\_

(6) That any award of damages in connection with any condemnation for public use of or injury to said property or any part thereof is hereby assigned and shall be paid to Beneficiary who may apply or release such moneys received by him in the same manner and with the same effect as above provided for disposition of proceeds of fire or other insurance.

(7) That by accepting payment of any sum secured hereby after its due date, Beneficiary does not waive his right either to require prompt payment when due of all other sums so secured or to declare default for failure so to pay.

(8) That at any time or from time to time, without liability therefor and without notice, upon written request of Beneficiary and presentation of this Deed and said note for endorsement, and without affecting the personal liability of any person for payment of the indebtedness secured hereby, Trustee may: reconvey any part of said property; consent to the making of any map or plat thereof; join in granting any easement thereon; or join in any extension agreement or any agreement subordinating the lien or charge hereof.

(9) That upon written request of Beneficiary stating that all sums secured hereby have been paid, and upon surrender of this Deed and said note to Trustee for cancellation and retention and upon payment of its fees, Trustee shall reconvey, without warranty, the property then held hereunder. The recitals in such reconveyance of any matters or facts shall be conclusive proof of the truthfulness thereof. The Grantee in such reconveyance may be described as "the person or persons legally entitled thereto." Five years after issuance of such full reconveyance, Trustee may destroy said note and this Deed (unless directed in such request to retain them).

(10) That as additional security, Trustor hereby gives to and confers upon Beneficiary the right, power and authority, during the continuance of these Trusts, to collect the rents, issues and profits of said property, reserving unto Trustor the right, prior to any default by Trustor in payment of any indebtedness secured hereby or in performance of any agreement hereunder, to collect and retain such rents, issues and profits as they become due and payable. Upon any such default, Beneficiary may at any time without notice, either in person, by agent, or by a receiver to be appointed by a court, and without regard to the adequacy of any security for the indebtedness hereby secured, enter upon and take possession of said property or any part thereof, in his own name sue for or otherwise collect such, rents, issues, and profits, including those past due and unpaid, and apply the same, less costs and expenses of operation and collection, including reasonable attorney's fees, upon any indebtedness secured hereby, and in such order as Beneficiary may determine. The entering upon and taking possession of said property, the collection of such rents, issues and profits and the application thereof as aforesaid, shall not cure or waive any default or notice of default hereunder or invalidate any act done pursuant to such notice.

(11) *That upon default by Trustor in payment of any indebtedness secured hereby or in performance of any agreement hereunder, Beneficiary may declare all sums secured hereby immediately due and payable by delivery to Trustee of written declaration of default and demand for sale and of written notice of default and of election to cause to be sold said property, which notice Trustee shall cause to be filed for record. Beneficiary also shall deposit with Trustee this Deed, said note and all documents evidencing expenditures secured hereby.*

INITIALS \_\_\_\_\_

After the lapse of such time as may then be required by law following the recordation of said notice of default, and notice of sale having been given as then required by law, Trustee, without demand on Trustor, shall sell said property at the time and place fixed by it in said notice of sale, either as a whole or in separate parcels, and in such order as it may determine, at public auction to the highest bidder for cash of lawful money of the United States, payable at time of sale. Trustee may postpone sale of all or any portion of said property by public announcement at such time and place of sale, and from time to time thereafter may postpone such sale by public announcement at the time fixed by the proceeding postponement. Trustee shall deliver to such purchaser its deed conveying the property so sold, but without any covenant or warranty, express or implied. The recitals in such deed of any matters or facts shall be conclusive proof of the truthfulness thereof. Any person, including Trustor, Trustee, or Beneficiary as hereinafter defined, may purchase at such sale.

After deducting all costs, fees and expenses of Trustee and of this Trust, including cost of evidence of title in connection with sale, Trustee shall apply the proceeds of sale to payment of: all sums expended under the terms hereof, not then repaid, with accrued interest at the amount allowed by law in effect at the date hereof; all other sums then secured hereby; and the remainder, if any, to the person or persons legally entitled thereto.

(12) Beneficiary, or any successor in ownership of any indebtedness secured hereby, may from time to time, by instrument in writing, substitute a successor or successors to any Trustee named herein or acting hereunder, which instrument, executed by the Beneficiary and duly acknowledged and recorded in the office of the recorder of the county or counties where said property is situated, shall be conclusive proof of proper substitution of such successor Trustee or Trustees, who shall, without conveyance from the Trustee predecessor, succeed to all its title, estate, rights, powers and duties. Said instrument must contain the name of the original Trustor, Trustee and Beneficiary hereunder, the book and pages where this Deed is recorded and the name and address of the new Trustee.

(13) That this Deed applies to, inures to the benefit of, and binds all parties hereto, their heirs, legatees, devisees, administrators, executors, successors and assigns. The term Beneficiary shall mean the owner and holder, including pledgees, of the note secured hereby, whether or not named as Beneficiary herein. In this Deed, whenever the context so requires, the masculine gender includes the feminine and/or neuter, and the singular number includes the plural.

(14) That Trustee accepts this Trust when this Deed, duly executed and acknowledged, is made a public record as provided by law. Trustee is not obligated to notify any party hereto of pending sale under any other Deed of Trust or of any action or proceeding in which Trustor, Beneficiary or Trustee shall be a party unless brought by Trustee.

INITIALS \_\_\_\_\_

**REQUEST FOR FULL RECONVEYANCE**

TO: \_\_\_\_\_, TRUSTEE:

The undersigned is the legal owner and holder of all indebtedness secured by the within Deed of Trust. All sums secured by said Deed of Trust have been fully paid and satisfied; and you are hereby requested and directed, on payment to you of any sums owing to you under the terms of said Deed of Trust, to cancel all evidences of indebtedness, secured by said Deed of Trust, delivered to you herewith, together with the said Deed of Trust, and to reconvey, without warranty, to the parties designated by the terms of said Deed of Trust, all the estate now held by you under the same.

Dated: \_\_\_\_\_

\_\_\_\_\_  
By: \_\_\_\_\_ By: \_\_\_\_\_

Please mail Reconveyance to:

\_\_\_\_\_

Do not lose or destroy this Deed of Trust OR THE NOTE which it secures. Both original documents must be delivered to the Trustee for cancellation before reconveyance will be made.

STATE OF CALIFORNIA  
COUNTY OF SAN FRANCISCO

ON \_\_\_\_\_ before me, \_\_\_\_\_ personally appeared \_\_\_\_\_ proved to me on the basis of satisfactory evidence to be the person(s) whose name(s) is/are subscribed to the within instrument and acknowledged to me that he/she/they executed the same in his/her/their authorized capacity(ies), and that by his/her/their signature(s) on the instrument the person(s), or the entity upon behalf of which the person(s) acted, executed the instrument.

I certify under penalty of perjury under the laws of the State of California that the foregoing paragraph is true and correct.

WITNESS my hand and official seal.

Signature \_\_\_\_\_

Free Recording Requested Pursuant to  
Government Code Section 27383

When recorded, mail to:  
Mayor's Office of Housing as Successor Agency to  
the San Francisco Redevelopment Agency  
1 South Van Ness Avenue, 5<sup>th</sup> Floor  
San Francisco, California 94103  
Attn: Gwen Sebay, Housing Division

----- Space Above This Line for Recorder's Use -----

1345 Turk Street, Unit #000  
Assessor's Block 756, Lot 000

**ADDENDUM TO DEED OF TRUST**

THIS ADDENDUM TO DEED OF TRUST ("Addendum") is part of the Deed of Trust and Assignment of Rents dated \_\_\_\_\_, **2012** ("Deed of Trust"), to which it is attached, on \_\_\_\_\_, **2012**, between **Buyer, Vested Title** ("Trustor" or "Owner"), whose address is **1345 Turk Street, Unit #xxx, San Francisco, California 94115**, and **First American Title Company**, a corporation ("Trustee"), and the City and County of San Francisco, a municipal corporation, acting through the Mayor's Office of Housing, as successor to the Redevelopment Agency of the City and County of San Francisco (the "City"), a public body, corporate and politic, whose address is 1 South Van Ness Avenue, 5<sup>th</sup> Floor, San Francisco, California 94103 ("City" or "Beneficiary"). The following provisions are made a part of the Deed of Trust:

Owner obtained a loan ("Senior Lien") from **Lender Name** ("Senior Lender"), which Loan is secured by a first deed of trust lien on the Property ("First Deed of Trust").

Owner and City executed a Declaration of Resale Restrictions and Option to Purchase Agreement, dated the same date as the Deed of Trust ("Declaration"). The Declaration establishes, in part, the rights and obligations of Owner and the City in the event of a Transfer of the Property. "Transfer" means any voluntary or involuntary sale, assignment or transfer of any interest in the Property.

Owner and the City also executed a Promissory Note, dated the same date as the Deed of Trust and this Addendum to Deed of Trust, which is secured by the Deed of Trust ("City Note").

Capitalized terms used herein and not defined shall have the meanings set forth in the Declaration.

COVENANTS. Owner and the City covenant and agree as follows:

- 1. Prior Deeds of Trust; Charges; Liens.** Owner shall perform all of Owner's obligations under the First Deed of Trust and other Deeds of Trust, including Owner's covenants to make payments when due. Owner shall pay on time and directly to the person owed payment all taxes, assessments, charges, fines and impositions attributable to the Property which may attain priority over this Deed of Trust.

Except for the Senior Liens, Owner shall promptly discharge any other lien which shall have attained priority over this Deed of Trust unless Owner: (a) contests in good faith the lien by, or defends against enforcement of the lien in, legal proceedings which, in the City's sole discretion, operate to prevent the enforcement of the lien; or (b) obtains from the holder of the lien an agreement satisfactory to the City in its sole discretion subordinating the lien to this Deed of Trust. Except for the Senior Lien, if the City determines that any part of the Property is subject to a lien which may attain priority over this Deed of Trust, the City may give Owner a notice identifying the lien. Owner shall satisfy such lien or take one or more of the actions set forth above within ten (10) days of the giving of notice.

- 2. Obligations Cancelled.** Upon a Transfer of the Property in accordance with the Declaration, Owner's obligations hereunder shall be cancelled, and the lien of this Deed of Trust shall be reconveyed.
- 3. Sale of Note.** The City Note or a partial interest in the City Note (together with this Deed of Trust) may be sold one or more times without prior notice to Owner. If the City Note is sold, Owner will be given written notice of the sale in accordance with and containing any other information required by applicable law.

BY SIGNING BELOW, the Owner accepts and agrees to the terms and covenants contained in this Deed of Trust.

\_\_\_\_\_  
**Buyer Name**

\_\_\_\_\_  
**Buyer Name**

----- Space Below This Line for Acknowledgment -----

## PROMISSORY NOTE SECURED BY DEED OF TRUST

\_\_\_\_\_, 2012

San Francisco, California

### THIS NOTE MAY NOT BE PREPAID

FOR VALUE RECEIVED, the undersigned **Buyer Name, Vested Title** (“Debtor”), promises to pay to the City and County of San Francisco, a municipal corporation, acting through the Mayor’s Office of Housing, as successor to the Redevelopment Agency of the City and County of San Francisco (the “City”), a public body, corporate and politic, of the State of California, (“Holder” or “City”), at 1 South Van Ness Avenue, 5th Floor, San Francisco, California 94103, or any other place designated in writing by Holder to Debtor, the amount calculated under the formula stated in this Promissory Note (“Note”).

Debtor and Holder executed a Declaration of Resale Restrictions and Option to Purchase Agreement (“Declaration”), dated the same date as this Note, which, in part, establishes the rights and obligations of the Debtor and Holder in the event Debtor desires to Transfer the real property described in the Declaration (the “Property”). “Transfer” means any voluntary or involuntary sale, assignment or transfer of any interest in the Property.

Debtor obtained a loan (“Senior Lien”) from **Lender Name** (“Senior Lender”), which loan is secured by a first deed of trust lien on the Property (“First Deed of Trust”). The Declaration and this Promissory Note are subordinate to the Senior Lien.

This Note is secured by a Second Deed of Trust, dated the same date as this Note, executed by Debtor in favor of Holder, with **Old Republic Title Company** as Trustee, which secures the payment of the debt evidenced by this Note, and all renewals, extensions and modifications of the Note (“City’s Deed of Trust”).

Capitalized terms used herein and not defined shall have the meanings set forth in the Declaration or in City’s Deed of Trust, as applicable.

Upon Debtor’s actual, attempted or pending Transfer of the Property other than as permitted under the Declaration, or upon default under the Senior Lien (the “Trigger Date”), Debtor shall pay to Holder:

- a. The difference between (1) the Fair Market Value of the Property as of the Trigger Date and (2) the Resale Affordable Purchase Price as of the Trigger Date, had such Transfer been executed in accordance with the Declaration. Fair Market Value shall be determined by an appraisal of the Property. The appraiser shall be an independent, MAI-certified appraiser who has experience in residential appraisals in San Francisco, and shall be selected by Holder; plus

- b. Any amounts disbursed by Holder under Section 5 of the Deed of Trust to protect Holder's rights in the real property described in the Declaration and Deed of Trust; plus
- c. Commencing from the Trigger Date, interest on the amounts due at an annual rate of 10%, compounded.

With or without the filing of any legal action, proceeding or appeal, or appearance in any bankruptcy proceeding, Debtor agrees to pay on demand, together with interest at the above rate from the date of such demand until paid, all reasonable attorneys' fees, costs of collection, costs, and expenses incurred by Holder in connection with the defense or enforcement of this Note and the Deed of Trust.

No previous waiver and no failure or forbearance by Holder in acting with respect to the terms of this Note or the Deed of Trust shall constitute a waiver of any breach, default, or failure of condition under this Note, the Deed of Trust, or the Declaration. A waiver of any term of this Note, the Deed of Trust, or the Declaration must be made in writing, signed by both parties, and shall be limited to the express written terms of such waiver. In the event of any inconsistencies between the terms of this Note and the terms of any other document related to the debt evidenced by this Note, the terms of this Note shall prevail.

If this Note is executed by more than one person as Debtor, the obligations of each such person shall be joint and several, and each shall be primarily and directly liable hereunder. Debtor waives presentment, demand, notice of dishonor, notice of default or delinquency, notice of acceleration, notice of protest and nonpayment, notice of costs, expenses or losses and interest thereon, notice of interest on interest and late charges, and diligence in taking any action to collect any sums owing under this Note or in proceeding against any of the rights or interest in or to properties securing payment of this Note.

Time is of the essence with respect to every provision in this Note. This Note shall be construed and enforced in accordance with the substantive and procedural laws of the State of California, except to the extent that Federal laws preempt the laws of the State of California, and all persons and entities in any manner obligated under this Note consent to the jurisdiction of any Federal or State Court within the State of California having proper venue and also consent to service of process by any means authorized by California or Federal law.

This Note shall be cancelled upon Debtor's Transfer of the Property in accordance with the Declaration.

---

**Buyer Name**

---

**Buyer Name**

Free Recording Pursuant to  
Government Code Section 27383 at  
the Request of the Mayor's Office of  
Housing of the City and County of San  
Francisco

WHEN RECORDED MAIL TO:  
MAYOR'S OFFICE OF HOUSING  
AS SUCCESSOR AGENCY TO THE  
SAN FRANCISCO  
REDEVELOPMENT AGENCY  
1 SO. VAN NESS AVE, 5<sup>th</sup> FLOOR  
SAN FRANCISCO, CA 94103  
ATTN: Housing Division

1345 Turk Street, Unit #000  
Block 756, Lot 000

SPACE ABOVE THIS LINE RESERVED APN:  
FOR RECORDER'S USE

**NOTICE OF AFFORDABILITY RESTRICTIONS ON TRANSFER OF  
PROPERTY  
(Owner-Occupied Home)**

**NOTICE IS HEREBY GIVEN**, that the City and County of San Francisco, a municipal corporation, acting through the Mayor's Office of Housing, as successor to the Redevelopment Agency of the City and County of San Francisco (the "City") to carry out certain obligations under the Community Redevelopment Law of the State of California (Health and Safety Code Section 33000 et seq.) and the Redevelopment Plan for the **Former Western Addition Redevelopment Project Area**, has required **Buyer(s)/Vested Title**, ("Owners") to enter into certain affordability covenants and restrictions entitled, Limited Equity Home Ownership Program Declaration of Restrictions for For-Sale Affordable Housing Units and Option to Purchase Agreement (the "Restrictions"), with reference to certain real property (the "Property"), located at **1345 Turk Street, Unit #000**, in the City and County of San Francisco, Assessor's Parcel No. **756, Lot 000**, and further described in Exhibit "A", incorporated herein by reference.

The affordability covenants and restrictions contained in the Restrictions include without limitation and as further described in the Restrictions:

1. The affordability restrictions will expire 45 (forty-five) years from the date of recordation.
2. **1345 Turk Street, Unit #000, San Francisco, California 94115.**
3. **Assessor's Block 756, Lot 000.** The land referred to is situated in the County of San Francisco, City of San Francisco, State of California, and further described in Exhibit "A", incorporated herein by reference.
4. The affordability covenants or restrictions include the following:
  - (a) Affordability of this unit is restricted to **00.00%** of Area Median Income;
  - (b) Unit is designated for homeownership only and cannot be rented by Owners;
  - (c) Unit is to remain owner-occupied by the Owners;
  - (d) Restrictions on refinancing include the following:
    - 1) Owners can refinance up to the original value of their first mortgage in order to obtain a lower interest or withdraw principal paid down on their mortgage;
    - 2) Owners may also refinance to withdraw up to 50% of the difference between the resale affordable purchase price and their original affordable purchase price, for the following reasons only:
      - i) To make capital improvements to the home;
      - ii) To pay for post-secondary education expenses of a house hold member
      - iii) To meet the cost of an owner's or owner's immediate family member's catastrophic illness;
      - iv) To secure funds required to implement a marriage dissolution agreement or domestic partnership dissolution agreement.
  - (e) Requirements at Resale: Owners may only transfer their homes to other Eligible Buyers or to the City. Though each owner bears sole responsibility for finding an Eligible Buyer if s/he seeks to sell his/her unit, the City will attempt to assist owners in locating Eligible buyers, whether through a mailing to interested persons, accessing a waiting list, or conducting a lottery. Once an owner identifies a potential buyer for his/her unit, only the City can certify that the buyer is actually an Eligible Buyer

(f) Notice is being recorded for notice only, and that the affordability covenants prevail if there is any conflict between the Notice and the recorded covenants.

5. The affordability covenants and Notice are being recorded concurrently.

This Notice of Affordability Restrictions on Transfer of Property (the "Notice") is recorded for the purpose of providing notice only, and it in no way modifies the provisions of the Restrictions. In the event of any conflict between this Notice and the Restrictions, the terms of the Restrictions shall prevail.

The Restrictions have been recorded on \_\_\_\_\_, 2012, as Document/Instrument No. \_\_\_\_\_, and shall remain in effect until \_\_\_\_\_, 2057 [Date of expiration of Restrictions].

This Notice is being recorded and filed by the City in compliance with Health and Safety Code Sections 33334.3 and/or Section 33413, as amended effective this date, and shall be indexed against the City and the Owner.

IN WITNESS WHEREOF, the parties have executed this Notice of Affordability Restrictions on Transfer of Property on or as of the date first written above.

Mayor's Office of Housing of the  
City and County of San Francisco,  
a public body, corporate and politic

OWNER:

By: \_\_\_\_\_  
Olson Lee, Director

\_\_\_\_\_  
Buyer

\_\_\_\_\_  
Buyer

Free Recording Pursuant to  
Government Code Section 27383 at the  
Request of the Mayor's Office of Housing  
of the City and County of San Francisco

WHEN RECORDED, PLEASE MAIL THIS  
INSTRUMENT TO:

Mayor's Office of Housing as successor to San  
Francisco Redevelopment Agency  
of the City and County of San Francisco  
1 South Van Ness Avenue, 5<sup>th</sup> Floor  
San Francisco, CA 94103

1345 Turk Street, Unit #000  
Assessor's Block 756, Lot 000

SPACE ABOVE THIS LINE RESERVED FOR RECORDER'S USE

## Request For Notice Under Section 2924b Civil Code

In accordance with Section 2924b, Civil Code, request is hereby made that a copy of any Notice of Default and a copy of any Notice of Sale under the Deed of Trust recorded as instrument No. \_\_\_\_\_ on \_\_\_\_\_, 2012, in Book \_\_\_\_\_ Page \_\_\_\_\_, Official Records of the City and County of San Francisco, California, and describe land therein as Exhibit A (attached).

Executed by Buyer(s) Vested Title, as Trustor, in which Lender Name is named as Beneficiary, and \_\_\_\_\_ as Trustee, be mailed to the Mayor's Office of Housing as Successor to the San Francisco Redevelopment Agency at 1 South Van Ness Avenue, 5<sup>th</sup> Floor, San Francisco, CA 94103.

Mayor's Office of Housing, of the  
City and County of San Francisco, a  
public body, corporate and politic

By: \_\_\_\_\_  
Olson Lee, Director

Date: \_\_\_\_\_

CONSENT AND SUBORDINATION

The undersigned, City and County of San Francisco, a municipal corporation, as successor agency to the Redevelopment Agency of the City and County of San Francisco, which is the Beneficiary under that certain Deed of Trust recorded on April 22, 2010, under Recorder's Serial Number 2010-I955755, in Reel K129, Image 0009 in Official Records of the County Recorder of the County of San Francisco, executed by MSPDI Turk, LLC, a California limited liability company, as Trustor, with Old Republic Title Company, as Trustee, does hereby consent to the execution and recordation of the attached Declaration of Conditions, Covenants and Restrictions and does hereby subordinate said Deed of Trust to said Declaration of Conditions, Covenants and Restrictions to the same extent and with the same force and effect as if said Declaration of Conditions, Covenants and Restrictions had been executed and recorded prior to the execution and recordation of said Deed of Trust.

IN WITNESS WHEREOF, the undersigned has executed this Consent and Subordination this 9th day of APRIL, 2012.

DATED: 9 APRIL 2012

City and County of San Francisco, a municipal corporation, acting by and through the Mayor's Office of Housing, Beneficiary

BY:   
Olson Lee  
Executive Director

APPROVED AS TO FORM:  
DENNIS J. HERRERA, City Attorney

By:   
Evan Gross  
Deputy City Attorney

(PLEASE ATTACH NOTARY ACKNOWLEDGEMENT HERETO)

State of California  
County of San Francisco

On April 9 2012 before me, Eugene T. Flannery, Notary Public, personally appeared Olson Lee, who proved to me on the basis of satisfactory evidence to be the person whose name is subscribed to the within instrument and acknowledged to me that he executed the same in his authorized capacity, and that by his signature on the instrument the person, or the entity upon behalf of which the person acted, executed the instrument.

I certify under PENALTY OF PERJURY under the laws of the State of California that the foregoing paragraph is true and correct.

WITNESS my hand and official seal.

Signature Eugene T. Flannery



CONSENT AND SUBORDINATION

The undersigned, Wells Fargo Bank, National Association, as Beneficiary, under that certain Deed of Trust recorded on October 28, 2010, under Recorder's Serial Number 2010-J071571, in Official Records of the County Recorder of the County of San Francisco, executed by MSPDI Turk, LLC, a California limited liability company, as Trustor, with American Securities Company, a California Corporation, as Trustee, does hereby consent to the execution and recordation of the attached Declaration of Conditions, Covenants and Restrictions and does hereby subordinate said Deed of Trust to said Declaration of Conditions, Covenants and Restrictions to the same extent and with the same force and effect as if said Declaration of Conditions, Covenants and Restrictions had been executed and recorded prior to the execution and recordation of said Deed of Trust.

IN WITNESS WHEREOF, the undersigned has executed this Consent and Subordination this 27<sup>th</sup> day of February, 2012.

DATED: 2/27/12

Wells Fargo Bank, National Association

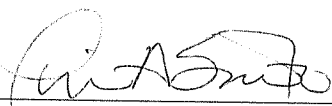
BY:   
Lori A. Saito  
Vice President

BY: \_\_\_\_\_

(PLEASE ATTACH NOTARY ACKNOWLEDGEMENT HERETO)

# ACKNOWLEDGMENT

State of California        }  
  }ss.  
County of San Francisco }

On February 27, 2012, before me, June L. Errington, a Notary Public, personally appeared Lori A. Saito who proved to me on the basis of satisfactory evidence to be the person whose name is subscribed to the within instrument and acknowledged to me that she executed the same in her authorized capacity, and that by her signature on the instrument the person, or the entity upon behalf of which the person acted, executed the instrument.

I certify under PENALTY OF PERJURY under the laws of the State of California that the foregoing paragraph is true and correct

WITNESS my hand and official seal.

Signature June L. Errington (Seal)

